

**Hazardous Areas Technical Guide**  
**Explosion Protection Terminology & Regulations**  
**Introduction**  
Let's connect.



# **You are looking for a partner that you can depend on**

## **We are your experts for the best connections in Industrial Connectivity**

Weidmüller – our name has been synonymous with power, competence and reliability in machine construction, the process industry, device manufacture, the energy sector and traffic engineering for more than 160 years. In more than 80 countries, we support both our customers and our partners by supplying innovative solutions and services, as well as cutting a convincing figure as a partner that you can depend on.

Global competition demands plants with the maximum level of automation and availability combined with minimum maintenance and repair outlay. Security is hereby a key competitive factor and one with utmost priority. Other key factors include a long service life and the lowest possible power consumption – combined of course with compliance with highest environmental standards and requirements. More complex plants and rapidly changing technologies place highest demands on the signal inversion and signal transmission, the connection system and the power management.

With Weidmüller as your long-standing and experienced process industry partner, you can be sure of: Application-specific solutions engineered and designed to the highest standards in which investment protection and process reliability are crucial for the safe operation of the any plant. Secure power, signal and data transmission for maximum plant availability and efficiency in the system. Support in complying with environmental and safety standards, as well as power management.

All this makes us your competence partner for networked solutions in the panel and process technology, as well as for the safe and efficient operation of process plants.

As an industrial connectivity partner, we support you in all your connectivity requirements, from the cabinet to the field. To create valuable innovations, we require deep insights into the needs of people who have to master industrial connectivity tasks in machinery, energy generation, process production, transportation, the development of infrastructures and even device manufacturing on a daily basis. What would bring them a significant benefit? What specific challenges do their industries face? We ask ourselves these questions and respond with strong product solutions, tailored to each industry.



This publication provides a brief overview of the essential aspects of explosion protection. Ultimately, safety in a potentially explosive atmosphere is a team effort. Manufacturers have a responsibility to ensure only safe equipment is placed on the market. Installers must follow the instructions provided and use the equipment only for its intended purpose. Finally, the user has a duty to inspect and maintain the equipment in a safe working order. The directives and national and international standards provide a basis for a safer future.

# The Weidmüller range at a glance

## A world full of connections



Cloud Services



Field Services

### Applications



Photovoltaics



Wind



Weidmüller Monitoring Systems



Machinery

### Devices



Electronic housings



PCB RJ 45 sockets



PCB USB sockets



PCB power connectors  
PUSH IN



PCB power connectors  
screw



PCB power terminals  
PUSH IN



PCB power terminals  
screw



PCB signal connectors  
PUSH IN



PCB signal connectors  
screw



PCB signal terminals  
PUSH IN



PCB signal terminals  
screw

### Cabinet



Wireless routers



Routers



IoT gateways



IoT controllers with  
web-based engineering



Multi-touch panels



Communicative signal  
processing



Remote I/O



Switches unmanaged



Switches managed



Cable connectors



Communication-capable  
power supply



Service interfaces



Energy monitoring



Analogue signal conditioning



Solid-state relays



Power supplies



Buffer/UPS/Batteries



Control voltage distribution



Safety relays



Surge protection signals



Terminals stud



Terminals screw



Terminals tension clamp



Terminals PUSH IN



Shielding and earthing



Interfaces



Surge protection power



Relay modules



Relays and solid-state relays

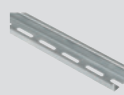

Mounting rails



Assembled rails



Cable ducts



Filter fans

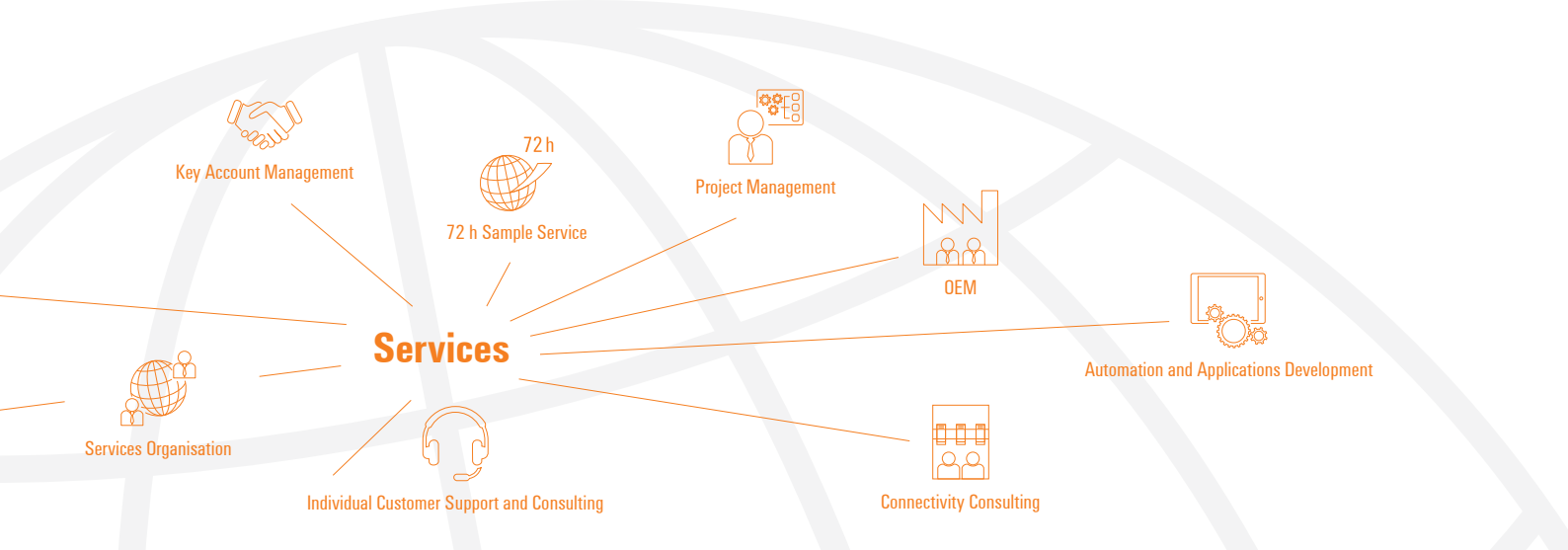

Remote Maintenance



Terminal Strip Assembly



Enclosure Assembly



Industrial Analytics

## Field



IE connections



Unmanaged switches IP67



Contactless power transmission



SAI remote I/O



SAI passive



SAI interfaces



Decentralised power bus systems



Heavy-duty connectors



HighPower connectors



IE interfaces



Cord sets



Cable entry systems



Stainless steel enclosures



Aluminium enclosures



Plastic enclosures



Cable glands

## Workplace



Weidmüller Configurator



Systemised marking software



Printers (ink application)



Printers (thermal transfer)



Wire markers



Cable markers



Terminal markers



Device markers



Testing



Other tools



Cutting



Stripping



Crimping



Machines

# Contents

<b>Introduction</b>	<b>10</b>
<b>Directives, Standards and Regulations</b>	<b>11</b>
2.1 EU-Directives	11
2.1.1 Directive 2014/34/EU	11
2.1.1.1 Scope and general definitions	11
2.1.1.2 Groups and categories of apparatus	12
2.1.1.3 CE Mark	13
2.1.1.4 Other Directives that may be applicable	14
2.1.1.5 Marking	14
2.1.1.6 Instructions	15
2.1.2 Directive 1999/92/EC	16
2.1.2.1 Scope	16
2.1.2.2 Requirements	16
2.1.2.3 Selection of equipment and protective systems	17
2.2 North America	17
2.3 International IECEx Scheme	17
2.3.1 IECEx Scheme Objective	17
2.3.2 IECEx International Certification Scheme	17
2.3.2.1 The IECEx Certified Equipment Program provides both	18
2.3.2.2 The IECEx Certified Service Facilities Program	18
2.3.2.3 IECEx Certification of Personnel Competencies (CoPC)	18
<b>Basic Principles of Explosive Atmospheres</b>	<b>19</b>
3.1 Explosive atmosphere	19
3.2 Ignition sources	19
3.3 The Hazard Triangle	20
<b>Gases and Vapours</b>	<b>21</b>
4.1 Characteristics of gases and vapours	21
4.1.1 Principles	21
4.1.1.1 Flash point	21
4.1.1.2 Ignition temperature	21
4.1.1.3 Explosion Limits	21
4.1.1.4 Maximum oxygen concentration	22
4.1.1.5 Vapour density	22
4.1.1.6 Ignition requirements/minimum ignition energy	22
4.1.1.7 Maximum Experimental Safe Gap (MESG)	22
4.1.2 Explosion Group	22
4.1.3 Temperature classification	23
4.2 Area classification	24
4.2.1 General	24
4.2.2 Definitions of zones	24
4.2.2.1 Zone 0	24
4.2.2.2 Zone 1	24
4.2.2.3 Zone 2	25
4.2.2.4 Examples of zone identification	25
4.2.3 Sources of release	26
4.2.3.1 Grades of release	26
4.2.3.2 Extent of zone	27
4.2.3.3 Ventilation	27
4.2.4 Equipment protection level (EPL)	28
4.3 Gas explosion protection concepts for electrical equipment	29
4.3.1 Zones of use	29
4.3.2 Protection concepts	29
4.3.2.1 Increased Safety 'e'	29
4.3.2.2 Flameproof 'd'	33

4.3.2.3.....	Intrinsic Safety ‘i’ .....	36
4.3.2.4.....	Pressurisation ‘p’ .....	42
4.3.2.5.....	Equipment protection level (EPL) Ga / zone 0 equipment.....	42
4.3.2.6.....	Equipment protection level (EPL) Gc / zone 2 equipment.....	44
4.3.2.7.....	Powder Filling ‘q’ .....	44
4.3.2.8.....	Oil Immersion ‘o’ .....	45
4.3.2.9.....	Encapsulation ‘m’ .....	45
4.4.....	Installation .....	45
4.4.1.....	Selection of equipment.....	45
4.4.2.....	Protection against dangerous incendive sparking .....	46
4.4.3.....	Electrical protection .....	47
4.4.4.....	Wiring systems.....	47
4.4.5.....	Additional requirements for flameproof enclosures ‘d’ .....	48
4.4.6.....	Additional requirements for Increased Safety ‘e’ .....	49
4.5.....	Inspection and Maintenance .....	49
4.5.1.....	General requirements .....	49
4.5.1.1.....	Documentation .....	50
4.5.1.2.....	Qualification of personnel .....	50
4.5.1.3.....	Permit-to-workl .....	50
4.5.2.....	Inspectionsl.....	50
4.5.2.1.....	General.....	50
4.5.2.2.....	Types of inspection .....	51
4.5.2.3.....	Grades of inspection.....	51
4.5.3.....	Regular periodic inspections .....	51
4.5.4.....	Continuous supervision by skilled personnel .....	51
4.5.5.....	Maintenance.....	52
4.5.6.....	Repair.....	52
<b>5.....</b>	<b>Combustible dusts.....</b>	<b>53</b>
5.1.....	Definitions and Dust characteristics.....	53
5.1.1.....	General.....	53
5.1.2.....	Dust definitions.....	53
5.1.2.1.....	Dust.....	53
5.1.2.2.....	Combustible dust .....	54
5.1.2.3.....	Conductive dust.....	54
5.1.2.4.....	Non-Conductive dust.....	54
5.1.2.5.....	Combustible flyings .....	54
5.1.2.6.....	EPL Da.....	54
5.1.2.7.....	EPL Db.....	54
5.1.2.8.....	EPL Dc.....	54
5.1.2.9.....	Explosive dust atmosphere .....	54
5.1.3.....	Dust characteristics.....	54
5.2.....	Area classification .....	55
5.2.1.....	Definitions of zones .....	55
5.2.1.1.1.....	Definition of zone 20.....	56
5.2.1.1.2.....	Examples of typical zone 20 locations.....	56
5.2.1.2.....	Zone 21 .....	56
5.2.1.2.1.....	Definition of zone 21 .....	56
5.2.1.2.2.....	Examples of typical zone 21 locations.....	56
5.2.1.3.....	Zone 22 .....	56
5.2.1.3.1.....	Definition of zone 22 .....	56
5.2.1.3.2.....	Examples of typical zone 22 locations.....	56
5.2.1.4.....	Zone identification .....	57
5.2.2.....	Grades of release, Extent of zones, Housekeeping .....	57
5.2.2.1.....	Grades of release.....	57
5.2.2.2.....	Extent of zones.....	58
5.2.2.3.....	Housekeeping.....	58

5.2.2.4	Removal of dust deposits	58
5.3	Dust explosion protection measures	59
5.3.1	Protective systems	59
5.3.1.1	Explosion resistant (containment)	59
5.3.1.2	Venting system	59
5.3.1.3	Suppression system	59
5.3.1.4	Isolation system	60
5.3.2	Protection by enclosures – t	60
5.3.3	Other protection concepts	61
5.3.7	Selection of apparatus	61
5.4	Installations	63
5.4.1	Types of cables	63
5.4.2	Cable installation	63
5.4.3	Cable entry devices	63
5.5	Inspection and maintenance	63
5.5.1	Inspection	63
5.5.2	Maintenance	64
5.5.3	Repair	64
<b>Explosion Protection in North America</b>		<b>65</b>
6.1	Overview of Regulations in North America (USA and Canada)	65
6.1.1	USA: the National Electrical Code (NEC)	65
6.1.2	Canada: the Canadian Electrical Code (CEC)	66
6.2	Class I, II, and III Hazardous Locations	66
6.2.1	Class I Locations	66
6.2.1.1	Class I, Division 1 Locations	66
6.2.1.2	Class I, Division 2 Locations	66
6.2.2	Class II Locations	67
6.2.2.1	Class II, Division 1 Locations	67
6.2.2.2	Class II, Division 2 Locations	67
6.2.3	Class III Locations	67
6.2.3.1	Class III, Division 1 Locations	67
6.2.3.2	Class III, Division 2 Locations	67
6.3	Protection Techniques	67
6.3.1	Protection Techniques under Class-Division	68
6.3.2	Enclosure Types to IP Designations	68
6.4	Equipment	68
6.4.1	Material Groups for Class-Division	68
6.4.2	Temperature Ratings for Class-Division	69
6.4.3	Equipment Marking	69
6.4.3.1	Equipment Marking for Class-Division	69
6.4.3.2	Equipment Marking for Class-Zone	69
6.4.3.2.1	Example Markings for Division-Based Zone Certification	70
6.4.3.2.2	Example Markings for IEC-based Zone certification	70
<b>Appendices</b>		<b>71</b>
Appendix I	Definitions and Abbreviations	72
Appendix II	Ingress and Impact protection for enclosures	76
Appendix III	Terminal Content using the 'Defined Arrangement Method'	77
Appendix IV	Inspection schedules for gas atmospheres	80
Appendix V	Inspection schedules for dust atmospheres	84
Appendix VI	Environmental Type designations for enclosures	87
Appendix VII	Certifications	88



# Section 1

## Introduction

Weidmüller is a leading international provider of solutions for electrical connectivity, transmission and conditioning of power, signal and data in industrial environments. The company with headquarters in Detmold / Germany develops, produces and sells products in the field of electrical connectivity and electronics all over the world.

Within the European Union we offer products designed and manufactured to the European standards for Electrical Apparatus for Potentially Explosive Atmospheres, the new ATEX directive, which has been in use since 1996 and has been mandatory throughout the EU since July 2003 and updated in 2014. The update became valid at 23.04.2016.

Weidmüller offers the most comprehensive range of ATEX certified enclosures, rail mounted terminals and accessories. Outside the European area, which is not controlled by the ATEX directive, our products are in line with the IECEx scheme. IECEx will have a growing importance for the future as a leading standard all over the world and the national standards follow the IECEx rules more and more. For other local installation requirements for hazardous areas we offer the relevant approvals based on the related local standards.

In addition to our leading manufacturing competence in the precision mechanics sector we offer a market and customer orientated portfolio of products for our target groups in industrial and process technology as well as transportation engineering.

This publication provides a brief overview of the essential aspects of explosion protection. Ultimately, safety in a potentially explosive atmosphere is a team effort. Manufacturers have a responsibility to ensure only safe equipment is placed on the market. Installers must follow the instructions provided and use the equipment only for its intended purpose. Finally, the user has a duty to inspect and maintain the equipment in a safe working order. The directives, and national and international standards provide a basis for a safer future.

## Section 2

### Directives, Standards and Regulations

#### 2.1

##### EU-Directives

Free movement of goods is a cornerstone of the common market. The mechanisms in place to achieve this aim are based on prevention of new barriers to trade, mutual recognition and technical harmonisation.

The New Approach to product regulation and the Global Approach to conformity assessment take place.

The “New Approach” directives are based on the following principles:

- Harmonisation is limited to Essential Health and Safety Requirements (EHSR)
- Only products fulfilling the EHSR may be placed on the market and put into service
- Harmonised standards which are transposed into national standards, are presumed to conform to the corresponding EHSR
- Application of harmonised standards or other technical specifications remains voluntary, and manufacturers are free to choose any technical solution that provides compliance with the EHSR
- Manufacturers may choose between different conformity assessment procedures provided for in the applicable directive

Equipment that complies with the new Directives may carry the CE mark. The CE mark together with the related EC Declaration of Conformity is like a passport to the common market.

Different requirements apply for Components than to Equipment. The CE marking is not applied to a Component, and there is a different document of conformity which has to be made and supplied, called an Attestation of Conformity.

The two Directives concerned with hazardous areas are called the ATEX Directive’s. ATEX is an abbreviation from the French ‘Atmosphères Explosibles’.

#### 2.1.1

##### Directive 2014/34/EU

Directive 2014/34/EU on the approximation of the laws of the Member States concerning equipment and protective systems intended for use in potentially explosive atmospheres

Equipment, protective systems, and the devices to which this Directive applies must meet the essential health and safety requirements set out in Annex II of the directive which apply to them, account being taken of their intended use.

#### 2.1.1.1

##### Scope and general definitions

Directive 2014/34/EU formerly known as Directive 94/9EC, is aimed at manufacturers. It applies to equipment and protective devices intended for use in potentially explosive atmospheres. Safety and controlling devices for use outside the hazardous area but essential for the safe operating of equipment inside it are also covered. The Directive applies to electrical as well as mechanical equipment and applies to gases, vapours, mists and dust atmospheres.

**‘Equipment’** means machines, apparatus, fixed or mobile devices, control components and instrumentation thereof and detection or prevention systems which, separately or jointly, are intended for the generation, transfer, storage, measurement, control and conversion of energy for the processing of material and which are capable of causing an explosion through their own potential sources of ignition.

**‘Protective systems’** means devices other than components of the equipment defined above which are intended to halt incipient explosions immediately and/or to limit the effective range of an explosion and which are separately placed on the market for use as autonomous systems.

**‘Components’** means any item essential to the safe functioning of equipment and protective systems but with no autonomous function.

**‘Safety devices, controlling devices and regulating devices’** means devices intended for use outside potentially explosive atmospheres but required for or contributing to the safe functioning of equipment and protective systems with respect to the risks of explosion.

**‘Assembly’** means a combination of two or more pieces of equipment, together with components if necessary, and placed on the market and/or put into service as a single functional unit. Assemblies can be placed on the market in different ways.

- Assemblies with a fully specified configuration of parts are put together and placed on the market as a single functional unit by the manufacturer of the assembly. The manufacturer assumes responsibility for compliance of the integral assembly with the Directive and must therefore provide clear instructions for assembly/installation/operation/maintenance etc. The EU declaration of conformity as well as the instructions for use must refer to the assembly as a whole. It must be clear which is/are the combination(s) that form(s) the assemblies.
- Assemblies forming a modular system. In this case the parts are not necessarily put together by the manufacturer of the assembly, and placed on the market as a single functional unit. The manufacturer is responsible for the compliance of the assembly with the Directive as long as the parts are chosen from the defined range and selected and combined according to his instructions.

**‘Installation’** means a combination of two or more pieces of equipment, which were already placed on the market independently by one or more manufacturers. Installing and combining the equipment on the user’s premises is not considered manufacturing and therefore the resulting installation is outside the scope of the ATEX Directive but will be subject to the legal requirements applicable such as Directive 1999/92/EC.

Explosive atmospheres is a mixture with air, under atmospheric conditions, of flammable substances in the form of gases, vapours, mists or dusts in which, after ignition has occurred, combustion spreads to the entire unburned mixture.

The Directive does not cover the following applications:

- Medical devices intended for use in a medical environment
- Equipment and protective systems where the explosion hazard results exclusively from the presence of explosive substances or unstable chemical substances
- Equipment intended for use in domestic and non-commercial environments where potentially explosive atmospheres may only rarely be created, solely as a result of the accidental leakage of fuel gas
- Personal protective equipment covered by Directive 89/686/EEC is repealed with effect from 21 April 2018 by "Regulation (EU) 2016/425 (1)
- Seagoing vessels and mobile offshore units together with equipment on board such vessels or units. FPSO’s are not considered mobile offshore units.
- Means of transport, i.e. vehicles and their trailers intended solely for transporting passengers by air or by road, rail or water networks, as well as means of transport in so far as such means are designed for transporting goods by air, by public road or rail networks or by water. Vehicles intended for use in a potentially explosive atmosphere shall not be excluded
- Arms, munitions and war material. Dual-purpose equipment is not excluded.

## 2.1.1.2

### Groups and categories of apparatus

Apparatus are divided into equipment groups and categories:

Equipment group I applies to equipment intended for use in underground parts of mines, and in those parts of surface installations of such mines, liable to be endangered by firedamp and/or combustible dust. Equipment Group I is further subdivided into categories M1 and M2.

Equipment group II applies to equipment intended for use in other places liable to be endangered by explosive atmospheres. Equipment Group II is subdivided into categories 1, 2 and 3.

The equipment selection is shown in table 1.

Table 1: **Equipment Selection (ATEX)**

	Category of equipment	Level of protection	Performance of protection	Conditions of operation
<b>Apparatus Group I (Mines)</b>	M1	Very high	Two independent means of protection or safe even when two faults occur independently of each other.	Equipment remains energised and functioning when explosive atmosphere present
	M2	High	Suitable for normal operation and severe operating conditions. If applicable also suitable for frequently occurring disturbances or for faults which are normally taken into account.	Equipment de-energised when explosive atmosphere is recognised
<b>Apparatus Group II (Surface)</b>	1	Very high	Two independent means of protection or safe even when two faults occur independently of each other.	Equipment remains energised and functioning in Zones 0,1,2 (gas G) or 20, 21, 22 (dust D)
	2	High	Suitable for normal operation and frequently occurring disturbances or equipment where faults are normally taken into account.	Equipment remains energised and functioning in Zones 1, 2 (gas G) or 21, 22 (dust D)
	3	Normal	Suitable for normal operation	Equipment remains energised and functioning in Zones 2 (gas G) or 22 (dust D)

## 2.1.1.3

### CE Mark

The CE marking  $\text{CE}$  symbolises the conformity of the product with the applicable Community requirements imposed on the manufacturer. The CE marking affixed to products is a declaration that the product conforms to all applicable Community provisions and the appropriate conformity assessment procedures have been completed.

Goods for hazardous areas carrying the CE mark may be placed on the market and put into service. Through the application of the Conformity Assessment Procedures, manufacturers can issue an EC Declaration of Conformity, stating compliance with the relevant Directive(s) and apply the CE mark on their equipment.

Components are not CE marked. The manufacturer or his authorized representative will issue a written attestation that declares the conformity of the components with the provisions of this Directive which apply to them and stating their characteristics and how they must be incorporated into equipment or protective systems to assist compliance with the essential requirements applicable to finished equipment or protective systems.

### Presumption of conformity

Where a national standard transposing a harmonized standard, the reference for which has been published in the Official Journal of the European Communities, covers one or more of the essential health and safety requirements, the equipment, protective system, safety device, controlling devices, regulating devices or the component, constructed in accordance with that standard shall be presumed to comply with the relevant essential health and safety requirements. In this case the equipment has to comply to all relevant harmonized standards, the standards for the Explosive atmospheres are only one part of it.

Fig 1 shows the Conformity Assessment Procedures.

Fig 1: Conformity Assessment Procedures

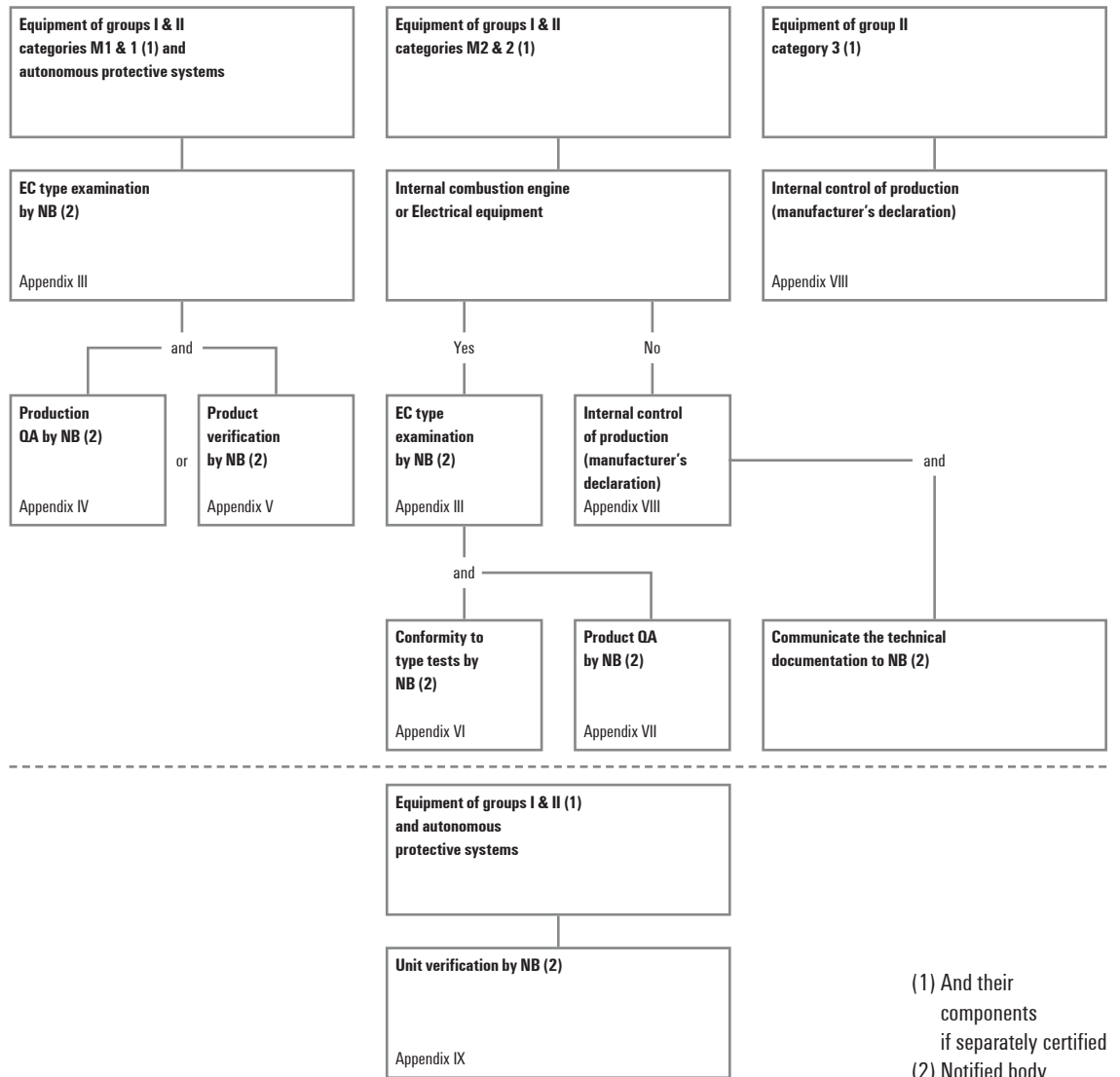

### 2.1.1.4

#### Other Directives that may be applicable

Products might be in the scope of other Directives and the CE mark might have to be applied even if ATEX Directive 2014/34/EU states it is not allowed. The EC Declaration of Conformity is the only way to find out which Directives have been applied to a product.

**Electromagnetic Compatibility Directive 2014/30/EU (EMC)** applies to any product in hazardous area that could cause interference or is susceptible.

Products for use in hazardous areas are explicitly excluded from the **Low Voltage Directive 2014/35/EU (LVD)** but all LVD objectives have to be covered by Directive 2014/34/EU. The standards used for compliance can be listed on the Declaration. However, products that are used outside the hazardous area but are contributing to the safety inside have to comply with both Directives.

The **Machinery Directive 2006/42/EC** contains only general requirements against explosions. Therefore Directive 2014/34/EU takes precedence regarding explosion protection but the Machinery Directive has to be applied to all other relevant risks concerning machines.

### 2.1.1.5

#### Marking

All equipment and protective systems must be marked legibly and indelibly with the following minimum information:

- Name and Full Post Address of the manufacturer,
- CE marking, if involved the identification number or the Notified Body
- Designation of series or type,

- Serial number, if any,
- Year of construction,
- The community mark T
- The equipment group and the category,
- For group II, the letter 'G' (concerning explosive atmospheres caused by gases, vapours or mists) and/or the letter 'D' (concerning explosive atmospheres caused by dust).

Furthermore, where necessary, they must also be marked with all information essential to their safe use. This additional marking is typically a requirement from harmonized standards that are used to demonstrate the compliance to the Essential Health and Safety Requirements of the Directive 2014/34/EU.

Example of marking see fig 2.

Fig 2: Example of marking

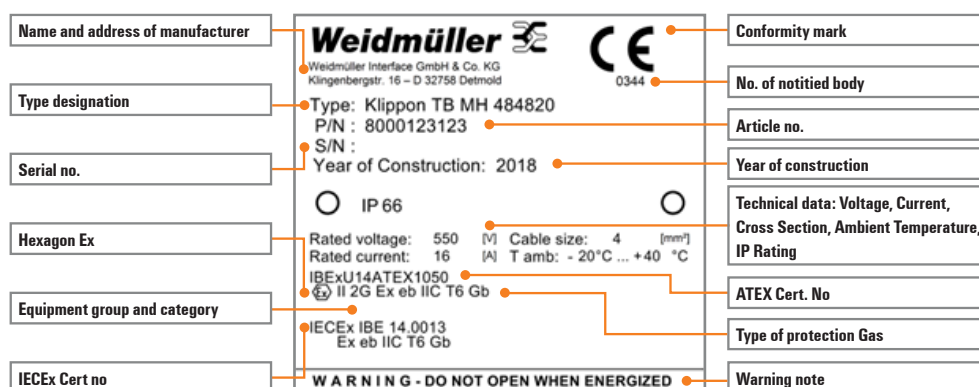

## 2.1.1.6

### Instructions

All equipment and protective systems must be accompanied by instructions, including at least the following information:

- A recapitulation of the information with which the equipment or protective system is marked, except for the serial number, together with any appropriate additional information to facilitate maintenance (e.g. address of the importer, repairer, etc.);
- Instructions for safe:
  - Putting into service,
  - Use,
  - Assembling and dismantling,
  - Maintenance (servicing and emergency repair),
  - Installation,
  - Adjustment;
- Where necessary, an indication of the danger areas in front of pressure-relief devices;
- Where necessary, training instructions;
- Details which allow a decision to be taken beyond any doubt as to whether an item of equipment in a specific category or a protective system can be used safely in the intended area under the expected operating conditions;
- Electrical and pressure parameters, maximum surface temperatures and other limit values;
- Where necessary, special conditions of use, including particulars of possible misuse which experience has shown might occur;
- Where necessary, the essential characteristics of tools which may be fitted to the equipment or protective system.

The manufacturer or his authorized representative established in the Community must draw up the instructions in one of the Community languages. On being put into service, all equipment and protective systems must be accompanied by a translation of the instructions in the language or languages of the country in which the equipment or protective system is to be used and by the instructions in the original language.

Either the manufacturer must make this translation or his authorized representative established in the Community or the person introducing the equipment or protective system into the language area in question.

Maintenance instructions for use by the specialist personnel employed by the manufacturer or his authorized representative established in the Community may be drawn up in a single Community language understood by that personnel.

## 2.1.2

### Directive 1999/92/EC

Directive 1999/92/EC on minimum requirements for improving the safety and health protection of workers potentially at risk from explosive atmospheres

### 2.1.2.1

#### Scope

ATEX Directive 1999/92/EC, is aimed at the employers and requires them to protect workers from the risks of explosive atmospheres. The Directive does not apply to:

- Areas used directly for and during the medical treatment of patients
- The use of appliances burning gaseous fuels in accordance with Regulation (EU) 2016/426
- The manufacture, handling, use, storage and transport of explosives or chemically unstable substances
- Mineral-extracting activities at mines, quarries and offshore installations (Directives 92/91/EEC and 92/104/EEC)
- The use of means of transport by land, water and air, to which the pertinent provisions of the international agreements (e.g. ADN, ADR, ICAO, IMO, RID), and the Community Directives giving effect to those agreements, apply. Means of transport intended for use in a potentially explosive atmosphere shall not be excluded.

### 2.1.2.2

#### Requirements

The employer shall take technical and/or organisational measures appropriate to the nature of the operation, in order of priority and in accordance with the following basic principles:

- Prevent of and protect against explosions
- Assess explosion risks, compile explosion protection document
- Organize that work can be performed safely,
- Ensure appropriate supervising during the presence of workers
- Safety measures must be coordinated in shared workplaces
- Classify workspace in to zones: Zones 0, 1 and 2 for gasses and vapours. Zones 20,21 and 22 for dusts.
- Select equipment in accordance to Directive 2014/34/EU
- Train the workers
- Write instructions and permits to work
- Take explosion protection measures (see Annex II)
- Mark places with an 'EX' sign, where necessary
- Verified the place by a competent person before first time use



Fig 3: Warning sign for places where explosive atmospheres may occur

## 2.1.2.3

### Selection of equipment and protective systems

If the explosion protection document based on a risk assessment does not state otherwise, equipment and protective systems for all places in which explosive atmospheres may occur must be selected on the basis of the categories set out in Directive 2014/34/EU. The following categories of equipment must be used in the zones indicated, provided they are suitable for gases, vapours or mists and/or dusts as appropriate:

- zone 0 use category equipment 1, Equipment Protection Level Ga
- zone 1 use category equipment 1 or 2, Equipment Protection Level Ga or Gb
- zone 2 use category equipment 1 or 2 or 3, Equipment Protection Level Ga or Gb or Gc
- zone 20 use category equipment 1, Equipment Protection Level Da
- zone 21 use category equipment 1 or 2, Equipment Protection Level Da or Db
- zone 22 use category equipment 1 or 2 or 3, Equipment Protection Level Da or Db or Dc

## 2.2

### North America

In North America Canada has adopted the IEC Standards for Explosion Protection of electrical apparatus and, given them a unique CSA identity. The USA has also adopted the Zone Classification concept and new standards have been published based on IEC, but not exactly the same. The protection concepts in the USA are discussed in more detail in Section 6.

## 2.3

### International IECEx Scheme

### 2.3.1

#### IECEx Scheme Objective

The objective of the IECEx Scheme is to facilitate international trade in electrical equipment intended for use in explosive atmospheres (Ex equipment):

- Reduced testing and certification costs to manufacturer
- Reduced time to market
- International confidence in the product assessment process
- One international database listing
- Maintaining international confidence in equipment and services covered by IECEx certification

The final objective of the IECEx Scheme is worldwide acceptance of:

- One standard
- One certificate
- One mark.

### 2.3.2

#### IECEx International Certification Scheme

The aim of the IECEx scheme is to facilitate international trade in Ex equipment intended for use in explosive atmospheres by eliminating the need for multiple national certifications while preserving an appropriate level of safety.

The IECEx scheme is based on the use of specific international IEC standards for type of protection of Ex equipment of IEC/TC31 and is therefore currently limited to electrical equipment (but IEC standards for non-electrical equipment are being developed). IECEx is a type 5 certification scheme (ISO/IEC Guide 67 Conformity assessment).

The IECEx scheme comprises the following three global certification programs

- The **IECEx Certified Equipment Program**
- The **IECEx Certified Service Facilities Program**
- The **IECEx Certification of Personnel Competencies (CoPC)**

## 2.3.2.1

The IECEx Certified Equipment Program provides both

a) A single international certificate of conformity that requires manufacturers to successfully complete:

- Testing and assessment of samples for compliance with standards
- Assessment and auditing of manufacturers premises
- On-going surveillance audits of manufacturers premises

or

b) A “fast-track” process for countries where regulations still require the issuing of national Ex certificates or approval. This is achieved by way of global acceptance of IECEx equipment test and assessment reports.

### IECEX Certificate of Conformity

The Ex IECEx certification body (ExCB) issues an Ex test report (ExTR) covering the product type and a quality assessment report (QAR) covering the related production facility. The Certification body proves the validity and compliance of the quality assessment report with the product and publishes an IECEx certificate of conformity (CoC). These certificates are issued as “Electronic Certificates” and are live on the IECEx Website.

Fig 4: Certificate of Conformity

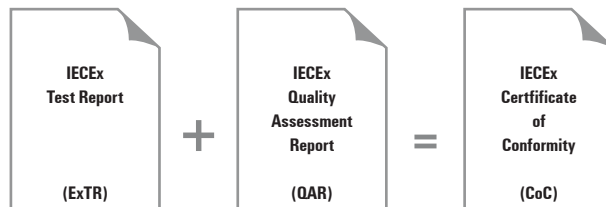

The certificate of conformity will attest that the equipment’s design conforms to the relevant IEC standards and that the manufacturer is manufacturing the product under a quality system and associated quality plan(s), meeting the requirements of this Scheme and under the surveillance of an ExCB

## 2.3.2.2

The IECEx Certified Service Facilities Program

This program covers the assessment and the on-site audit of organisations that provide a repair and overhaul service to the Ex industry.

Ex repair and overhaul facilities and workshops, certified under the IECEx certified service facilities program, provide industry with the assurance that repairs and overhaul to Ex equipment will be undertaken according to the strict requirements of IECEx scheme to the international standard IEC 60079-19.

Like the IECEx certified equipment program, only “Electronic Certificates” are issued via the “On-Line” system thereby giving industry full access to both the viewing and printing of certificates.

## 2.3.2.3

IECEX Certification of Personnel Competencies (CoPC)

This IECEx Scheme is an International Conformity Scheme that provides the global Ex industries with a single system for the assessment and qualification of persons meeting the competency prerequisites needed to properly implement the safety requirements based on the suite of IEC International Standards covering explosive atmospheres, e.g. the IEC 60079 series of standards.

## Section 3

### Basic Principles of Explosive Atmospheres

#### 3.1

##### Explosive atmosphere

An 'explosive atmosphere' is a mixture with air (typically 21 %), under normal atmospheric conditions, of flammable substances in the form of gases, vapours, mists or dusts in a quantity such that it is capable of forming an ignitable vapour/air mixture. After ignition has occurred, combustion spreads to the entire unburned mixture.

The ATEX Directive does not define atmospheric conditions. In conformity to the harmonized standard EN 60079-0 the ambient temperature range is -20 °C to +60 °C and the pressure range is between 0.8 and 1.1. It should be noted that Ex products are usually designed and tested for use in an ambient temperature range of -20 °C to +40 °C, if not otherwise specified by the manufacturer.

#### 3.2

##### Ignition sources

The following ignition sources are examples that can cause an explosion in the right circumstances:

- Hot surfaces
- Flames and hot gas
- Mechanically-generated sparks
- Electrical equipment
- Equalising current
- Static electricity
- Lightning
- Electromagnetic fields
- Optical radiation
- Ionising radiation
- Ultrasonics
- Adiabatic compression
- Chemical reactions

The mechanical ignition sources and their protection concepts are not considered in this guide.

## 3.3

### The Hazard Triangle

The hazard triangle is used to understand the three basic conditions that must be satisfied to create a fire or explosion.

To an explosion it can come only if 3 things are at the same place, at the same time to meet

1. Fuel must be present in sufficient quantity and concentration. This could be a flammable liquid, vapour or combustible dust. See explosion limits in the next section.
2. Supply of oxygen. In natural concentration in air or in increased concentration by supply from process engineering systems.
3. An ignition source.

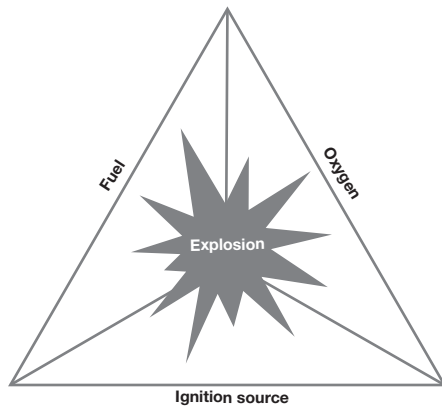

*Fig 5: The Hazard Triangle*

Successfully suppressing or separating one or more of these three components can avoid a fire or explosion. We will be looking at a number of protection concepts for gasses and vapours as well as dust atmospheres. All of which use these simple principles.

# Section 4

## Gases and Vapours

### 4.1

#### Characteristics of gases and vapours

### 4.1.1

#### Principles

Different safety relevant properties of substances can be obtained by laboratory experiments.

Basically all gasses and vapours require oxygen to make them flammable. Too much or too little oxygen and the mixture will not ignite.

The properties of the mixture gives information about a substance's burning behaviour. The relevant properties are e.g.

- flash point
- ignition temperature
- explosion limits
- limiting oxygen concentration

### 4.1.1.1

#### Flash point

Flash points are normally associated with liquids but a few materials give off vapours when still in the solid state. The flash point of a flammable substance is the minimum temperature at which the material gives off vapours in a quantity such that it is capable of forming an ignitable vapour/air mixture. The combustible gas or vapour will ignite momentarily on application of an effective ignition source.

### 4.1.1.2

#### Ignition temperature

The ignition temperature of a flammable substance is the minimum temperature at which the material will ignite and sustain combustion. This is also known as the 'Auto Ignition Temperature'.

### 4.1.1.3

#### Explosion Limits

If the concentration of a sufficiently dispersed flammable substance in air exceeds a minimum value (the lower explosion limit – LEL), an explosion is possible. No explosion occurs if the concentration exceeds a maximum value (the upper explosion limit – UEL).

Explosion limits change under conditions other than atmospheric. The range of concentrations between the explosion limits widens, e.g. generally as the pressure and temperature of the mixture increase. An explosive atmosphere can form above a flammable liquid only if the temperature of the liquid exceeds a minimum value.

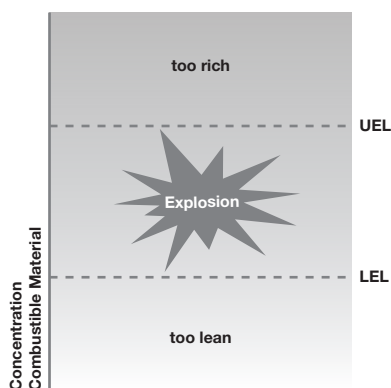

Fig 6: Explosion Limits

### 4.1.1.4

#### Maximum oxygen concentration

The maximum oxygen concentration in a mixture of a flammable substance and air and an inert gas, in which an explosion will not occur, determined under specified test conditions.

### 4.1.1.5

#### Vapour density

Vapour density of a gas is given relative to that of air. Many gases are lighter than air. Any vapour release will rise and dilute rapidly. When indoors, these gases will collect in the roof space. Where gases are heavier than air they will fall to the lowest point and fill sumps, trenches or hollows in the ground. These gases can remain there long after the release has been stopped and continue to pose a danger.

### 4.1.1.6

#### Ignition requirements/minimum ignition energy

In order to ignite a gas or vapour, a spark needs a certain amount of energy. The minimum ignition energy is the spark energy in Joules, required to ignite the gases. Another parameter is the **Minimum Ignition Current (MIC)**. The Minimum Ignition Current is mostly used as a ratio relative to that of methane.

### 4.1.1.7

#### Maximum Experimental Safe Gap (MESG)

The behaviour of the explosive atmosphere after ignition is relevant for the design of equipment designed to limit the damage caused by an explosion. To introduce the explosion groups the relevant parameter is called the **Maximum Experimental Safe Gap (MESG)**.

The gas inside the test chamber is ignited. A gap exists between the cover and the chamber with a gap length of 25 mm. The hot burning gas is now forced through the narrow gap. If the escaping gas ignites the surrounding gas, the test will have to be repeated with a smaller gap. The gap, which prevents the ignition of the surrounding gas, is the MESG.

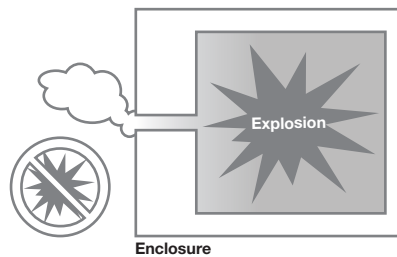

Fig 7: MESG

## 4.1.2

### Explosion Group

Electrical apparatus for use in flammable gases and vapours are divided into groups:

**Group I** is for electrical or mechanical apparatus for mines susceptible to fire damp. Group I equipment will not be discussed in this guide.

**Group II** is for electrical and mechanical apparatus used in places other than mines.

Gases of Group II are further divided into sub-divisions i.e. IIA, IIB and IIC. The sub-divisions are based on experimental work conducted with flameproof and intrinsically safe apparatus. This sub-division is also called the explosion group.

To categorise gases the Maximum Experimental Safe Gap (MESG) and/or the Minimum Ignition Current (MIC) can be used.

Table 2: **Explosion Group**

Explosion Group	Maximum Experimental Safe Gap (MESG)	Minimum Ignition Current (MIC)
IIA	> 0,9 mm	> 0,8
IIB	0,5 to 0,9 mm	0,45 to 0,8
IIC	< 0,5 mm	< 0,45

Table 3: **Gas Group**

Gas	Gas Group
Acetylene	IIC
Hydrogen	IIC
Ethylene	IIB
Methanol	IIA
Propane	IIA

A piece of apparatus classified as IIC may also be used in a IIA and IIB application, a piece of apparatus designated as IIB can also be used in a IIA but NOT in a IIC application and apparatus designated as IIA can ONLY be used in a IIA application.

## 4.1.3

### Temperature classification

The maximum surface temperature of electrical or mechanical apparatus must always be lower than the ignition temperature of the surrounding explosive atmosphere. The ignition temperature of different gases varies considerably. A mixture of air with hydrogen will ignite at 560 °C but a mixture of air with diethyl ether will ignite at 170 °C.

To help manufacturers design their equipment, apparatus are given a temperature classification consisting of 6 temperatures ranging from 85 °C (T6) to 450 °C (T1). The 6 'T' classes are given in Table 4.

Table 4: **Maximum surface temperature for group II electrical apparatus**

Temperature class	Maximum surface temperature of apparatus in °C	Ignition temperature of the flammable substances in °C
T1	450	> 450
T2	300	> 300 ≤ 450
T3	200	> 200 ≤ 300
T4	135	> 135 ≤ 200
T5	100	> 100 ≤ 135
T6	85	> 85 ≤ 100

Apparatus will be marked according to the maximum surface temperature of any relevant part that might be in contact with the flammable gas. For 'Flameproof' and 'Pressurised' equipment the maximum surface temperature is on the outside of the enclosure, whereas for 'Increased Safety' the hottest point is inside. The temperature classification for Group II electrical apparatus will be either:

- T class as given in Table above
- Actual maximum surface temperature
- Specific gas for which it is designed

Apparatus suitable for e.g. T3 temperature class can also be used in T1 and T2.

Electrical apparatus shall normally be designed for use in an ambient temperature of **-20 °C and +40 °C**. When designed for use in a different range, the ambient temperature must be stated by the manufacturer and specified in the certificate. The marking must include either the special temperature range e.g.  $-35^{\circ}\text{C} \leq T_a \leq +55^{\circ}\text{C}$ , or the letter 'X' after the certificate number.

Table 5 gives the classification of some gases in explosion groups and temperature classes.

Table 5: Classification of some gases in explosion groups and temperature classes

	T1	T2	T3	T4	T5	T6
I	Methane					
IIA	Acetone Ammonia Benzene Carbon monoxide Ethane Methanol Propane	Butane Ethanol	Cyclohexane Kerosene Petroleum Turpentine Pentane	Acetaldehyde		
IIB		Ethylene				
IIC	Hydrogen	Acetylene				Carbon disulphide

## 4.2

### 4.2.1

#### Area classification

##### General

Installations in which flammable materials are manufactured, handled or stored should be designed, operated and maintained so that any releases of flammable material and the extent of hazardous areas are kept to a minimum.

In situations where there may be an explosive gas atmosphere, the following steps should be taken:

- Eliminate the likelihood of an explosive gas atmosphere occurring around the source of ignition; or
- Eliminate the source of ignition; or
- Limit the range of explosion flames and explosion pressures to a sufficient level of safety

Where this is not possible, protective measures, process equipment, systems and procedures should be selected so the likelihood of both being present at the same time is acceptable small. In first instance it is preferable to eliminate the presence of a flammable atmosphere. This is possible by:

- Substituting with a non-flammable substance; or
- Raising the flash point above the process temperature e.g. adding water
- Lowering the process temperature e.g. cooling
- Limiting the concentration below the LEL e.g. dilution/ventilation or inerting
- Explosion-proof design (containment)

In practice however, it is very difficult to ensure that an explosive gas atmosphere will never occur. In this case, apparatus with special protective measures should be used.

### 4.2.2

#### Definitions of zones

A hazardous place is a place in which an explosive atmosphere may occur in such quantities as to require special precautions to protect workers against explosion hazards. Such a quantity is termed a hazardous explosive atmosphere. As a basis for determining the extent of protective measures, any remaining hazardous places must be classified in terms of zones according to the likelihood of occurrence of such atmospheres. The classification is covered by EN 60079-10-1 (Gas) and EN 60079-10-2 (Dust).

#### 4.2.2.1

##### Zone 0

A place in which an explosive atmosphere consisting of a mixture with air of flammable substances in the form of gas, vapour or mist is present continuously or for long periods or frequently.

#### 4.2.2.2

##### Zone 1

A place in which an explosive atmosphere consisting of a mixture with air of flammable substances in the form of gas, vapour or mist is likely to occur in normal operation occasionally.

### 4.2.2.3

#### Zone 2

A place in which an explosive atmosphere consisting of a mixture with air of flammable substances in the form of gas, vapour or mist is not likely to occur in normal operation but, if it does occur, will persist for a short period only.

### 4.2.2.4

#### Examples of zone identification

Flammable liquid storage tank, situated outdoors, with fixed roof and no internal floating roof:

*Fig 8: Flammable liquid storage tank*

Taking into account relevant parameters, the following are typical values which will be obtained for this example:

- a = 3 m from vent openings**
- b = 3 m above the roof**
- c = 3 m horizontally from the tank**

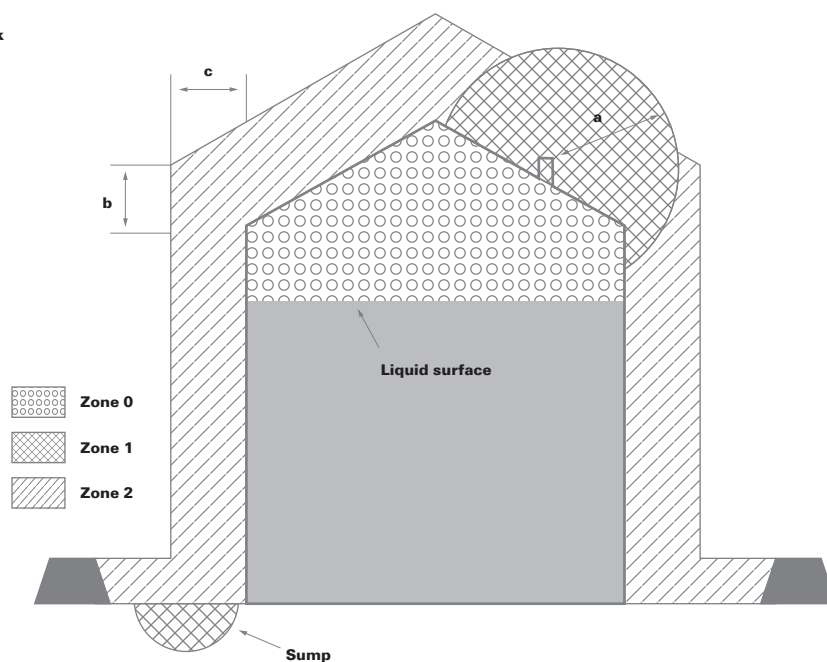

Single tanker filling installation (during filling), situated outdoors, for gasoline, top filling with no vapour recovery:

Fig 9: Single tanker filling installation

Taking into account relevant parameters, the following are typical values which will be obtained for this example:

- a = 1,5 m horizontally from source of release
- b = 1,5 m horizontally from flexible joint
- c = 1,5 m above source of release
- d = 1,0 m above ground level
- e = 4,5 m horizontally from drainage channel/gantry
- f = 1,5 m horizontally from zone 1
- g = 1,0 m above zone 1

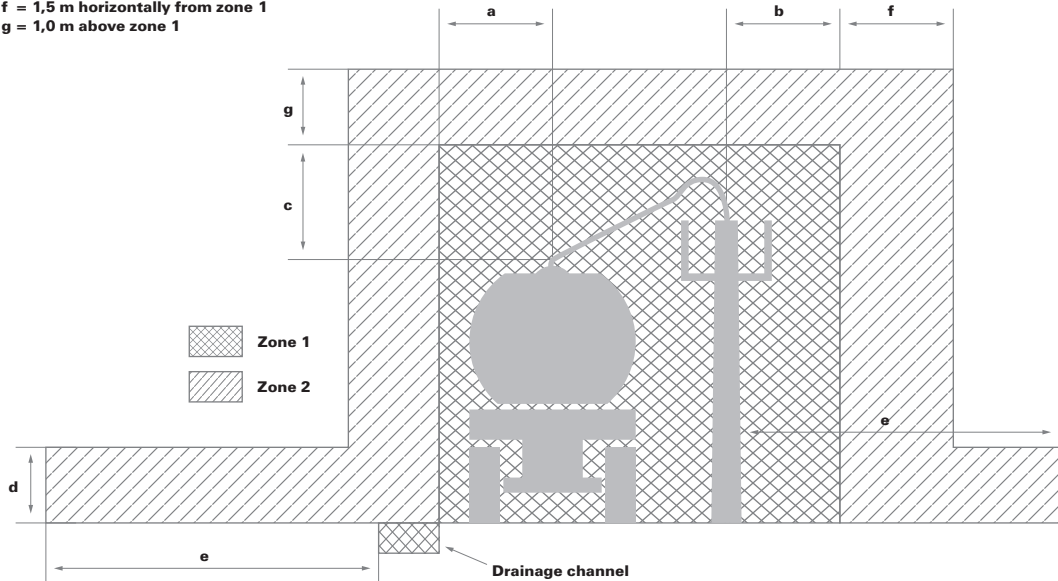

## 4.2.3

### Sources of release

The basic elements for establishing the hazardous zone types are the identification of the source of release and the determination of the grade of release. Each item of process equipment e.g. tank, pump, pipeline, vessel, etc., should be considered as a potential source of release. Items, which contain flammable material but cannot release it to the atmosphere e.g. all-welded pipeline, are not considered to be sources of release.

### 4.2.3.1

#### Grades of release

Releases are categorised as follows:

#### Continuous Grade of release

A release, which is continuous or is expected to occur for long periods.

Examples of Continuous Grade of release:

- Surface of a flammable liquid in a fixed roof tank
- Surface of an open reservoir e.g. oil/water separator

#### Primary Grade of release

A release which can be expected to occur periodically or occasionally during normal operation.

Examples of Primary Grade of release:

- Seals of pumps, compressors or valves that are expected to release flammable material, particularly during start-up.
- Water drainage points on vessels, which contain flammable liquids.
- Sample points from which analytical samples are drawn.
- Relief valves, vents and other openings, which are expected to release during normal operation.

### **Secondary Grade of release**

A release, which is not expected to occur in normal operation and if it does occur, is likely to do so only infrequently for short periods. Examples of Secondary Grade of release:

- Seals of pumps, compressors or valves that are not expected to release flammable material during normal operation.
- Flanges, connections and pipe fittings where release of flammable materials is not expected during normal operation
- Relief valves, vents and other openings, which are not expected to release during normal operation.

A continuous grade of release normally leads to a zone 0, a primary grade to zone 1 and a secondary grade to zone 2.

## 4.2.3.2

### **Extent of zone**

Quite a number of factors can influence the extent of the zone. If the gas is lighter than air, it rises on release and can become trapped in the roof space; or if the gas is heavier than air, it will fall and spread at ground level. This has an impact on the location of the site, is it on a hill or in a hollow?

When sources of release are in an adjacent area, the migration can be prevented by:

- Physical barriers
- Static overpressure in the area adjacent to the hazardous area.
- Purging the area with a significant airflow.

## 4.2.3.3

### **Ventilation**

Gas or vapour released into the atmosphere can be diluted by dispersion or diffusion into the air until its concentration is below the lower explosive limit. Suitable ventilation rates can influence the type of zone.

There are two types of ventilation available:

- Natural ventilation
- Artificial ventilation, general or local

Natural ventilation is created by the movement of air caused by the wind and/or by temperature gradients.

Artificial ventilation is provided by artificial means e.g. fans or extractors. With the use of artificial ventilation it is possible to achieve:

- Reduction in the extent of the zone
- Shortening of the time of persistence of an explosive atmosphere
- Prevention of the generation of an explosive atmosphere

### **The three degrees of ventilation**

#### **High ventilation (VH)**

Can reduce the concentration at the source of release virtually instantaneously, resulting in a concentration below the lower explosive limit. A zone of negligible extent results.

#### **Medium ventilation (VM)**

Can control the concentration, resulting in a stable zone boundary, whilst the release is in progress, and where the explosive gas atmosphere does not persist unduly after the release has stopped. The extent and type of the zone depend on the design parameters.

#### **Low ventilation (VL)**

Cannot control the concentration whilst release is in progress and/or cannot prevent undue persistence of a flammable atmosphere after release has stopped.

### **Availability of ventilation**

Three levels of availability of ventilation should be considered

## Good

Ventilation is present virtually continuously

Natural ventilation which is generally obtained outdoors, is considered to be good when the wind speed is greater than 0.5 m/s (approx 1.1 miles per hour)

## Fair

Ventilation is expected to be present during normal operation. Interruptions are permissible provided that they occur infrequently and for short periods.

## Poor

Ventilation, which does not meet the standard of fair or poor, but interruptions are not expected to occur for long periods. Ventilation, which is less than poor, is ignored.

Table 6: Influence of ventilation on type of zone

Grade of release	Ventilation						
	Degree						
	High			Medium			Low
	Availability						
	Good	Fair	Poor	Good	Fair	Poor	Good, Fair or Poor
Continuous	(zone 0 NE) Non-Haz <sup>1)</sup>	(zone 0 NE) zone 2 <sup>1)</sup>	(zone 0 NE) zone 1 <sup>1)</sup>	zone 0	zone 0 + zone 2	zone 0 + zone 1	zone 0
Primary	(zone 1 NE) Non-Haz <sup>1)</sup>	(zone 1 NE) zone 2 <sup>1)</sup>	(zone 1 NE) zone 2 <sup>1)</sup>	zone 1	zone 1 + zone 2	zone 1 + zone 2	zone 1 or zone 0 <sup>3)</sup>
Secondary <sup>2)</sup>	(zone 2 NE) Non-Haz <sup>1)</sup>	(zone 2 NE) Non-Haz <sup>1)</sup>	zone 2	zone 2	zone 2	zone 2	zone 1 and even zone 0 <sup>3)</sup>

<sup>1)</sup> Zone 0 NE, 1 NE, 2 NE indicates a theoretical zone which would be of negligible extent

<sup>2)</sup> The zone 2 area created by a secondary grade release may exceed that attributable to a primary or continuous grade release; in which case, the greater distance should be taken

<sup>3)</sup> Will be zone 0 if the ventilation is so weak and the release is such that in practice an explosive atmosphere exists virtually continuously

Note: '+', signifies 'surrounded by'

## 4.2.4

### Equipment protection level (EPL)

A risk assessment approach for the acceptance of Ex equipment has been introduced as an alternative method to the current prescriptive and relatively inflexible approach linking equipment to zones. To facilitate this, a system of equipment protection levels has been introduced to clearly indicate the inherent ignition risk of equipment, no matter what type of protection is used.

The EPL is a level of protection assigned to equipment based on its likelihood of becoming a source of ignition and distinguishing the differences between explosive gas atmospheres, explosive dust atmospheres, and the explosive atmospheres in mines susceptible to firedamp.

#### EPL Ga

Equipment for explosive gas atmospheres, having a „very high“ level of protection, which is not a source of ignition in normal operation, during expected malfunctions or during rare malfunctions

#### EPL Gb

Equipment for explosive gas atmospheres, having a „high“ level of protection, which is not a source of ignition in normal operation or during expected malfunctions,

#### EPL Gc

Equipment for explosive gas atmospheres, having a „enhanced“ level of protection, which is not a source of ignition in normal operation and which may have some additional protection to ensure that it remains inactive as an ignition source in the case of regular expected occurrences (for example failure of a lamp)

Table 7: Traditional relationship of EPLs to zones (no additional risk assessment)

EPL	Zone
Ga	1
Gb	2
Gc	3

## 4.3

### 4.3.1

#### Gas explosion protection concepts for electrical equipment

##### Zones of use

To protect workers against explosion hazards equipment and protective systems for all places in which explosive atmospheres may occur must be selected on the basis of the categories set out in Directive 2014/34/EU, if the explosion protection document on a risk assessment does not state otherwise.

In particular, the following categories of equipment must be used in the zones indicated, provided they are suitable for gases, vapours or mists and/or dusts as appropriate:

- in zone 0, category 1 equipment,
- in zone 1, category 1 or 2 equipment,
- in zone 2, category 1, 2 or 3 equipment.

Several methods may be used to make equipment safe for use in an explosive atmosphere. Table 8 gives an overview of the available concepts and their principles.

Table 8: **Electrical equipment for gases, vapours and mists (G)**

Type of Protection	Symbol	Category	Zone	EPL	Standard	Basic concept of protection
Gas Application						
Increased Safety	eb	2	1	Gb	EN 60079-7	No arcs, sparks or hot surfaces
	ec	3	2	Gc		
Non-Sparking	nA	3	2	Gc	EN 60079-15	
Flameproof	db	2	1	Gb	EN 60079-1	Contains the source of ignition, prevent flame propagation
Enclosed Break	nC	3	2	Gc	EN 60079-15	
Intrinsic Safety	ia	1	0	Ga	EN 60069-11	Limit the energy of the spark, the light energy and the surface temperature
	ib	2	1	Gb		
	ic	3	2	Gc		
inherently safe optical radiation	op is	1	0	Ga	EN 60079-28	
		2	1	Gb		
		3	2	Gc		
Pressurised	p	2	1	Gb	EN 60079-2	Keep the flammable gas out
Restricted Breathing	nR	3	2	Gc	EN 60079-15	
Simple Pressurisation	nP	3	2	Gc	EN 60079-15	
Encapsulation	ma	1	0	Ga	EN 60079-18	
Encapsulation	mb	2	1	Gb	EN 60079-18	
Encapsulation	mc	3	2	Gc	EN 60079-18	
Oil Immersion	o	2	1	Gb	EN 60079-6	
Quartz/ Sand Filled	q	2	1	Gb	EN 60079-5	
protected optical radiation	op pr	2	1	Gb	EN 60079-28	
Dust application						
Protection by enclosure	ta	1	20	Da	EN 60079-31	Keep the flammable dust out
	tb	2	21	Db		
	tc	3	22	Dc		
Intrinsic Safety	ia	1	20	Da	EN 60079-11	Limit the energy of the spark, the light energy and the surface temperature
	ib	2	21	Db		
	ic	3	22	Dc		
inherently safe optical radiation	op is	1	20	Ga	EN 60079-28	
		2	21	Gb		
		3	22	Gc		
protected optical radiation	op pr	2	21	Db	EN 60079-28	Keep the flammable dust out additional mechanical protection

## 4.3.2

### 4.3.2.1

#### Protection concepts

##### Increased Safety 'e'

##### Basic principles

Increased safety is intended for products in which arcs and sparks do not occur in normal or under fault conditions. The surface temperatures of the relevant parts are controlled below incandive values. Increased safety is achieved by reducing current ratings and enhancing insulation values and creepage and clearance distances above those required for normal service. Maximum voltage for the protection concept is 11kV (d.c. or a.c. r.m.s.).

The protection concept provides a high level of safety in accordance to Directive 2014/34/EU, making it suitable for Category 2 and 3 and Group IIA, IIB and IIC.

Typical products are junction boxes, luminaries, induction motors, transformers and heating devices. The key design features for increased safety are:

- Enclosures must be constructed such that they can withstand the mechanical impact test and provide a specified degree of ingress protection. Non-metallic materials must comply with the following requirements:
  - Thermal endurance to heat
  - Thermal endurance to cold
  - Resistance to light
  - Insulation resistance
  - Thermal Index (TI)
- Terminals must be generously dimensioned for the intended connections and ensure that the conductors are securely fastened without the possibility of self-loosening.
- Clearance between bare conductive parts must not be less than the values specified for the rated voltage
- Creepage distances must not be less than the values specified for the rated voltage and the comparative tracking index (CTI) of the insulating material.
- Electrical insulating materials must have mechanical stability up to at least 20 K above the maximum service temperature.
- Temperatures of parts of equipment must be limited so as not to exceed values that could affect the thermal stability of the material and the temperature classification of the equipment.

### Junction boxes

**Ex e enclosures** that contain bare conductive parts require an ingress protection of IP 54. If only insulated conductive parts are fitted, IP 44 will suffice. In practice however, users require enclosures with an ingress protection of IP 66 or higher. Enclosures may be provided with drain holes or ventilation openings to prevent the accumulation of condensation. The ingress protection may be reduced but no less than IP44 when fitted with bare conductive parts or IP24 when fitted with insulated conductive parts. However, breather drains maintaining IP 66 or higher are available on the market (see fig 10).

Fig 10: Example Breather Drain

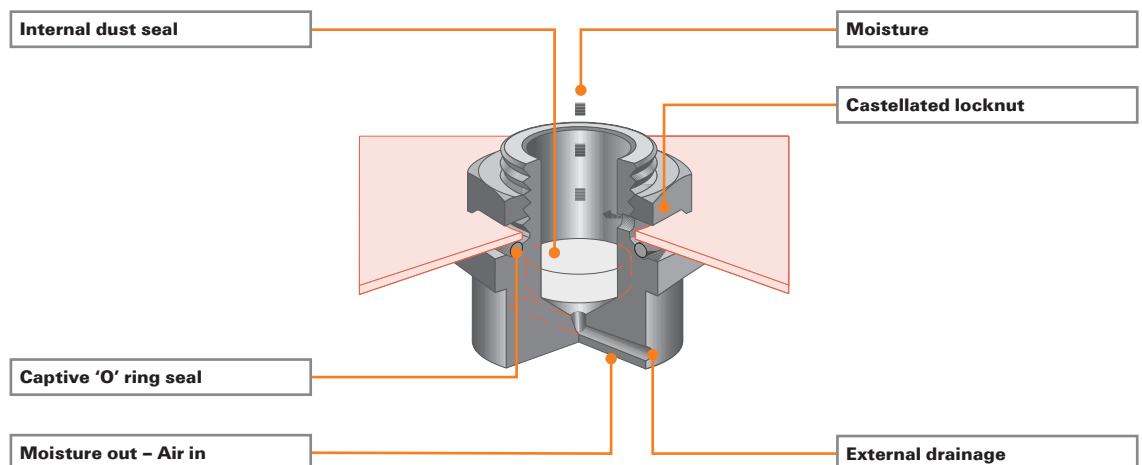

One of the main advantages of increased safety enclosures is the availability in different construction materials such as, stainless, mild steel, aluminium, glass fibre reinforced polyester, polycarbonate, etc.

The basic requirements for **Ex e terminals** are in accordance with EN 60947-7-1 and EN 60947-7-2. For use in hazardous areas, standards EN 60079-0 and EN 60079-7 also apply. Ex terminals are classified as components in Directive 2014/34/EU, which means that they are not CE marked.

Different types of connection are now possible. The Weidmüller clamping yoke, tension clamp, PUSH IN and Insulation Displacement Connection (IDC) clamping system provide protection against self-

loosening and the design is such that stranded cable does not have to be crimped with ferrules. The cross-section of the cable and other connection data specified in the selection tables are included in the EC Type examination certificate. The specified values of the current carrying capacity are based on an ambient temperature of 40 °C. At rated current (+10%), the surface temperature of the current bar of the terminal block is maximum 40K. The maximum operating temperature in a hazardous area atmosphere of the insulating material Wemid is 100 °C or 110 °C, Melamine (KRG) 130 °C, and 80 °C for Polyamide (PA).

Fig 11: Connection technology

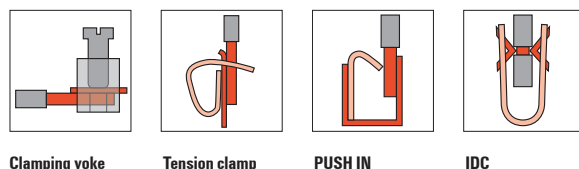

Accessories that can be fitted to the terminals are also listed on the EC Type examination certificate. The standard has made it possible to use pluggable cross connections. When using the WDU 2.5 from Weidmüller, it is even possible to fit 3 rows of cross connections in parallel. Users can fit cross connection on-site but have to follow the instructions provided by the manufacturer. Fitting cross connection might result in lower voltages and lower currents.

Ex e junction boxes have a maximum surface temperature, which is normally inside the enclosure. This defines the temperature classification of the enclosure. The temperature is determined by test and depends on two factors:

- Number of terminals and wiring inside
- Temperature rise of terminals and wiring above ambient

Normal ambient temperature is -20 °C to +40 °C. Higher ambient temperatures could mean a higher T class or reducing the current through the terminals.

Enclosures are allocated a Maximum Dissipated Power figure, which is used to calculate the number of terminals that can be fitted. Based on a derated current stated in the Notice to Installers (NTI) and the total resistance of cable and terminal, the user or manufacturer calculates the dissipated power per terminal. This figure multiplied by the number of terminals must always be lower than the MDP figure allocated to the enclosure.

Alternatively, the user can be provided with a table for each enclosure size, indicating the maximum number of terminals or conductors based on the rated current and cross section i.e. the 'Defined Arrangement Method'.

For each enclosure size, there is one terminal or conductor content table which shows the permissible values for that particular junction box. The user might decide to fit terminals which can terminate a cable size of 4 mm<sup>2</sup> but instead uses 2.5 mm<sup>2</sup> for the wiring. In that case it is not the number of 4 mm<sup>2</sup> terminals that is important but the number of 2.5 mm<sup>2</sup> cable pairs that are being connected. Cross connections and ground wires can be neglected, in calculating the number of wires.

In the white area of the content table the permitted numbers of current carrying conductors inside the enclosure are indicated (in and out counts two wires) depending on wire size and continuous current. In the Green Area of the content table additional conductors/terminals are permitted up to the space limit of the enclosure. In the orange area no conductors/terminals are permitted.

Table 9: Klippon TB MH

		Cross-section [mm <sup>2</sup> ]															
		1,5	2,5	4	6	10	16	25	35	50	70	95	120	150	185	240	300
Current [A]		Maximum number of conductors															
	6																
	10	80	146														
	15	36	62	106													
	21		30	52	86												
	26			32	54	134											
	36				24	48	152										
	50					22	44	140									
	66						20	42	90								
	88							18	32	70							
	109								18	32	82						
	131									18	36						
	167										16	30	56				
	202											16	26	44			
	224												18	28	60		
	267													16	24	72	
	307															14	28
361																14	26
452																	10

**Example**

KLIPPON TB MH 624520 fitted with a number of WDU 4 terminals, i.e. 1 bank of 72 terminals. The wiring is with 2.5 mm<sup>2</sup> cable and the rated current for your application is 10 Amps. From the table, you could connect 146 of 2.5 mm<sup>2</sup> cables (73 pairs) or 73 WDU 4 terminals (terminal with 2 clamping yokes). If you want to use the 2 banks of 72 WDU 4 you have to reduce the current load to 6 Amps to remain within the T6 classification (-20 °C < Tamb < +40 °C). Alternatively, if you would be able to reduce the number of terminals to 73, the current of 10 Amps is safe.

Be aware that the table is calculated to remain the T-classification and does not take into account the physical dimensions. It is possible that the number of terminals will not fit inside the enclosure.

Other examples and the calculation method for mixed content are detailed in Appendix III.

**Ed de control stations**

All sparking devices such as switches, contactors, lamps, thermal relays, etc. are packaged individually in a flameproof enclosure. The electrical connection is made via Ex e terminals included in the design or by means of an encapsulated cable. These components are then installed in an Ex e enclosure.

Fig 12: Control Station



### Cable entry devices



Cable glands must maintain at least IP 54. The cable glands require an EC Type Examination Certificate by a Notified Body for the protection type increased safety Ex e. For example a certification for flameproof Ex d only is not sufficient for increased safety Ex e certified enclosures. Cable glands are typically equipment certified.

When the temperature under rated conditions is higher than 70 °C at the entry point or 80 °C at the branching point of the conductors, the electrical apparatus shall be appropriately marked to provide guidance to the user on the proper selection of cable gland and cable or conductors. Unused entries must be fitted with suitable component approved stopping plugs. The plug must require the use of a tool to remove it.

Some countries prefer the flexibility of transit systems in enclosures. The system can be certified as part of the enclosure or assembly certification, or have its own component approval.

## 4.3.2.2

### Flameproof 'd'

#### Basic principles

Flameproof enclosures are intended for equipment, which produces arcs, sparks or hot surfaces that may be incendive in normal operation or industrial components that cannot otherwise be made suitable for use in a hazardous area. The surrounding explosive atmosphere can enter the enclosure and internal explosions are expected during the life of the equipment. The enclosure therefore has to be strong enough not to fracture or distort under the pressures generated. Any constructional joints in the enclosure are dimensioned such that they do not transmit the explosion from the inside to the surrounding atmosphere. These are called flamepaths.

The equipment is designed according to EN 60079-1 and is suitable for gas group II, category 2.

Typical products are electric motors and actuators, luminaries, loudspeakers and switchgear.

The key design features are:

- Enclosures must be sufficiently strong to withstand the internal explosion
- Joints and gaps have critical dimensions
- Covers have warning labels if the enclosure contains parts that store energy or achieve temperatures in excess of the temperature classification
- Fasteners must conform to dimensional and strength requirements
- Enclosure materials must be fully specified and non-metallic materials must be fully defined and have a suitable thermal index (TI).
- Cable and conduit entries must meet constructional requirements so that the flameproof properties are maintained.

#### Flamepaths, gaps, flanges and threaded joints

A flamepath is any small joint or gap in a flameproof enclosure through which the hot gases of an internal explosion might pass. When escaping through the gaps the hot gases are sufficiently cooled down that they do not ignite the surrounding atmosphere. The standard specifies the maximum permissible gaps for flanges, spigots and other types of joints based experimental testing.

The table 10 shows the values based on volume, gas sub-division and type of joint. Cylindrical threads must have at least 5 full threads of engagement. In practice 6 threads are usually provided. If the thread has an undercut, then a non-detachable and non-compressible washer shall be fitted to ensure the right thread engagement.

Table 10: Permissible flange gaps and joints

Type of joint	Minimum width of joint L mm	Maximum gap mm												
		For a volume cm <sup>3</sup> V ≤ 100			For a volume cm <sup>3</sup> 100 < V ≤ 500			For a volume cm <sup>3</sup> 500 < V ≤ 2000			For a volume cm <sup>3</sup> V > 2000			
		I	IIA	IIB	I	IIA	IIB	I	IIA	IIB	I	IIA	IIB	
Flanged, cylindrical or spigot joints	6	0,30	0,30	0,20	-	-	-	-	-	-	-	-	-	
	9,5	0,35	0,30	0,20	0,35	0,30	0,20	-	-	-	-	-	-	
	12,5	0,40	0,30	0,20	0,40	0,30	0,20	0,40	0,30	0,20	0,40	0,20	0,15	
	25	0,50	0,40	0,20	0,50	0,40	0,20	0,50	0,40	0,20	0,50	0,40	0,20	
Cylindrical joints for shaft glands of rotating electrical machines with:	Sleeve bearings	6	0,30	0,30	0,20	-	-	-	-	-	-	-	-	-
		9,5	0,35	0,30	0,20	0,35	0,30	0,20	-	-	-	-	-	-
		12,5	0,40	0,35	0,25	0,40	0,30	0,20	0,40	0,30	0,20	0,40	0,20	-
		25	0,50	0,40	0,30	0,50	0,40	0,25	0,50	0,40	0,25	0,50	0,40	0,20
		40	0,60	0,50	0,40	0,60	0,50	0,30	0,60	0,50	0,30	0,60	0,50	0,25
	Rolling element bearings	6	0,45	0,45	0,30	-	-	-	-	-	-	-	-	-
		9,5	0,50	0,45	0,35	0,50	0,40	0,25	-	-	-	-	-	-
		12,5	0,60	0,50	0,40	0,60	0,45	0,30	0,60	0,45	0,30	0,60	0,30	0,20
		25	0,75	0,60	0,45	0,75	0,60	0,40	0,75	0,60	0,40	0,75	0,60	0,30
		40	0,80	0,75	0,60	0,80	0,75	0,45	0,80	0,75	0,45	0,80	0,75	0,40

Note: Constructional values rounded according to ISO 31-0 should be taken when determining the maximum gap

Table 11: Permissible flange gaps and joints for group IIC enclosures

Type of joint	Minimum width of joint L mm	Maximum gap mm			
		For a volume cm <sup>3</sup> V ≤ 100	For a volume cm <sup>3</sup> 100 < V ≤ 500	For a volume cm <sup>3</sup> 500 < V ≤ 2000	For a volume cm <sup>3</sup> V > 2000
Flanged joints a	6	0,10	-	-	-
	9,5	0,10	0,10	-	-
	15,8	0,10	0,10	0,04	-
	25	0,10	0,10	0,04	0,04
Spigot joints (Figure 15)	c ≥ 6 mm	12,5	0,15	0,15	0,15
	d ≥ 0,5 L	25	0,18 <sup>b</sup>	0,18 <sup>b</sup>	0,18 <sup>b</sup>
	L = c + d	40	0,20 <sup>c</sup>	0,20 <sup>c</sup>	0,20 <sup>c</sup>
	f ≤ 1 mm				
Cylindrical joints Spigot joints (Figure 16)	6	0,10	-	-	-
	9,5	0,10	0,10	-	-
	12,5	0,15	0,15	0,15	-
	25	0,15	0,15	0,15	0,15
	40	0,20	0,20	0,20	0,20
Cylindrical joints for shaft glands of rotating electrical machines with rolling element bearings	6	0,15	-	-	-
	9,5	0,15	0,15	-	-
	12,5	0,25	0,25	0,25	-
	25	0,25	0,25	0,25	0,25
40	0,30	0,30	0,30	0,30	

<sup>a</sup> Flanged joints are permitted for explosive mixtures of acetylene and air only if the gap is ≤ 0,04 mm and L ≥ 9,5 mm, and then only for enclosures having a volume not exceeding 500 cm<sup>3</sup>

<sup>b</sup> Maximum gap of cylindrical part increased to 0,20 mm if f < 0,5 mm

<sup>c</sup> Maximum gap of cylindrical part increased to 0,25 mm if f < 0,5 mm

Note: Constructional values rounded according to ISO 31-0 should be taken when determining the maximum gap

Fig 15: Cylindrical part and plane part

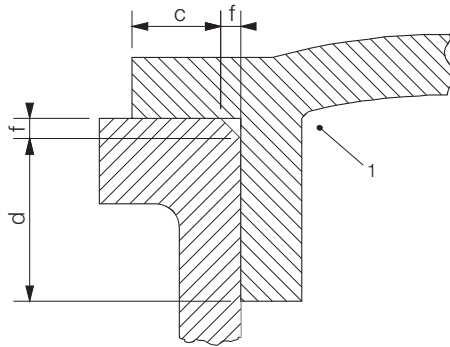
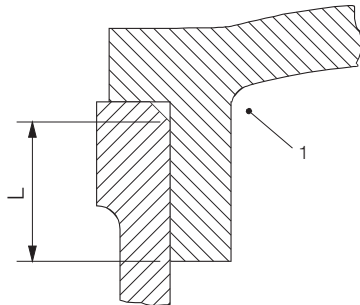

Fig 16: Cylindrical part only



**Key**

$L = c + d$  (I, IIA, IIB, IIC)

$c \geq 6.0$  mm (IIC)

$\geq 3.0$  mm (I, IIA, IIB)

$d \geq 0.50 L$  (IIC)

$f \leq 1.0$  mm (I, IIA, IIB, IIC)

1 Interior of enclosure

If an internal explosion does happen, some of the hot gases will pass through the gaps in the enclosures. It is very important that these gases pass freely into the atmosphere therefore a minimum distance is required between the gap and any solid obstruction.

Table 12: Minimum distance

Apparatus group	Minimum distance
IIA	10 mm
IIB	30 mm
IIC	40 mm

**Cable entry devices**

The design of the cable entry shall be such that hot gases are not able to ignite the surrounding atmosphere following an internal explosion either through the gland or through the cable. Cable glands also have to conform to the requirements of threaded joints. 5 fully engaged threads are required but 6 are usually provided.

Cables may be brought into the flameproof enclosure directly via a cable gland. This is called 'Direct entry'. All cable entry holes must be threaded. If the gas is IIC or the cable is not filled properly, a sealing compound must be used in the gland.

Alternatively the manufacturer might provide a terminating chamber and connect the components in the flameproof enclosure with the components in the terminating chamber through bushings. This is called 'Indirect entry'. The terminating chamber is usually an Ex e enclosure.

For "Direct Entry" the cable entry system shall comply with one of the following:

- a) cable entry device in compliance with IEC 60079-1 and certified as part of the apparatus when tested with a sample of the particular type of cable;
- b) thermoplastic, thermosetting or elastomeric cable which is substantially compact and circular, has extruded bedding and the fillers, if any, are non-hygroscopic; may utilize flameproof cable entry

devices, incorporating a sealing ring selected in accordance with selection chart for cable entry devices into flameproof enclosures.

Compliance with the selection chart is not necessary if the cable gland complies with IEC 60079-1 and has been tested with a sample of specific cable to repeated ignitions of the flammable gas inside an enclosure and shows no ignition outside the enclosure.

- c) mineral-insulated metal-sheathed cable with or without plastic outer covering with appropriate flameproof cable gland complying with IEC 60079-1;
- d) flameproof sealing device (for example a sealing chamber) specified in the equipment documentation or complying with IEC 60079-1 and employing a cable gland appropriate to the cables used. The sealing device shall incorporate compound or other appropriate seals which permit stopping around individual cores. The sealing device shall be fitted at the point of entry of cables to the equipment;
- e) flameproof cable gland, specified in the equipment documentation or complying with IEC 60079-1, incorporating compound filled seals or elastomeric seals that seal around the individual cores or other equivalent sealing arrangements.

Fig 17: Selection chart for cable entry devices into flameproof enclosures for cables complying with item b)

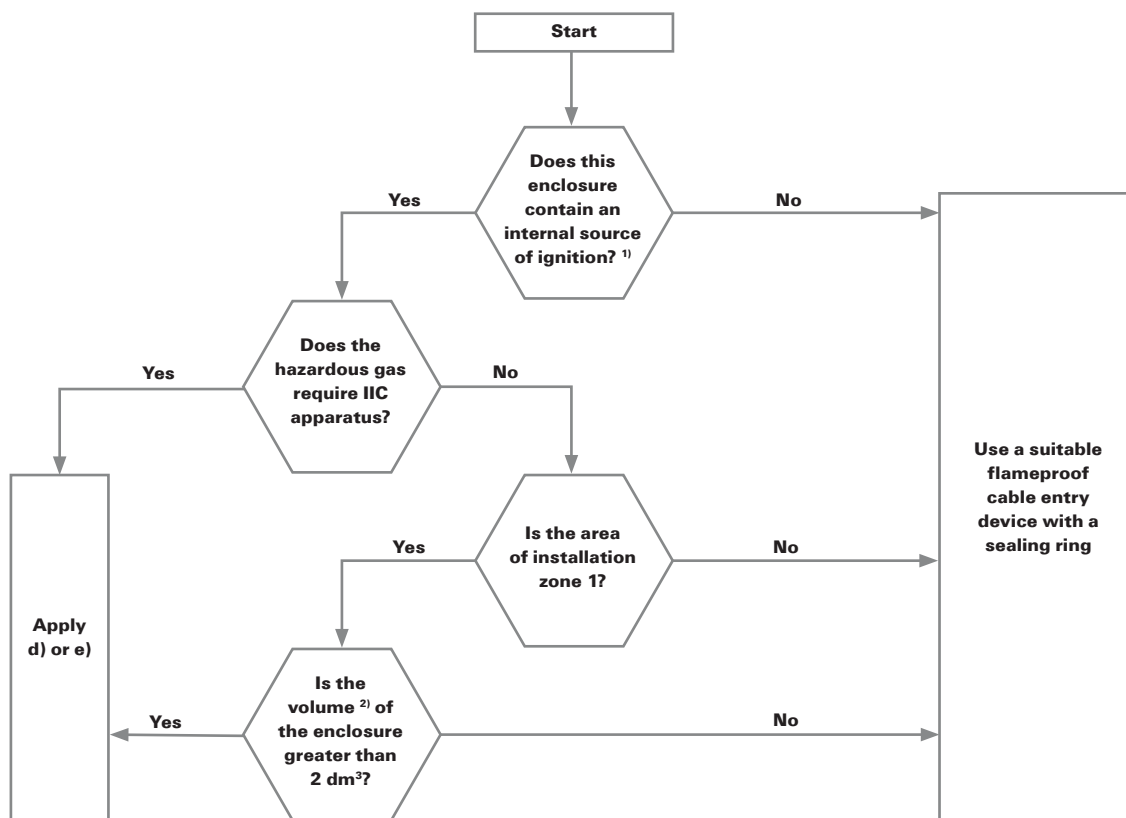

<sup>1)</sup> Internal sources of ignition include sparks or equipment temperatures occurring in normal operation which can cause ignition. An enclosure containing terminals only or an indirect entry enclosure is considered not to constitute an internal source of ignition.

<sup>2)</sup> The term 'volume' is defined in IEC 60079-1.

### 4.3.2.3

#### Intrinsic Safety "i" Basic principles

Intrinsic safety is intended for products in which the level of electrical energy circulating or stored in the product is insufficient to ignite a surrounding explosive atmosphere even under fault conditions. Because of the method by which intrinsic safety is achieved it is necessary to ensure that not only the electrical apparatus exposed to the potentially explosive atmosphere but also other electrical apparatus with which it is interconnected, is suitably constructed.

The equipment is designed according to EN 60079-11 and is suitable for gas group II, Categories 1 (ia), 2 (ib) or 3 (ic).

Typical areas of use are control and instrumentation circuits with low voltage and current.

Depending on the design and purpose, apparatus are sub-divided into two types:

**Intrinsically safe electrical apparatus** are apparatus in which all the circuits are intrinsically safe.

**Associated electrical apparatus** are apparatus which contains both energy-limited and non-energy-limited circuits and is constructed so that the non energy-limited circuits cannot adversely affect the energy-limited circuits

Associated electrical apparatus may be either:

- Electrical apparatus that has an alternative standard type of protection suitable for its use in the appropriate potentially explosive atmosphere, or
- Electrical apparatus that is not protected and therefore cannot be used within a potentially explosive atmosphere.

The limiting ignition curves for the different sub-divisions are determined with the help of a spark test apparatus. Fig 18 shows the curves for a resistive circuit. Also the stored energy in a circuit has to be taken into consideration e.g. capacitance or inductance. In the event of a short circuit, this energy could be released in addition to the energy from the associated apparatus.

Fig 18: Curves for a resistive circuit

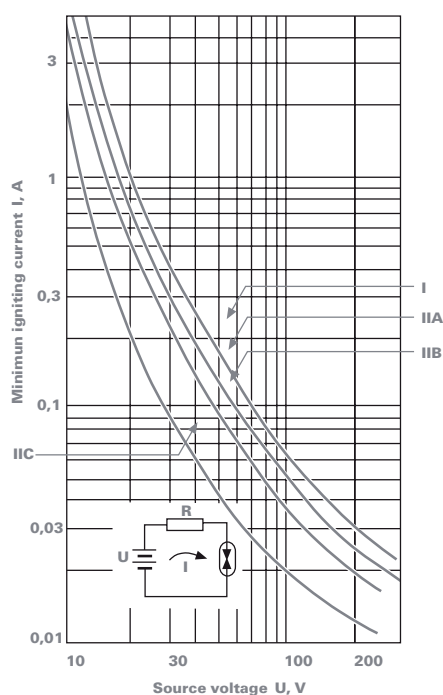

### Levels of protection

Intrinsically safe apparatus and intrinsically safe parts of associated apparatus are placed in levels of protection „ia“, „ib“ or “ic”. In the determination of level of protection “ia“, „ib“ or “ic”, failure of components, connections and separation shall be considered.

### Countable fault

A countable fault is a fault which occurs in parts of electrical apparatus conforming to the constructional requirements of IEC 60079-11.

### Level of protection ‘ia’

Intrinsically safe circuits in electrical apparatus of category ‘ia’ must not be capable of causing an ignition during normal operation when two faults occur.

- a) in normal operation and with the application of those non-countable faults which give the most onerous condition;
- b) in normal operation and with the application of one countable fault plus those non-countable faults which give the most onerous condition;

c) in normal operation and with the application of two countable faults plus those non-countable faults which give the most onerous condition.

In testing or assessing the circuits for spark ignition, the following safety factors shall be applied:

- Safety factor 1.5 for both a) and b)
- Safety factor 1.0 for c)

**Level of protection „ib“**

Intrinsically safe circuits in electrical apparatus of level of protection „ib“ shall not be capable of causing ignition in each of the following circumstances:

- a) in normal operation and with the application of those non-countable faults which give the most onerous condition;
- b) in normal operation and with the application of one countable fault plus the application of those non-countable faults which give the most onerous condition.

In testing or assessing the circuits for spark ignition, a safety factor of 1,5 shall be applied.

**Level of protection „ic“**

Intrinsically safe circuits in electrical apparatus of level of protection „ic“ shall not be capable of causing ignition in normal operation. Where distances are critical for safety, they shall meet the requirements of IEC 60079-11.

**Types of interfaces**

There are two types of interfaces namely the diode safety barrier and the galvanic isolator.

**Diode safety barrier**

This type of interface has been around for a long time. Fig 19 illustrates how the barrier is constructed. The assemblies incorporates shunt diodes or diode chains (including Zener diodes) protected by fuses or resistors or a combination of these. The fuse restricts the fault power , the zeners restrict the voltage and the resistor restricts the current.

Fig 19: Diode safety barrier

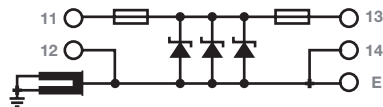

Barriers are usually described by their safety parameters 28V 116mA 240R where  $U_0=28V$  and the current limiting resistor is 240R.

Fig 20: Galvanic isolation interface

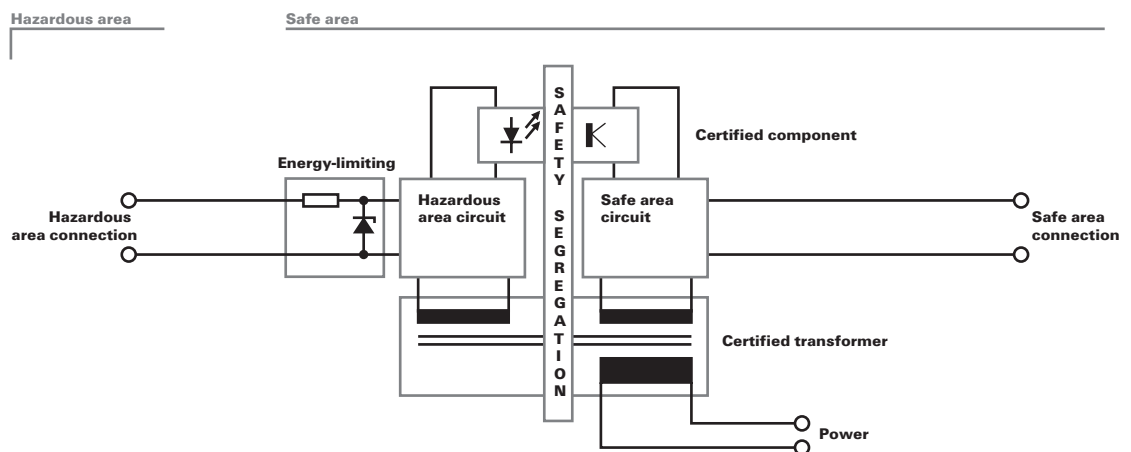

### Galvanic isolation interface

Fig 20 illustrates how the interface is constructed. The actual power limitation part of the isolator contains all the elements of the zener barrier. The power supply is via a transformer and the return signal can be via an optocoupler, transformer or relay. The hazardous area circuit has effectively been isolated from the safe area circuit.

Discussions on the pros and cons of both interfaces are still ongoing. Earthing for zener barriers is essential for it to remain safe, unlike the isolator where earthing is not a requirement. Associated apparatus with galvanic isolation between the intrinsically safe and nonintrinsically safe circuits is preferred. Table 12 list the relative merits of barriers and isolators. The significance depends on the installation.

Table 13: Relative merits of barriers and isolators

Barriers	Isolators
Simple	Complex
Versatile	Application specific
Low power dissipation	High power dissipation
Tightly controlled power supply	Wide range of power supply
High packing density	Lower packing density
Safety earth fundamental	Safety earth not essential
Reference 0V imposed on system	Isolation between signals
Isolated from earth in hazardous area (500 V)	May be earth in hazardous areas
Accuracy and linearity (0.1 %)	Lower accuracy and linearity (0.25 %)
Lower cost	Increased cost
Good frequency response	Limited frequency response
Vulnerable to lightning and other surges	Less vulnerable to lightning and other surges
Cannot be repaired	Can be repaired

Although, barriers are accepted worldwide, there are a number of countries that have additional requirements.

### Simple electrical apparatus and components

Simple electrical apparatus and components (e.g. thermocouples, photocells, junction boxes, switches, plugs and sockets, resistors, LED's) may be used in intrinsically safe systems without certification provided that they do not generate more than 1.2 V, 0.1 A, and 25 mW in the intrinsically safe system in the normal or fault conditions of the system.

Simple electrical apparatus and components should conform to all relevant requirements of the EN 60079-11. Simple electrical apparatus and components intended for use in areas where an explosive atmosphere is present continuously or for long periods (zone 0) require specific protective measures. For such apparatus, EN 60079-26 and EN 1127-1 apply in addition to EN 60079-0 and 60079-11. Special requirements e.g. for electrostatic charging of plastic materials as well as partition walls and the mounting of the apparatus are specified in this standard. According to EN 1127-1, temperatures shall not exceed 80% of the limit temperature of the temperature class.

Junction boxes and switches, however, may be awarded T6 (85°C) at a maximum ambient temperature of 40 °C because, by their nature, they do not contain heat-dissipating components.

A wide variety of "Feed Through" and "Disconnect" terminals can be fitted in Simple Apparatus enclosures. Disconnect terminals that do not require the conductors to be removed from the terminals for test and calibration purposes are particularly useful during operational conditions.

It is important that the external terminal connections maintain 3mm clearance between bare metal parts of the same IS circuit and 6mm between bare metal parts of different IS circuits. Some users prefer a Ex ia certified enclosures for IS circuits.

### Intrinsically safe electrical systems

An intrinsically safe system consists of one or more interfaces (zener barriers or isolators), one or more items of field equipment and interconnecting wiring in which any circuits intended for use in a potentially explosive atmosphere are intrinsically safe circuits.

The requirements for intrinsically safe systems are provided in EN 60079-25. The requirements for intrinsically safe concepts for fieldbus are provided in EN 60079-27.

### Individual systems

Where the user or installer buys the components separately, and builds his own system, he will be responsible to ensure that the combination of barrier and hazardous area equipment is safe. The “system design engineer” will be required to document the circuit with its interfaces, field equipment and cable parameters. According to Directive 2014/34/EU, this type of assembly is defined as an installation and as such does not require being CE marked.

If the field device(s) only include simple apparatus, the information needed to construct a safe system is included in within the certification of the barrier.

Where the field device is a certified item e.g. a temperature transmitter or a solenoid valve, then extra checks are necessary. The certificate of the field device will include its maximum input parameters which will specify one or more of the values  $U_i$ ,  $L_i$  and  $P_i$ . Compatibility must be checked by ensuring that the maximum input figures of the field device are not exceeded by the maximum output values of the chosen barrier. If the system includes more than one item of certified apparatus, then compatibility with the barrier must be checked separately. The addition of simple apparatus will not affect the compatibility, except that the system temperature might be derated.

The system will be categorised according to the least favourable components of the barrier category and the apparatus category. For example, a barrier of [Ex ia] IIC with a field device of Ex ia IIC T6 will categorise the system as Ex ia IIC T6. The addition of a field device of Ex ia IIC T4 will change the system category to Ex ia IIC T4.

Fig 21: Individual systems

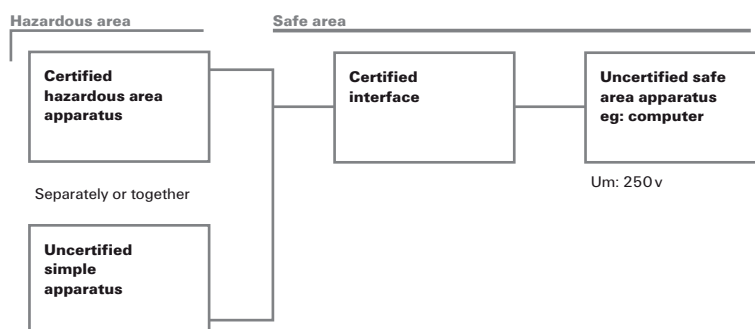

### System certificate

In some cases, the supplier of the field device might have obtained, in addition to the apparatus certificate, a system certificate that defines a number of barrier types and cable parameters of a typical system in which the device may be used. A system certificate relieves the system designer of much of the responsibility to choose the individual components, provided the defined system is suitable for the application.

If the system certificate does not include the desired arrangement, this does not mean that the arrangement is not possible, but simply that it will need to be examined separately as in previous paragraph.

Directive 2014/34/EU does not require a system certificate. However, if it is the intention of the manufacturer to put the arrangement on the market as a single unit, then the assembly will be CE marked.

### Fieldbus

The use of bus systems in hazardous areas offers the same advantages as in a safe area. The difference is the extra restrictions and cost for compliance with the hazardous area standards.

Intrinsically safe bus systems currently available are Fieldbus foundation, WorldFip, Profibus-PA and IS-78 LonWorks. Fig 24 shows a Profibus –PA system.

Fig 22: Fieldbus

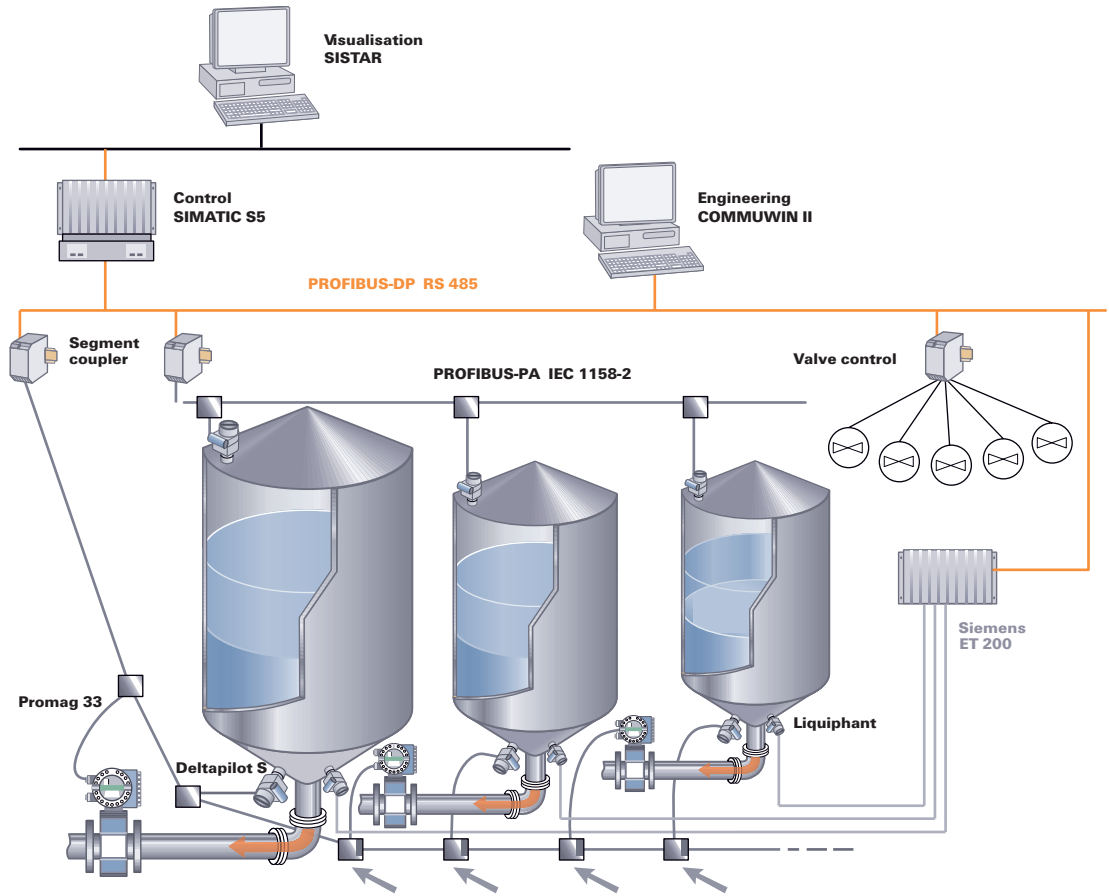

The bus systems are outside the scope of this publication except for some bus accessories. The bus systems themselves need to be terminated on both ends. An example of such a terminator is shown in fig 23.

Fig 23: Bus system

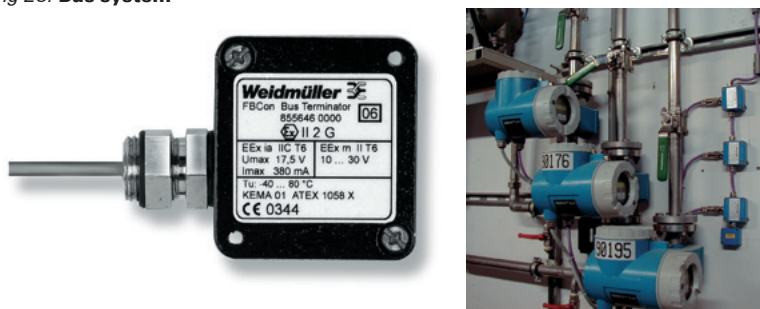

Also, in the event that IS field equipment needs servicing or replacing, it would be extremely inconvenient if the bus were interrupted. Intrinsically safe certified T-connectors are now available which allow for the field equipment to be disconnected without the bus being interrupted. They are available in single or multiple quick-connect versions see Fig 23.

### Cable entry devices

Cable entry devices in junction boxes of type of protection 'e' or 'n', which contain only intrinsically safe circuits, do not have to be certified and they do not have to maintain the 'e' or 'n' protection requirements of the enclosure. The ingress protection should be at least IP 20.

Where 'e' and 'i' circuits are combined in one enclosure, the cable entry devices must comply with the requirements for increased safety. Intrinsically safe and non-intrinsically safe circuit have to be separated by at least 50mm.

## 4.3.2.4

### Pressurisation 'p'

Pressurised apparatus achieves separation of ignition sources from explosive atmospheres by purging the atmosphere inside the apparatus with air or an inert gas and then maintaining a positive pressure inside the equipment to prevent the ingress of the explosive atmosphere during operation. Failure of the pressurisation leads to an alarm operating or the disconnection of the components having ignition capability.

The equipment is designed according to EN 60079-2. The protection px and py are suitable for equipment category 2G / equipment protection level (EPL) Gb and protection pz is suitable for equipment category 3G / EPL Gc.

Typical products are electric motors, control cabinets and gas analysers.

There are three types of pressurisation:

- Static pressurisation
- Pressurisation with continuous flow of protective gas
- Pressurisation with leakage compensation

**Static pressurisation** involves the charging of the equipment with protective gas in a non-hazardous area and maintained only by the sealing of the enclosure. There is no protective gas supply in the hazardous area. When the overpressure drops below a set value, an alarm is raised or the equipment is switched off. The apparatus can only be re-charged in the non-hazardous area.

**Pressurisation with continuous flow** of protective gas involves an initial purge cycle followed by a continuous flow of protective gas through the enclosure while maintaining a positive pressure. The system can be used where cooling is required or dilution of an internal gas release.

**Pressurisation with leakage compensation** involves an initial high purge with protective gas through the enclosure after which the outlet aperture is sealed and the protective gas supply is maintained to compensate for leakage from the enclosure. The minimum number of air changes before energisation is usually 5. Pressurising air should be drawn from a gas free area. If it is not feasible to duct air from purged equipment into a safe area, a spark and flame arrestor may be required in the outlet air duct.

## 4.3.2.5

### Equipment protection level (EPL) Ga / zone 0 equipment

EN 60079-26 specifies the particular requirements for construction, test and marking for electrical equipment that provides equipment protection level (EPL) Ga. This electrical equipment, within the operational parameters specified by the manufacturer, ensures a very high level of protection that includes rare faults related to the equipment or two faults occurring independently of each other. This standard also applies to equipment mounted across a boundary where different protection levels may be required.

It also applies to equipment installed in an area requiring a lower protection level, but electrically connected to equipment with equipment protection level (EPL) Ga (associated apparatus).

To prevent ignition hazards by the electrical circuits of the apparatus, the very high level of safety required can be obtained by:

- Single apparatus, which remains safe with two faults occurring independently from each other
- Two independent means of protection. In the event that one protection fails, an independent second one is still available.

#### **Individual concepts suitable for equipment protection level Ga or category 1 are:**

- Apparatus complying with the requirements of EN 60079-11, intrinsic safety 'ia'
- Apparatus protected by encapsulation in accordance with EN 60079-18, encapsulation ma

#### **Two independent types of protection providing EPL Gb**

Electrical equipment shall comply with the requirements of two independent types of protection that provide EPL Gb. If one type of protection fails, the other type of protection shall continue to function. The independent types of protection shall not have a common mode of failure, except as specified in this clause.

Examples:

- Torchlight with Ex d and Ex e housing and Ex ib circuit.
- Electric motor complying both with EN 60079-1, Flameproof Ex d, EN 60079-7, Increased Safety Ex e.



## 4.3.2.6

### Equipment protection level (EPL) Gc / zone 2 equipment

Equipment with equipment protection level (EPL) Gc are designed to comply with Category 3 G equipment according to Directive 2014/34/EU. They have a normal level of safety and are suitable for normal operation. Apparatus with an Equipment Protection Level of Ga or Gb may be used in an area requiring apparatus with an EPL Gc (zone 2).

The requirements for EPL Gc can be met by using the harmonised standard EN 60079-15, type of protection 'n'. EPL Gc equipment does not have to be tested by a Notified Body (ATEX only) such as BASEEFA, PTB, KEMA, etc. but the manufacturer must be able to provide evidence that the product is safe.

Control boxes may house components with individual EC Type Examination Certificates but no overall certification. The manufacturer must establish the maximum surface temperature and provide the necessary documentation.

The Ex n standard makes a distinction between apparatus that does not produce arcs, sparks or hot surface "non-sparking apparatus" an apparatus that produce arcs, sparks or hot surface in normal operation "sparking apparatus".

#### **Non-sparking apparatus**

The risk of the occurrence of arcs, sparks or hot surface during normal operation has been minimised by constructional means. The equipment is marked with "nA". Examples of apparatus are motors, luminaries, junction boxes and control boxes. Fuse terminals are considered to be non-sparking provided they are not opened under load. Fuses must be non-rewireable. When mounted in an enclosure and built to protection type Ex nA the manufacturer must ensure the internal or external surface temperature is within the T classification.

#### **Sparking apparatus**

In his case arcs, sparks or hot surfaces do occur during normal operation. The following protection concepts are allowed:

##### **Equipment with protected contacts "nC"**

These include Enclosed-break devices, Non-incendive components; Hermetically sealed devices and Sealed.

Note: The requirements for encapsulated devices are now part of the EN 60079-18 as "mc" with a transition period running (see Official Journal of the European Union).

##### **Restricted -breathing enclosures "nR"**

Restricted breathing equipment shall be limited in dissipated power such that the temperature measured on the outside does not exceed the maximum surface temperature requirements. The type of protection may be applied to enclosures containing sparking contacts but with a limitation in dissipated power such that the temperature measured on the outside of the enclosure does not exceed the external ambient temperature by more than 20 K. When applied to enclosures without sparking contacts, the only limitation is the outside temperature. This temperature shall not exceed the marked temperature class.

##### **Equipment nL (energy limited), nC (encapsulation) and nP (simplified pressurised)**

The protection concepts nL, nC (encapsulation) and nP are no longer part of the EN 60079-15. The concepts are integrated in EN 60079-11 "ic", EN 60079-18 "mc" and EN 60079-2 "pz" as equipment with the equipment protection level (EPL) Gc.

#### **Cable entry devices**

Glands must be constructed and mounted that they maintain the type of protection of the apparatus. Cable glands, whether integral or separate, shall meet the requirements of EN 60079-0.

## 4.3.2.7

### Powder Filling 'q'

Protection is provided by immersing the ignition capable parts in a fine powder, usually quartz. The arc is quenched before it can ignite the surrounding gas. Current is limited to a safe level.

The equipment is designed according to EN 60079-5 and is suitable for areas requiring equipment protection level Gb, equipment category 2G.

### 4.3.2.8

#### Oil Immersion 'o'

Protection is provided by immersing the apparatus in oil so that an explosive atmosphere cannot be ignited by the arcs and sparks generated under the oil.

The equipment is designed according to EN 60079-6 and is suitable for areas requiring equipment protection level Gb, equipment category 2G.

### 4.3.2.9

#### Encapsulation 'm'

Protection is provided by encapsulating any hot or sparking components with a material that prevents the ingress of explosive gas and cools any heat produced by the components.

The equipment is designed according to EN 60079-18 and is suitable for areas requiring equipment protection levels Ga ("ma"), Gb ("mb") and Gc ("mc"), equipment categories 1G, 2G and 3G.

## 4.4

### Installation

The EN 60079-14 "Explosive atmospheres – Part 14: Electrical installations design, selection and erection" contains the specific requirements for the design, selection and erection of electrical installations in hazardous areas associated with explosive atmospheres. Nevertheless, electrical installations in hazardous areas shall also comply with the appropriate requirements for installations in non-hazardous areas. However the requirements for non-hazardous areas are insufficient for installations in hazardous areas.

### 4.4.1

#### Selection of equipment

In order to select the appropriate electrical equipment for hazardous areas, the following information is required:

- classification of the hazardous area including the equipment protection level requirements where applicable;
- where applicable, gas, vapour or dust classification in relation to the group or subgroup of the electrical equipment;
- temperature class or ignition temperature of the gas or vapour involved;
- minimum ignition temperature of the combustible dust cloud, minimum ignition temperature of the combustible dust layer and minimum ignition energy of the combustible dust cloud;
- external influences and ambient temperature.

#### Zones

Hazardous areas are classified into zones. Zoning does not take account of the potential consequences of an explosion.

#### Relationship between Equipment protection levels (EPLs) and zones

Where only the zones are identified in the area classification documentation, then the relationship between EPL's and zones from Table 15 shall be followed.

Table 15: Equipment protection levels (EPLs) where only zones are assigned

Zone	Equipment protection levels (EPLs)
0	'Ga'
1	'Ga' or 'Gb'
2	'Ga', 'Gb' or 'Gc'
20	'Da'
21	'Da' or 'Db'
22	'Da', 'Db' or 'Dc'

Where the EPLs are identified in the area classification documentation, those requirements for selection of the equipment shall be followed.

## 4.4.2

### Protection against dangerous incendive sparking

In order to avoid the formation of sparks liable to ignite the explosive atmosphere, any contact with bare live parts other than intrinsically safe parts must be prevented.

The basic principles on which safety depends are the limitation of earth-fault currents (magnitude and/or duration) in frameworks or enclosures and the prevention of elevated potentials on equipotential bonding conductors. For electrical supply systems, other than intrinsically safe or energy-limited circuits with voltages up to 1000 V a.c./1500 V d.c. the following applies:

#### **TN System**

If a type TN power system is used, it must be the type TN-S (with separate neutral N and protective conductor PE) in the hazardous area, i.e. the neutral and the protective conductor must not be connected together, or combined in a single conductor, in the hazardous area. At any point of transition from TN-C to TN-S, the protective conductor must be connected to the equipotential bonding system in the non-hazardous area.

#### **TT systems**

If a type of system earthing TT (separate earths for power system and exposed conductive parts) is used, then it must be protected by a residual current device.

#### **IT systems**

If a type system earthing IT (neutral isolated from earth or earthed through an sufficiently high impedance) is used, an insulation monitoring device must be provided to indicate the first earth fault.

#### **Equipotential bonding**

Potential equalization is required for installations in hazardous areas. For TN, TT and IT systems, all exposed and extraneous conductive parts must be connected to the equipotential bonding system. It is also advisable to connect metal constructions, metal conduits and metal cable sheaths to the system. Connections must be permanent and secure against self-loosening. Exposed conductive parts need not be separately connected to the equipotential bonding system if they are firmly secured to and in metallic contact with structural parts or piping which are connected to the equipotential bonding system. Metallic enclosures of intrinsically safe apparatus do not have to be connected to the equipotential bonding system unless required by the apparatus documentation or to prevent accumulation of static charge.

#### **Static electricity**

In the design of electrical installations, steps must be taken to reduce to a safe level the effects of static electricity. Detailed information dealing with diameter or width of long parts and limitation of thickness of non-metallic layers can be found in 7.4 of EN 60079-0. This standard specifies the insulation resistance, the thickness and the maximum admissible sizes of non-metallic parts.

#### **Lightning protection**

In the design of electrical installations, steps must be taken to reduce to a safe level the effects of lightning (see EN 62305-3). Subclause 12.3 of EN 60079-14 gives details of lightning protection requirements for Ex 'ia' apparatus installed in locations requiring EPL 'Ga'.

#### **Electromagnetic radiation**

In the design of electrical installations, steps must be taken to reduce to a safe level the effects of electromagnetic radiation (see EN 60079-0).

#### **Cathodically protected metallic parts**

Cathodically protected metallic parts located in hazardous areas are live extraneous conductive parts which must be considered potentially dangerous (especially if equipped with an impressed current system) despite their low negative potential. No cathodic protection shall be provided for metallic parts in locations requiring EPL 'Ga' or 'Da' unless it is specially designed for this application.

#### **Ignition by optical radiation**

In the design of optical installations, steps must be taken to reduce to a safe level the effects of radiation in accordance with EN 60079-28.

### 4.4.3

#### Electrical protection

The electrical equipment and the wiring must be protected against overload and the harmful effects of short circuits and earth faults. Short-circuit and earth-fault protection devices shall be such that auto-reclosing under fault conditions is prevented. Special protective measures are required in the case of rotating electrical machinery. The over-load protective devices to be used are:

- a current-dependent, time lag protective device monitoring all three phases, set at not more than the rated current of the machine, which will operate in 2 h or less at 1,20 times the set current and will not operate within 2 h at 1,05 times the set current
- embedded temperature sensors providing direct temperature monitoring of the machine.

In no case should the automatic switch-off result in an increased safety risk. Where it might, alarming is an acceptable alternative to automatic disconnection if the alarm leads to immediate remedial action.

### 4.4.4

#### Wiring systems

Cable systems and accessories should be installed, so far as is practicable, in positions that will prevent them being exposed to mechanical damage, to corrosion or chemical influences (for example solvents), to the effects of heat and to the effects of UV radiation.

Where trunking, ducts, pipes or trenches are used to accommodate cables, precautions shall be taken to prevent the passage of flammable gases, vapours, liquids or combustible dusts from one area to another and to prevent the collection of flammable gases, vapours, liquids or combustible dusts in trenches. Cable routing must be arranged in such a way that the cables accumulate the minimum amount of dust layers whilst remaining accessible for cleaning.

Where circuits traverse a hazardous area in passing from one non-hazardous area to another, the wiring system in the hazardous area must be appropriate to the EPL requirements for the route.

Openings in walls for cables and conduits between different hazardous areas and between hazardous and non-hazardous areas must be adequately sealed, for example by means of sand seals or mortar sealing to maintain the area classification where relevant.

Where it becomes necessary to join lengths of conduit, the joint(s), in addition to being mechanically, electrically and environmentally suitable for the situation, must be made in an enclosure with a type of protection appropriate to the EPL requirements for the location, e.g. Ex e junction box, or providing the joint is not subject to mechanical stress, be 'epoxy' filled, compound-filled or sleeved with heat-shrunk tubing or cold-shrunk tubing, in accordance with the manufacturer's instructions.

Conductor connections, with the exception of those in flameproof conduit systems, intrinsically safe circuits and energy-limited circuits, must be made only by means of compression connectors, secured screw connectors, welding or brazing. Soldering is permissible if the conductors being connected are held together by suitable mechanical means and then soldered, so there is no stress on the connection. The hazardous area end of each unused core in multi-core cables shall either be connected to earth or be adequately insulated by means of terminations suitable for the type of protection. Insulation by tape alone is not permitted. Multi-stranded and, in particular, fine-stranded conductors, must be protected against separation of the strands, for example by means of cable lugs or core end sleeves, or by the type of terminal, e.g. all Weidmüller terminal types, but not by soldering alone. When using ferrules the correct crimping tool should be used.

In general only one conductor per terminal clamp is permitted. Some types of terminals are able to accommodate more than one conductor e.g. slot type and Weidmüller's W-series. Alternatively, two wires in one ferrule is also regarded as one conductor.

Where aluminium is used as the conductor material, it must be used only with suitable connections and, with the exceptions of intrinsically safe and energy-limited installations, must have a cross-sectional area of at least 16 mm<sup>2</sup>.

Where overhead wiring with uninsulated conductors provides power or communications services to equipment in a hazardous area, it must be terminated in a non-hazardous area and the service continued into the hazardous area with cable or conduit.

Cables used for fixed wiring in hazardous areas shall be appropriate for the ambient conditions in service. Cables must be sheathed with thermoplastic, thermosetting, or elastomeric material. They must be circular, compact, have extruded bedding and fillers, if any and must be non hygroscopic, or mineral insulated metal sheathed, or special, e.g. flat cables with appropriate cable glands.

For conduit systems are used national or other standards must be followed.

Unused cable entries should be fitted with stopping plugs appropriate for the type of protection. Except for intrinsic safety, they should only be removed with the aid of a tool.

## 4.4.5

### Additional requirements for flameproof enclosures 'd'

Flameproof joints must be protected against corrosion. Flameproof joints must not be painted. The use of gaskets is only permitted when specified in the documentation. Non-setting grease or anti-corrosive agents can be applied.

Non-hardening grease-bearing textile tape may also be employed outside of the joint with the following conditions:

- where the enclosure is used in conjunction with gases allocated to group IIA, the tape must be restricted to one layer surrounding all parts of the flange joint with a short overlap, new tape must be applied whenever existing tape is disturbed;
- where the enclosure is used in conjunction with gases allocated to group IIB, the gap between the joint surfaces must not exceed 0,1 mm, irrespective of the flange width. The tape must be restricted to one layer surrounding all parts of the flange joint with a short overlap. New tape must be applied whenever existing tape is disturbed;
- where the enclosure is used in conjunction with gases allocated to group IIC, the tape must not be applied.

There are three cable entry systems:

- Direct entry
- Indirect entry via e.g. Ex e enclosure
- Conduit

Fig 24: Cable entry systems

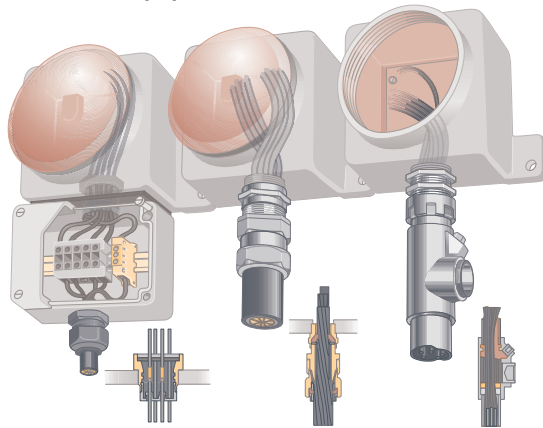

For direct entry, the cable gland selection must be made according to the selection chart for cable entry devices in 4.3.2.2.

Fig 25: A Cutaway Photograph illustrating the barrier filler and internals of Ex d Barrier gland

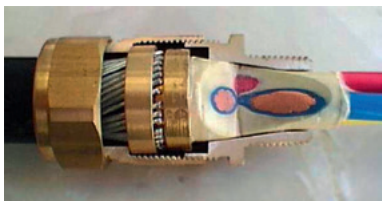

To maintain the integrity of the type of protection thread engagement must be at least five full threads. Suitable grease may be used provided it is nonsetting, non-metallic and non-combustible and any earthing between the two is maintained. Where taper threads are used, the connection shall be made wrench tight.

Conduit sealing devices must be provided, either as part of the flameproof enclosure or immediately or as close as practical to the entry to the flameproof enclosure using a minimum number of fittings.

## 4.4.6

### Additional requirements for Increased Safety 'e'

Enclosures containing bare live parts must have a degree of ingress protection of at least IP54. Threaded entries in enclosures with a wall thickness of at least 6 mm do not require a sealing washer to maintain IP 54 providing the axis of the cable entry device is perpendicular to the external surface. However, in practice enclosures are normally IP 65 or IP 66. Therefore a sealing washer is recommended.

Unused entries in the enclosure shall be sealed by blanking elements, which comply with EN 60079-0 and maintain the degree of ingress protection IP 54 or that required by the location, whichever is the higher.

Some terminals (e.g. slot types) may permit the entry of more than one conductor. Where more than one conductor is connected to the same terminal, care must be taken to ensure that each conductor is adequately clamped. Unless permitted by the manufacturer's documentation, two conductors of different cross-sectional area must not be connected into one terminal unless they are first secured with a single compression type ferrule or other method specified by the manufacturer. To avoid the risk of short-circuits between adjacent conductors in terminal blocks, the insulation of each conductor must be maintained up to the metal of the terminal.

Where single screw saddle clamps are used with a single conductor, the latter must be shaped around the screw in the form of a 'U' unless clamping of single conductors without 'U' is permitted in the documentation supplied with the equipment.

Care must be taken to ensure that the heat dissipated within the enclosure does not result in temperatures in excess of the required equipment temperature class.

This can be achieved by following the guidance given by the manufacturer relating to the permissible number of terminals, the conductor size and the maximum current, or by checking that the calculated dissipated power, using parameters specified by the manufacturer, is less than the rated maximum dissipated power of the enclosure at the temperature rating being used.

The length of the conductors inside the enclosure must not exceed the diagonal length of the enclosure as this is the basis of calculations and type tests. Additional lengths of the conductors inside the enclosure running at maximum permitted current may give rise to increased internal temperature that may exceed the temperature class. Bunching of more than 6 conductors may also give rise to high temperatures that may exceed T6 and/or damage to the insulation and should be avoided.

When cast alloy enclosures are selected, special care is necessary to avoid the danger from Bi-Metallic corrosion with dissimilar metals. This is particularly prevalent with alloy enclosures fitted with brass cable glands. The options to overcome this problem are, Nickel Plated Brass, Stainless Steel, Plastic or Glands made from a compatible alloy.

Motors supplied at varying frequency and voltage by a converter must be type tested for this duty as a unit in association with the converter specified with the descriptive documents.

## 4.5

### 4.5.1

#### Inspection and Maintenance

##### General requirements

Electrical installations in hazardous areas have features specifically designed to make them suitable

for use in such atmospheres. Directive 1999/92/EC stipulates that it is the operator's responsibility to maintain the integrity of those special features.

The operator must ensure that electrical equipment is:

- Installed and operated correctly
- Monitored on a regular basis
- Maintained with due regard to safety

The main standard for the inspection and maintenance requirements is EN 60079-17/IEC 60079-17: Electrical apparatus for explosive gas atmospheres, "Inspection and maintenance of electrical installations in hazardous areas (other than mines)". Depending on the country and industry e.g. offshore or petrol stations, additional national standards might have to be complied with.

## 4.5.1.1

### Documentation

Up-to-date information of the following items must be made available:

- Site drawings outlining the hazardous areas with the required equipment protection level (EPL)
- For gas: the required equipment group (IIA, IIB or IIC) and the temperature class
- For dust: the required equipment group (IIIA, IIIB or IIIC) and the maximum surface temperature
- Characteristics of the apparatus: rated temperatures, type of protection, IP rating, corrosion resistance
- records sufficient to enable the explosion-protected equipment to be maintained in accordance with its type of protection (see EN 60079-0) (for example list and location of apparatus, spares, technical information, manufacturer's instructions)
- copies of previous inspection records

## 4.5.1.2

### Qualification of personnel

The inspection and maintenance of installations should only be carried out by experienced personnel, whose training has included instruction on the various types of protection and installation practices, the relevant rules and regulations and on the general principles of area classification. Appropriate continuing training should be undertaken on a regular basis. Evidence of the relevant experience and training claimed must be available.

## 4.5.1.3

### Permit-to-work

A permit-to-work system is a formal written system used to control certain types of work that are potentially hazardous. A permit-to-work is a document, which specifies the work to be done and the precautions to be taken. Permits-to-work form an essential part of safe systems of work for many inspection and maintenance activities. They allow work to start only after safe procedures have been defined and they provide a clear record that all foreseeable hazards have been considered.

A permit is needed when inspection or maintenance work can only be carried out if normal safeguards are dropped or when new hazards are introduced by the work. Examples are, entry into vessels, hot work and pipeline breaking. The precise format of a work permit will vary from site to site.

## 4.5.2

### Inspections

## 4.5.2.1

### General

Before a plant is brought into service for the first time, it must be given an initial inspection. This work can be done by the operator or an outside company (third party). Note: Inspection and maintenance is covered by EN 60079-17.

To ensure that the installation is maintained in a satisfactory condition is necessary to carry out either:

- Regular periodic inspections, or
- Continuous supervision by skilled personnel

and, where necessary, maintenance must be carried out.

Following any replacement, repair, modification or adjustment, the items concerned must be inspected in accordance with the relevant items of the detailed column of tables in Appendix IV.

If, at any time, there is a change in the area classification or if any apparatus is moved from one location to another, a check must be made to ensure that the type of protection, apparatus group and temperature class, where appropriate, are suitable for the revised conditions.

## 4.5.2.2

### Types of inspection

- a. Initial inspections are used to check that the selected type of protection and its installation are appropriate. Example checklists are shown in Appendix IV.
- b. Periodic inspections are carried out on a routine basis. They may be visual or close but could lead to a further detailed inspection.

The type of equipment, manufacturer's guidance, deterioration of the apparatus, zone of use and/or the EPL-requirements of the installation area and the result of previous inspections determine the grade and the interval between periodic inspections.

The interval between periodic inspections should not exceed three years without seeking expert advice or the use of extensive inspection data.

Movable electrical apparatus are particularly prone to damage or misuse and therefore the interval between inspections should be set accordingly.

- c. Sample inspections can be visual, close or detailed. The size and composition of all samples depends on the purpose of the inspection.
- d. Continuous supervision is based on the frequent attendance, inspection, service, care and maintenance of the electrical installation by skilled personnel who have experience in the specific installation and its environment in order to maintain the explosion protection features of the installation in satisfactory condition.

Where the installation falls outside the capability of continuous supervision it will be subject to periodic inspection.

## 4.5.2.3

### Grades of inspection

- a. Visual inspections identify, without the use of access equipment or tools, those defects, such as missing bolts, which will be apparent to the eye.
- b. Close inspections include those aspects covered by a visual inspection and, in addition, identifies those defects, such as loose bolts, which will be apparent only by the use of access equipment, for example steps, (where necessary), and tools. Close inspections do not normally require the enclosure to be opened or the equipment to be de-energised.
- c. Detailed inspections include those aspects covered by a close inspection and, in addition, identifies those defects, such as loose terminations, which will only be apparent by opening the enclosure, and/or using, where necessary, tools and test equipment.

## 4.5.3

### Regular periodic inspections

To set accurately an appropriate inspection interval is not easy, but it should be fixed taking into account the expected deterioration of the equipment. Major factors effecting the deterioration of apparatus include: susceptibility to corrosion, exposure to chemicals or solvents, likelihood of accumulation of dust or dirt, likelihood of water ingress, exposure to excessive ambient temperatures, risk of mechanical damage, exposure to undue vibration, training and experience of personnel, likelihood of unauthorised modifications or adjustments, likelihood of inappropriate maintenance e.g. not in accordance with manufacturer's recommendation. Once intervals have been set, the installation can be subjected to interim sample inspections to support or modify the proposed intervals or inspection grades.

Where inspection grades and intervals have been established for similar apparatus, plants and environments, this experience can be used to determine the inspection strategy.

## 4.5.4

### Continuous supervision by skilled personnel

The objective of continuous supervision is to enable the early detection of arising faults and their subsequent repair. It makes use of existing personnel who are in attendance at the installation in the course of their normal work e.g. erection work, modifications, inspections, maintenance work, checking for faults, cleaning, control operations, functional tests and measurements. Therefore it may be possible

to dispense with the regular periodic inspection and utilise the more frequent presence of the skilled personnel to ensure the on-going integrity of the apparatus.

A technical person with executive function will be responsible for each installation and its skilled personnel. He will assess the viability of the concept and define the scope of equipment to be considered under continuous supervision. He will also determine the frequency and grade of inspection as well as the content of reporting to enable meaningful analysis of apparatus performance.

## 4.5.5

### Maintenance

Appropriate remedial measures might have to be taken following an inspection report. Care must be taken, to maintain the integrity of the type of protection provided for the apparatus; this may require consultation with the manufacturer. When necessary the area of work shall be confirmed gas free prior to commencement of work.

Maintenance requires more detailed knowledge than when the equipment is first installed. Defect parts should only be replaced by manufacturers authorised replacement parts and modifications that might invalidate the certificate or other documents should not be made.

For equipment that is manufactured and certified according to Directive 2016/34/EU, the maintenance requirements, including the need for special tools, can be found in the operating instructions supplied with each piece of equipment.

Some maintenance tasks are listed below:

Flameproof flanges should not be broken without justification. When reassembling flameproof enclosures, all joints shall be thoroughly cleaned and lightly smeared with a non-setting grease to prevent corrosion and to assist weatherproofing. Only non-metallic scrapers and non-corrosive cleaning fluids should be used to clean flanges.

The gasket on increased safety enclosures should be checked for damages and replaced if necessary. Terminals might have to be tightened. Any discoloration could indicate a rise in temperature and the development of a potential hazard. Cable glands and stopping plugs should be checked for tightness. When replacing lamps in luminaries the correct rating and type should be used, or excessive temperatures may result. If it is necessary for maintenance purposes to withdraw the equipment, the exposed conductors must be correctly terminated in an appropriate enclosure e.g. Ex e, or isolated from all sources of supply and either insulated or earthed.

## 4.5.6

### Repair

Ideally, repair work on explosion proof electrical equipment should only be carried out by the manufacturer. In this case the manufacturer will test the equipment.

Repaired products are products whose functionality has been restored following a defect without adding new features or any other modification. As this occurs after the product has been placed on the market and the product is not to be sold as a new product, the ATEX Directive 2014/34/EU does not apply. This does not preclude that national regulations of the Member States on the working environment may require some kind of assessment of the repaired product as well.

Spare parts are items intended to replace a defective or worn out part of a product previously placed and put into service on the EU market. A typical repair operation would be replacement by a spare part. The manufacturer of the spare part is normally not required to comply with Directive 2014/34/EU unless the spare part represents an equipment or component as defined by the Directive. If so, all obligations laid down in the Directive have to be fulfilled. If the manufacturer of the original spare part offers a new, different one in its place (due to technical progress, discontinued production of the old part, etc.), and it is used for the repair, the repaired product (as long as no substantial modification of the repaired product takes place) does not need to be brought into conformity at this time with Directive 2014/34/EU as the repaired product is not then placed on the market and put into service. The repairer should be aware of certain specific requirements in the relevant national legislation which may govern the repair and overhaul operation. The IEC 60079-19 gives guidance on the repair, overhaul and reclamation of certified equipment designed for use in explosive atmospheres.

# Section 5

## Combustible dusts

### 5.1

#### 5.1.1

##### Definitions and Dust characteristics

###### General

Installation in which combustible dust is handled, produced or stored should be designed, operated and maintained so that any releases of combustible dust, and consequently the extent of classified areas, are kept to a minimum.

In situations where explosive dust/air mixtures are possible, the following steps should be taken:

- Eliminate the likelihood of an explosive dust/air mixture and combustible dust layers; or
- Eliminate the likelihood of any ignition source

If this cannot be done, measures should be taken to avoid that either or both exist at the same time.

If it is not possible to eliminate the probability of an explosive dust/air mixture and a source of ignition at the same time, then explosion protective systems should be considered to halt an incipient explosion immediately or to mitigate the effects e.g. dust explosion venting systems.

However, in order to avoid unnecessary and costly plant downtime, measures would still be put in place to minimise the possibility of an ignition occurring.

The concept for area classification is similar to that used for flammable gases and vapours. However, combustible dusts, unlike flammable gases and vapours, will not necessarily be removed by ventilation or dilution after release has stopped. Very dilute and therefore non-explosive dust clouds could form, in time, thick dust layers.

Dust layers present three risks:

1. a primary explosion within a building may raise dust layers into clouds, and cause secondary explosions more damaging than the primary event. Dust layers should always be controlled to reduce this risk;
2. dust layers may be ignited by the heat flux from equipment on which the layer rests. The risk is of fire, rather than explosion, and this may be a slow process;
3. a dust layer may be raised into a cloud, ignite on a hot surface and cause an explosion. In practice, dust cloud ignition temperatures are often much higher than layer ignition temperatures.

The likelihood of a layer causing a fire can be controlled by the correct selection of equipment and effective housekeeping.

#### 5.1.2

##### Dust definitions

Electrical equipment for explosive atmospheres is divided into the following groups:

Electrical equipment intended for use in potentially explosive dust cloud or dust layer environments is divided into Group III. Electrical equipment of Group III is subdivided according to the nature of the explosive dust atmosphere for which it is intended. Group III subdivisions:

- IIIA: Combustible flyings
- IIIB: Non-conductive dust
- IIIC: Conductive dust

NOTE Equipment marked IIIB is suitable for applications requiring Group IIIA equipment. Similarly, equipment marked IIIC is suitable for applications requiring Group IIIA or Group IIIB equipment.

#### 5.1.2.1

##### Dust

Generic term including both combustible dust and combustible flyings

## 5.1.2.2

### Combustible dust

Finely divided solid particles, 500 µm or less in nominal size, which may be suspended in air, may settle out of the atmosphere under their own weight, may burn or glow in air, and may form explosive mixtures with air at atmospheric pressure and normal temperatures

## 5.1.2.3

### Conductive dust

Combustible dust with electrical resistivity equal to or less than 103 Ωm

## 5.1.2.4

### Non-Conductive dust

Combustible dust with electrical resistivity greater than 103 Ωm

## 5.1.2.5

### Combustible flyings

Solid particles, including fibres, greater than 500 µm in nominal size which may be suspended in air and could settle out of the atmosphere under their own weight.

## 5.1.2.6

### EPL Da

Equipment for explosive dust atmospheres, having a „very high“ level of protection, which is not a source of ignition in normal operation, during expected malfunctions, or during rare malfunctions.

## 5.1.2.7

### EPL Db

Equipment for explosive dust atmospheres, having a „high“ level of protection, which is not a source of ignition in normal operation or during expected malfunctions.

## 5.1.2.8

### EPL Dc

Equipment for explosive dust atmospheres, having an „enhanced“ level of protection, which is not a source of ignition in normal operation and which may have some additional protection to ensure that it remains inactive as an ignition source in the case of regular expected occurrences (for example failure of a lamp).

## 5.1.2.9

### Explosive dust atmosphere

Mixture with air, under atmospheric conditions, of flammable substances in the form of dust, fibres, or flyings which, after ignition, permits self-sustaining propagation.

## 5.1.3

### Dust characteristics

As part of the explosion risk assessment when dealing with dust, as required under Directive 1999/92/EC, three basic questions should be answered.

1. Is it flammable?
2. How easily can it be ignited?
3. How violent will the explosion be?

Some dusts will glow when in contact with a heat source but extinguish immediately when removed, other will burn fiercely and sustain a fire, which could ignite a dust cloud. If the combustibility of a product is required at high ambient temperature, the sample should be tested at the anticipated high temperature e.g. drying temperature. Sometimes there can be a big difference in the combustion behaviour.

The ease of ignition is addressed by the measurement of the minimum ignition temperature of a dust layer and dust cloud, and the minimum ignition energy.

**The ignition temperature of a dust layer** is the lowest temperature of a hot surface at which ignition occurs in a dust layer of specified thickness on a hot surface.

Combustible dusts, when deposited in heaps or layers, may under certain circumstances develop internal combustion and high temperatures. Mostly this occurs when the dust deposit or layer rests on a heated surface, which supplies the heat needed to trigger self-ignition in the dust. Such surfaces can be overheated bearings, heaters in workrooms, light bulbs, walls in dryers, etc. If disturbed and dispersed by an air blast or a mechanical action, the burning dust can easily initiate a dust explosion if brought in contact with a combustible dust cloud. Sometimes the dust in the deposit that has not yet burnt forms the dust cloud.

**The ignition temperature of a dust cloud** is the lowest temperature of the hot inner wall of a furnace at which ignition occurs in a dust cloud in air contained therein. (Note: The ignition temperature of a dust cloud may be determined by the test method given in ISO/IEC 80079-20-2) Hot surfaces capable of igniting dust clouds exist in a number of situations in industry, such as in furnaces, burners and dryers or by overheated bearings. The minimum ignition temperature is not a true constant for a given dust cloud, but depends on the geometry of the hot surface and the dynamics of the cloud. If the dust cloud is kept at a high temperature for a long period of time, e.g. in a fluidized bed, ignition can occur at temperatures below the experimentally determined minimum ignition temperature.

**The minimum ignition energy** of a dust cloud is the lowest energy value of a high-voltage capacitor discharge required to ignite the most ignitable dust/air mixture at atmospheric pressure and room temperature. Powders show quite a broad spectrum of ignition sensitivity and the vast majority need a very energetic ignition source. On plants where powders and solvents are handled, the risk assessment will normally be centred on the solvent characteristics.

The explosion violence is determined from the explosion pressure characteristics. The maximum explosion pressure, the maximum rate of pressure rise and the lower explosion limit are determined in a standard test apparatus with a content of 20 litres.

**The maximum rate of pressure rise** (dp/dt)<sub>max</sub> measured in the 20 litre-sphere is used to obtain the K<sub>st</sub>-value.

**The maximum explosion pressure** and the K<sub>st</sub>-value describe the explosion behaviour of a combustible dust in a closed system. The enclosed Table gives the characteristics of dust explosions.

Table 17: Dust characteristics

Class	K <sub>St</sub> (bar m/s)	Characteristics	Examples
St0	0	No explosion	
St1	0-200	Weak/Moderate explosion	coal dust, flour
St2	200-300	Strong explosion	epoxy resin
St3	>300	Very strong explosion	aluminum

Most process equipment is normally far too weak to withstand the pressures exerted even by only partly developed, confined dust explosions. Consequently a primary objective of fighting an explosion after it has been initiated is to prevent the build-up of destructive overpressures. Explosion protective systems such as venting, suppression and isolation can be used.

**The explosion limits** describe the range of dust concentrations in air within which an explosion is possible. Generally only the lower explosion limit is determined.

Other factors affecting dust flammability are particle size, moisture content, solvent content and temperature.

Having obtained the relevant information regarding the process, plant and material characteristics, the next step is to locate the flammable atmospheres and identify any potential sources of ignition.

## 5.2

### 5.2.1

#### Area classification

##### Definitions of zones

The concept of zones for dusts is based on the classification of areas where combustible dust may be present, either as a layer or a cloud of combustible dust, mixed with air. The area where there is a possibility of combustible dust being present is divided into 3 zones dependent on the probability of a release and the presence of the dust. Zones are defined in EN 60079-10-2

### 5.2.1.1.1

#### Definition of zone 20

A place in which an explosive atmosphere in the form of a cloud of combustible dust in air is present continuously, or for long periods or frequently.

### 5.2.1.1.2

#### Examples of typical zone 20 locations

In general, these conditions arise only inside containers, pipes, vessels, etc., i.e. usually only inside plant.

- Inside hoppers, silos etc.
- Inside cyclones and filters
- Inside dust transport systems, except some parts of belt and chain conveyors
- Inside blenders, mills, dryers, bagging equipment etc.
- Outside the containment, where bad housekeeping allows layers of dust of uncontrollable thickness to be formed

### 5.2.1.2

#### Zone 21

### 5.2.1.2.1

#### Definition of zone 21

A place in which an explosive atmosphere in the form of a cloud of combustible dust in air is likely to occur in normal operation occasionally.

### 5.2.1.2.2

#### Examples of typical zone 21 locations

This zone can, for example, include places in the immediate vicinity of e.g. powder filling and emptying points and places

- Areas outside dust containment and in the immediate vicinity of access doors subject to frequent removal or opening for operation purposes when internal explosive dust/air mixtures are present;
- Areas outside dust containment in the proximity of filling and emptying points, feed belts, sampling points, truck dump stations, belt dump over points, etc. where no measures are employed to prevent the formation of explosive dust/air mixtures;
- Areas outside dust containment where dust accumulates and where due to process operations the dust layer is likely to be disturbed and form explosive dust/air mixtures;
- Areas inside dust containment where explosive dust clouds are likely to occur (but neither continuously, nor for long periods, nor frequently) as e.g. silos (if filled and/or emptied only occasionally) and the dirty side of filters if large self-cleaning intervals are occurring.

### 5.2.1.3

#### Zone 22

### 5.2.1.3.1

#### Definition of zone 22

A place in which an explosive atmosphere in the form of a cloud of combustible dust in air is not likely to occur in normal operation but, if it does occur, will persist for a short period only.

### 5.2.1.3.2

#### Examples of typical zone 22 locations

Places in the vicinity of plant containing dust, if dust can escape at leaks and form deposits in hazardous quantities.

- Outlets from bag filter vents, because in the event of a malfunction there can be emission of explosive dust/air mixtures;
- Locations near equipment that has to be opened at infrequent intervals or equipment that from experience can easily form leaks where, due to pressure above atmospheric, dust will be blown out: pneumatic equipment, flexible connections that can become damaged, etc.
- Storage of bags containing dusty product. Failure of bags can occur during handling, causing dust leakage.



Table 18: Designation of zones depending on presence of combustible dust

Presence of combustible dust	Resulting zone classification
Continuous presence of dust cloud	20
Primary grade of release	21
Secondary grade of release	22

## 5.2.2.2

### Extent of zones

The extent of a zone for explosive dust atmospheres is defined as the distance in any direction from the edge of a source of dust release to the point where the hazard associated with that zone is considered to exist no longer. Consideration should be given to the fact that fine dust can be carried upwards from a source of release by air movement within a building. The extent of an area formed by a source of release also depends upon several dust parameters such as dust amounts, flow rate, particle size, product moisture content etc. In case of areas outside buildings (open air) the boundary of the zone can be reduced because of weather effects such as wind, rain, etc.

## 5.2.2.3

### Housekeeping

Inside a dust containment where powders are handled or processed, layers of dust of uncontrolled thickness often cannot be prevented because they are an integral part of the process. In principle, the thickness of dust layers outside equipment can be limited. The limitation is by housekeeping and during the consideration of sources of release it is essential to agree the nature of the housekeeping arrangements for the plant. The frequency of cleaning alone is not enough to determine whether a layer contains sufficient dust to control these risks. The rate of deposition of the dust has an effect; for example, a secondary grade of release with a high deposition rate may create a dangerous layer much more quickly than a primary grade with a lower deposition rate. The effect of cleaning is therefore more important than frequency.

Three levels of housekeeping can be described:

1. **Good:** dust layers are kept to negligible thickness, or are non-existent, irrespective of the grade of release. In this case the risk of the occurrence of explosive dust clouds from layers and the risk of fire due to layers has been removed;
2. **Fair:** dust layers are not negligible but are short lived (e.g. less than 1 shift). Depending on the thermal stability of the dust, and the surface temperature of the equipment, the dust may be removed before any fire can start.
3. **Poor:** dust layers are not negligible and persist for more than e.g. 1 shift. The fire risk may be significant.

When a planned level of housekeeping is not maintained, additional fire and explosion risks are created. Some equipment may no longer be suitable.

## 5.2.2.4

### Removal of dust deposits

Hazardous dust deposits can be avoided by regular cleaning of work and technical rooms. A proven approach is the use of cleaning schedules prescribing the nature, extent and frequency of cleaning and the responsibilities of those concerned. These instructions can be tailored to the specific case. Particular attention should be paid to (e.g. elevated) surfaces which are difficult to inspect or reach, where considerable amounts of dust may be deposited over time. Where appreciable quantities of dust are released as a result of operational malfunctions (e.g. damage to or bursting of containers, leakage) additional steps should be taken to remove the dust deposits with as little delay as possible. Wet cleaning and exhausting of dust deposits (using central extraction systems or mobile industrial vacuum cleaners containing no ignition sources) has proved to have safety advantages. Cleaning processes in which dust is raised into suspension should be avoided. It should be borne in mind that wet cleaning can create extra problems of disposal. Where light-metal dusts are collected in wet scrubbers, it must be borne in mind that hydrogen may be formed. The practice of blowing away deposited dust should be avoided.

The cleaning arrangements can be laid down as part of operational instructions for working with flammable substances.

Note: Only vacuum cleaners containing no ignition sources may be used for flammable dusts.

## 5.3

### Dust explosion protection measures

Combustible dusts and fibres can be ignited by several types of ignition sources such as:

- hot surfaces
- flames and hot gases
- mechanically generated sparks
- electrical apparatus
- stray electrical currents, cathodic corrosion protection
- static electricity
- lightning
- electromagnetic fields in the frequency range from 9 kHz to 300 GHz
- electromagnetic radiation in the frequency range from 300 GHz to  $3 \times 10^6$  GHz or
- wavelength range from  $1000\mu\text{m}$  to  $0.1 \mu\text{m}$  (optical spectrum)
- ionising radiation
- ultrasonics
- adiabatic compression, shock waves, gas flows
- chemical reactions

In order to avoid effective ignition sources or mitigate their effect, a number of explosion protection measures can be applied.

## 5.3.1

### Protective systems

„Explosion protection measures“ means all measures that

- prevent the formation of hazardous explosive atmospheres,
- avoid the ignition of hazardous explosive atmospheres or
- mitigate the effects of explosions so as to ensure the health and safety of workers.

## 5.3.1.1

### Explosion resistant (containment)

An explosion resistant design ensures that the explosion is contained inside the vessel. This also means that connecting and isolating equipment have to meet the same requirements.

Two types of design exist:

**Explosion pressure resistant** vessels or apparatus are able to withstand the expected pressure of the explosion without permanent deformation.

**Explosion pressure shock resistant** vessels or apparatus are able to withstand the expected explosion pressure without destruction but may be permanently deformed.

## 5.3.1.2

### Venting system

An explosion vent is a relief device that ruptures at a predetermined pressure to allow the fireball and explosive pressure to vent into a safe area. The vents fit into the walls of a process volume and are available in a variety of sizes, configurations and materials to ensure fast, reliable operation in an explosion situation. Typically, vents are installed in conjunction with an isolation system.

## 5.3.1.3

### Suppression system

In a matter of milliseconds, an explosion suppression system detects the buildup of pressure in an explosion and discharges an explosion suppressant into the enclosed space before destructive pressures are created.

The suppressant works in two ways:

**Chemically**, by interfering with the explosion's reaction, and

**Thermally**, by removing heat from the deflagration's flame front and thereby lowering its temperature below that needed to support combustion.

The explosion suppressant also creates a barrier between the combustible particles to prevent the further transfer of heat.

## 5.3.1.4

### Isolation system

Isolation Systems are designed to detect incipient explosions and react instantly to keep the deflagration from spreading to unprotected areas or interconnected equipment.

**The Chemical Type Isolation** method discharges an explosion suppressant into the pipeline to suppress the fireball and prevent it from reaching other plant areas or equipment.

**The Mechanical Type Isolation** method produces the same results by triggering the release of a high speed valve that forms a mechanical barrier in the pipeline.

## 5.3.2

### Protection by enclosures – t

The type of protection “Protection by enclosures” is based on limiting the maximum surface temperature of the enclosure and restricting the ingress of dust by using dust-tight or dust-protected enclosures. The equipment inside the enclosure can be sparking or at a higher temperature than the surface temperature. Only when gas and dust are present at the same time, will the type of enclosure and/or content be restricted. The term enclosure is used for boxes, motor housings, luminaries, etc.

The degrees of dust protection are defined as:

**Dust-tight enclosure:** An enclosure, which prevents the ingress of all observable dust particles. (IP 6X). Usable for Zone 20 (category 1D), Zone 21 (category 2D) and even Zone 22 (in the present of conductive dust) (category 3D).

**Dust-protected enclosure:** An enclosure, in which the ingress of dust is not totally prevented, but dust does not enter to interfere with the safe in sufficient quantities to operation of the equipment. Dust shall not accumulate in a position within the enclosure where it is liable to cause an ignition hazard. (IP 5X). for Zone Zone 22 (in the present of non-conductive dust) (category 3D)

The requirement for category 1D and 2D enclosure and gasket materials is basically the same as for increased safety enclosures. For electrical equipment of the category 3D is sufficient, if plastic materials have a TI-value, which is at least 10 K higher, as the temperature in the hottest place of the enclosure. However the demands on non-metallic materials with regard to static electricity are more onerous. Propagating brush discharges have to be avoided and this can be achieved by using plastic material with one or more of the following characteristics:

- Insulation resistance  $\leq 10^9 \Omega$
- Breakdown voltage  $\leq 4 \text{ kV}$
- Thickness  $\geq 8 \text{ mm}$  of the external insulation on metal parts

Note: This is also valid for painting

**Cable entries** conform to the requirements of EN60079-0. It should be noted that in the case of dust explosion protection for category 1D and 2D equipment, IP6X is required and for category 3D equipment, IP 5X.

**Marking** in accordance with Directive 2014/34/EU should include

- Manufacturer’s name and address (Logo)
- Type identification
- Serial number (if required)
- Year of manufacture
- Ex
- Equipment group II
- “D” for dust
- Category 1,2 or 3
- Certificate number (if required)
- Maximum surface temperature
- IP rating
- Relevant electrical information
- CE mark

Label in fig 29 is an example of the marking for a junction box. The assembly has been certified for gas as well as for dust atmospheres. However, when used in an environment where gas and dust is present

at the same time, additional precautions must be taken before use e.g. minimum IP rating for Ex e is IP54, but for zone 21 in a dust atmosphere, IP 6X is required. Therefore the minimum IP rating is IP 64.

Fig 26: Example of the marking for a junction box

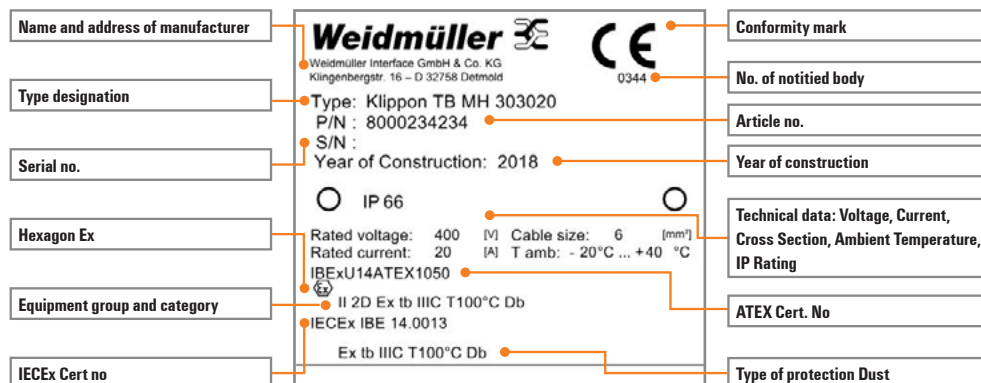

### 5.3.3

#### Other protection concepts

Prior to the introduction of the ATEX directive in 2003 it was commonplace to use equipment that was classified for Gas environments in a Dust environment. With the introduction of ATEX this is no longer possible and equipment introduced into a Potentially Explosive Dust environment must be specifically approved for such use.

The zones of use are listed in Table 19.

Table 19: Other types of protection

Protection Type		Zones of use
Flameproof enclosure	Ex d	21 & 22
Increased Safety	Ex e	21 & 22
Reduced Risk	Ex n	22
Intrinsic Safety	Ex i	ia: 20, 21, 22 ib: 21, 22
Pressurisation	Ex p	21 & 22
Encapsulation	EX m	21 & 22
Oil Emersion	Ex o	21 & 22
Powder Filling	Ex q	21 & 22

Additional precautions have to be taken when using such equipment in a dust atmosphere. Flameproof equipment would have to be purchased specifically for dust atmospheres, as the normal IP rating might not be sufficient. Cabling can follow conventional practice for flameproof equipment but if flammable gas is not an issue, Ex e cable glands with an Ingress Protection level of IP 65 will be suitable.

Ex e or Ex n apparatus should be purchased with the appropriate ingress protection. Intrinsically safe barriers certified for flammable gasses can be used in dust atmospheres. When used in dust containment, barriers of the type 'ia' and certified for gas group IIC should be used.

In accordance with ATEX 95, apparatus with two independent methods of protection can also be used in zone 20. Example: t certified enclosure, IP 6X with iD circuit or pD apparatus with t certified enclosure.

### 5.3.7

#### Selection of apparatus

When selecting apparatus for use in dust atmospheres, the following information should be available:

- Zones equipment will be used in
- Characteristics of the dust present, such as:
  - Ignition temperature of 5 mm dust layer
  - Ignition temperature of the dust cloud

The equipment category suitable for the zones is selected in accordance with table 20.

Table 20: Type of dust

Type of dust	Zone 20	Zone 21	Zone 22
Conductive	Cat 1D Excessive and uncontrollable dust layers. Test under simulated working conditions	Cat 1D or Cat 2D	Cat 1D or Cat 2D
Non conductive	Cat 1D Excessive and uncontrollable dust layers. Test under simulated working conditions	Cat 1D or Cat 2D	Cat 1D or Cat 2D or Cat 3D

The maximum surface temperature for apparatus operating in any zone is calculated by deducting a safety margin from the minimum ignition temperatures of a dust cloud and a dust layer up to 5 mm thick.

1. Maximum permissible surface temperature in case of dust clouds

$$T_{\max} = \frac{2}{3} T_{\text{cloud}}$$

( $T_{\text{cloud}}$  is the ignition temperature of a cloud of dust)

2. Maximum permissible surface temperature in case of dust layer (max 5 mm)

$$T_{\max} = T_{5\text{ mm}} - 75\text{K}$$

( $T_{5\text{ mm}}$  is the ignition temperature of a 5 mm dust layer)

Example: Milk powder, skimmed spray dried

$$T_{5\text{ mm}} = 340\text{ °C} \text{ and } T_{\text{cloud}} = 540\text{ °C}$$

$$T_{\max(1)} = \frac{2}{3} \times 540\text{ °C} = 360\text{ °C}$$

$$T_{\max(2)} = 340\text{ °C} - 75\text{K} = 265\text{ °C}$$

According to this, the maximum surface temperature of the apparatus must not exceed 265 °C. Where it is possible that dust layers in excess of 5 mm up to 50 mm are formed on top of the apparatus, the maximum permissible surface temperature must be reduced in accordance with the graph in fig 30.

Fig 27: Reduction in maximum permissible surface temperature for increasing depth of dust layers

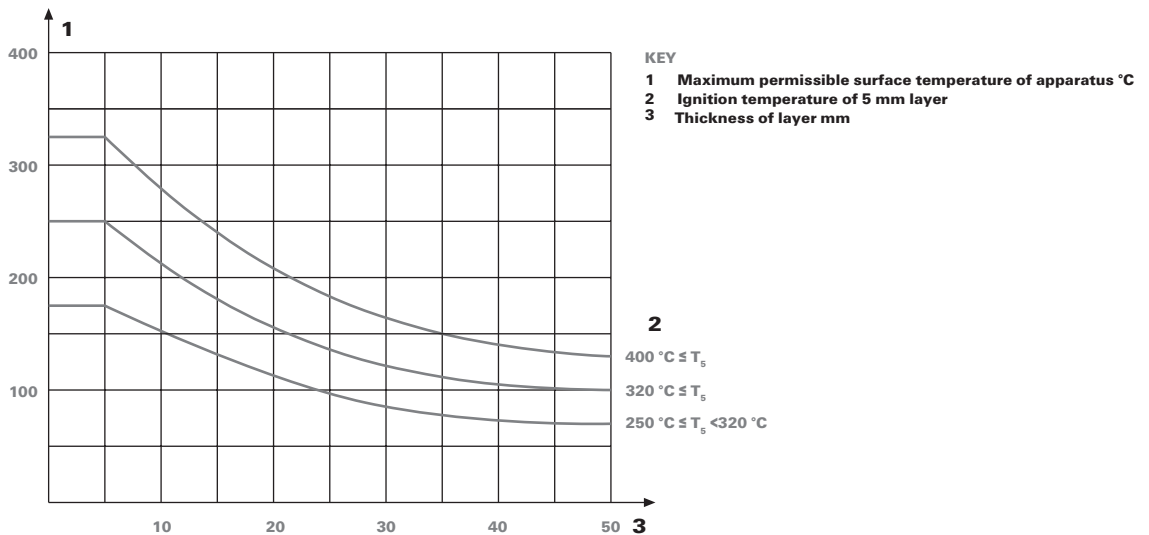

In our example, the ignition temperature of the 5 mm layer is between 320 °C and 400 °C, therefore the middle curve (320 °C) should be used. For a layer, say 20 mm thick, the maximum surface temperature derived from fig 30 is:

$$T_{\max} = 160\text{ °C}$$

Where it cannot be avoided that a dust layer in excess of 50 mm is formed on top of the apparatus, or around the sides, or where the apparatus is totally submerged in the dust (typical zone 20 application), a much lower surface temperature may be required. This should be investigated under simulated working conditions.

The special requirements for zone 20 can be met by a system of power limitation, with or without temperature control.

Power engineering apparatus e.g. motors, luminaries, plug and sockets, shall wherever practicable be placed outside zone 20 areas or if used at all, be submitted for special testing.

## 5.4

### Installations

The installation requirements are similar to those in areas free of combustible dust. Installations in dust atmospheres shall be designed and apparatus installed with a view to providing ease of access for cleaning.

## 5.4.1

### Types of cables

All common types of cable can be used if they are drawn into screwed, solid drawn or seamed welded conduit. It is also possible to use cables that are inherently protected against mechanical damage and are impervious to dust e.g.

- Thermoplastic or elastomer insulated, screened or armoured cable with a PVC, PCP, or similar sheath overall
- Cables enclosed in a seamless aluminium sheath with or without armour
- Mineral insulated cables with metal sheath
- Cables externally provided with protection or where there is no danger of mechanical damage, thermoplastic or elastomer insulated with a PVC, PCP or similar overall sheath are allowed.

**Note: The current inside cables may need to be derated to limit surface temperature**

## 5.4.2

### Cable installation

- Cable runs shall be arranged so that they are not exposed to the friction effects and build up of electrostatic charge due to the passage of dust.
- Cable runs shall be arranged insofar possible that they collect the minimum amount of dust and are accessible for cleaning. Wherever possible, cables that are not associated with the hazardous areas shall not pass through them.
- Where layers of dust are liable to form on cables and impair the free circulation of air, consideration shall be given to reduce the current carrying capacity of the cables, especially if low ignition temperature dust is present.
- When cables pass through a floor, partition or a ceiling that forms a dust barrier the hole that is provided shall be made good to prevent the passage or collection of combustible dust.
- When metal conduit is used, care should be taken to ensure that no damage might occur to the connecting points, that they are dustproof, that the dust proofing of connected equipment is maintained, and that they are included in the potential equalisation.
- Cable should not be led thru potentially explosive dust areas, if they do not stand with these ranges in connection.

## 5.4.3

### Cable entry devices

The requirements for the entries in category 1D and 2D dust-explosion protection equipment are basically the same as for increased safety. The only difference is the IP rating, IP 6X for Zone 20 and Zone 21, instead of IP54 for Zone 1 and Zone 2

## 5.5

### Inspection and maintenance

## 5.5.1

### Inspection

Inspection criteria are still undergoing extensive revision. The procedures are similar to those for gas atmospheres but special consideration should be given to:

- Presence of accumulations of dust on the outside of apparatus is to be noted and recorded. Excessive dust layers will cause apparatus to overheat, which may lead to premature failure
- Presence of any dust within the equipment and enclosures when carrying out detailed inspections. Note and record presence of dust

The inspection tables in Appendix V represent current views but may be subject to future amendments. The inspection grades used are the same as for gas atmospheres.

## 5.5.2

### Maintenance

Maintenance procedures follow very closely those for gas atmospheres.

The principle requirement is to ensure that no excessive accumulations of dust remain on the electrical equipment or is able to cause friction in mechanical equipment.

Where significant dust layers are allowed to settle and remain for a long period of time this could lead to serious deterioration of the equipment or could become a combustible atmosphere when disturbed.

## 5.5.3

### Repair

Repair procedures follow those for gas atmospheres.

## Section 6

### Explosion Protection in North America

#### 6.1

##### Overview of Regulations in North America (USA and Canada)

North American installation requirements for hazardous areas, the well known “Class-Division” schemes, have historically differed from their IEC “Zone” counterparts. The growing trend in North America, however, toward the use of IEC equipment has led to the introduction of parallel hazardous area codes that allow for IEC-recognized protection techniques and wiring methods. The result is simpler and lower-cost electrical installations that are easier to maintain and modify.

The choice of classification scheme is not simply a matter of whether to name an area a Zone rather than a Division. Rather, each scheme carries with it a whole approach to design and execution – a philosophy incorporating a set of techniques, wiring methods, and even aesthetics. In addition, because North American installations may now be executed according to one scheme or the other, particularly in the USA, and both may even appear in the same facility, the requirements must now provide for a hybrid approach. For example, they must answer questions such as, may a Division touch a Zone? Is equipment marked for a Division permitted in a Zone, or vice-versa?

In the USA, electrical requirements are set forth in the National Electrical Code (NEC). The NEC itself is not a law but a standard, which jurisdictions, i.e., counties and states, typically adopt by reference and modify according to local preferences. The NEC is updated on a three-year cycle, the most recent edition being 2008. The edition in force in any jurisdiction is left to the discretion of the jurisdiction, and is not always the most recent. Thus, there is not strict uniformity among jurisdictions, because no single authority has national enforcement oversight.

In Canada, electrical requirements are set forth in the Canadian Electrical Code (CEC). The Canadian code cycle is also three years; the most recent edition is 2009.

Both the NEC and CEC hazardous location requirements differ from the European in a number of ways, particularly in the classification schemes for hazardous areas and in the types of protection allowed. In the traditional North American schemes, there are two classification levels, a Class designation of either I, II, or III, identifying the type of hazardous substance encountered, and a Division or Zone designation, identifying the level of hazard. The IEC scheme provides only a single Zone designation, 0, 1, or 2 for gases and 20, 21, or 22 for dusts, which indicates both the type of substance and the level of hazard.

There also exist differences between the NEC and the CEC. For example, the NEC recognizes both Class-Division and Class-Zone for Class I. The CEC recognizes only Class-Zone for new Class I installations, although existing Class I installations using Divisions are allowed to continue doing so. As another example, the Zone designations 20, 21, and 22, recognized in the NEC as an alternative to Classes II and III, have no provision in the CEC.

Since the North American Zone schemes and their associated equipment requirements are identical to those in the IEC, this section will not recapitulate discussions found elsewhere in this guide. Rather, this section will address two new subjects primarily:

1. The traditional Class-Division scheme used in North America (primary in the USA and secondary in Canada), and
2. The hybrid requirements that recognize and reconcile two schemes in current use.

#### 6.1.1

##### USA: the National Electrical Code (NEC)

The NEC provides for the classification of hazardous locations according to Class-Division or according to Class-Zone, and for the use of both schemes in a single facility.

In the USA, the NEC includes seven articles regarding hazardous locations in general:

**Table 21: NEC articles covering hazardous locations**

Article 500	Hazardous (Classified) Locations, Classes I, II, and III, Divisions 1 and 2
Article 501	Class I Locations
Article 502	Class II Locations
Article 503	Class III Locations
Article 504	Intrinsically Safe Systems
Article 505	Class I, Zone 0, 1, and 2 Locations
Article 506	Zone 20, 21, and 22 Locations for Combustible Dusts or Ignitable Fibers/Flyings

In addition to the Articles listed above, Articles 510 through 516 contain the requirements in for specific types of facilities such as commercial garages, service stations, bulk storage plants, spray application, and aircraft hangars.

## 6.1.2

### Canada: the Canadian Electrical Code (CEC)

The CEC provides for classifying Class I locations according to Class-Zone and Classes II and III locations according to Class-Division. The Class-Division scheme for Class I locations is also preserved in an appendix for facilities historically employing that scheme. Interestingly, unlike the NEC and the IEC, the CEC contains no provision for the two-digit Zone designations indicating dust-bearing atmospheres.

In Canada, Section 18 of the Canadian Electrical Code (CEC) contains the numerous Rules regarding hazardous locations in general:

**Table 22: CEC rules covering hazardous locations**

Rule 18-000	Classification of Hazardous Locations
Rule 18-090	Class I, Zone 0 Locations
Rule 18-100	Class I, Zones 1 and 2 Locations
Rule 18-200	Class II, Divisions 1 and 2 Locations
Rule 18-300	Class III, Divisions 1 and 2 Locations

In addition, Section 20 contains the requirements for specific types of facilities such as commercial garages, service stations, bulk storage plants, spray application, and aircraft hangars.

## 6.2

### Class I, II, and III Hazardous Locations

Locations are classified according to the properties of vapors, liquids, gases, dusts, or fibres/flyings that may be present, and the likelihood that a flammable or combustible concentration or quantity is present.

### 6.2.1

#### Class I Locations

Class I locations are those in which flammable gases, flammable liquid-produced vapors, or combustible liquid-produced vapors are or may be present in the air in quantities sufficient to produce explosive or ignitable mixtures.

#### 6.2.1.1

##### Class I, Division 1 Locations

Class I, Division 1 locations are those where

1. Ignitable concentrations of flammable gases, flammable liquid-produced vapors, or combustible liquid-produced vapors can exist under normal operating conditions, or
2. Ignitable concentrations of such gases or vapors above their flash points may exist frequently because of repair or maintenance operations or because of leakage, or
3. Breakdown or faulty operation of equipment or processes might release ignitable concentrations of such gases or vapors and might also cause simultaneous failure of electrical equipment in such a way as to directly cause the electrical equipment to become a source of ignition.

#### 6.2.1.2

##### Class I, Division 2 Locations

Class I, Division 2 locations are those where

1. In which volatile flammable gases, flammable liquid-produced vapors, or combustible liquid-produced vapors are handled, processed, or used, but in which the liquids, vapors, or gases will normally be confined within closed containers or closed systems from which they can escape only in case of accidental rupture or breakdown of such containers or systems or in case of abnormal operation of equipment, or
2. In which ignitable concentrations of such gases or vapors are normally prevented by positive mechanical ventilation and which might become hazardous through failure or abnormal operation of the ventilating equipment, or
3. That is adjacent to a Class I, Division 1 location, and to which ignitable concentrations of such gases or vapors above their flash points might occasionally be communicated unless such communication is prevented by adequate positive-pressure ventilation from a source of clean air and effective safeguards against ventilation failure are provided.

## 6.2.2

### Class II Locations

Class II locations are those that are hazardous because of the presence of combustible dust.

### 6.2.2.1

#### Class II, Division 1 Locations

Class II, Division 1 locations are those where

1. Combustible dust is in the air under normal operating conditions in quantities sufficient to produce explosive or ignitable mixtures, or
2. Mechanical failure or abnormal operation of machinery or equipment might cause such explosive or ignitable mixtures to be produced, and might also provide a source of ignition through simultaneous failure of electrical equipment, through operation of protection devices, or from other causes, or
3. Group E combustible dusts may be present in quantities sufficient to be hazardous.

### 6.2.2.2

#### Class II, Division 2 Locations

Class II, Division 2 locations are those where

1. Combustible dust due to abnormal operations may be present in the air in quantities sufficient to produce explosive or ignitable mixtures; or
2. Combustible dust accumulations are present but are normally insufficient to interfere with the normal operation of electrical equipment or other apparatus, but could as a result of infrequent malfunctioning of handling or processing equipment become suspended in the air; or
3. Combustible accumulations on, in, or in the vicinity of the electrical equipment could be sufficient to interfere with the safe dissipation of heat from electrical equipment, or could be ignitable by abnormal operation or failure of electrical equipment.

## 6.2.3

### Class III Locations

Class III locations are those that are hazardous because of the presence of easily ignitable fibers or materials producing combustible flyings are handled, manufactured, or used, but in which such fibers/flyings are not likely to be in suspension in the air in quantities sufficient to produce ignitable mixtures.

### 6.2.3.1

#### Class III, Division 1 Locations

Class III, Division 1 locations are those where easily ignitable fibres/flyings are handled, manufactured, or used.

### 6.2.3.2

#### Class III, Division 2 Locations

Class III, Division 2 locations are those where easily ignitable fibres are stored or handled other than in the process of manufacture.

## 6.3

### Protection Techniques

Most of the protection techniques available in the Zone scheme are also available in the Division scheme, but the indication of a Zone protection technique does not indicate suitability in a Division.

Equipment in general-purpose enclosures may be installed in Division 2 locations provided the equipment does not constitute a source of ignition under normal operating conditions. Typically, UL-listed rail-mounted terminals fitted in a type 4X enclosure may be installed in a Division 2 location.

## 6.3.1

### Protection Techniques under Class-Division

Table 23: Protection Techniques under Class-Division

Division	Class		
	I	II	III
1	Explosion-proof; Intrinsic safety; Purged/pressurized (Type X or Y);	Dust-ignition proof; Intrinsic safety; Purged/pressurized;	Dust tight; Intrinsic safety; Hermetically sealed; Purged/pressurized;
2	Hermetically sealed; Non-incendive circuits; Non-incendive components; Non-incendive equipment; Non-sparking devices; Oil immersion; Purged/pressurized (Type Z); Any Class I, Division 1 method; Any Class I, Zone 0, 1 or 2 method	Dust tight; Hermetically sealed; Non-incendive circuits; Non-incendive components; Non-incendive equipment; Non-sparking devices; Any Class II, Division 1 method	Non-incendive circuits; Non-incendive components; Non-incendive equipment; Non-sparking devices; Any Class III, Division 1 method

## 6.3.2

### Enclosure Types to IP Designations

The following table shows the conversion from common enclosure Types (sometimes referred to as NEMA Types) to the corresponding IP designation.

Table 24: Enclosure Types to IP Designations

Type	Meaning	IP Designation	Remarks
1	General purpose	IP10	The enclosure Type implies materials and methods of construction as well as function. The IP designation indicates a degree of ingress protection only, without reference to materials, methods, or environmental suitability. It is therefore not possible to convert directly from IP designation to enclosure Type.
3R	Rainproof	IP14	
4 and 4X	Watertight	IP56	
6P	Submersible	IP67	
7	Class I Explosion-proof	-	
9	Class II Explosion-proof	-	
12	Dusttight	IP52	
13	Oiltight	IP54	Note that Types 7 and 9 explosion-proof enclosures have no corresponding IP designation.

## 6.4

### Equipment

Suitability of equipment is determined by any of the following (NEC 500.8):

1. Equipment listing or labeling
2. Evidence of equipment evaluation from a qualified testing laboratory or inspection agency concerned with product evaluation
3. Evidence acceptable to the authority having jurisdiction, such as a manufacturer's self-evaluation or the owner's engineering judgement

Evidence of suitability may include certificates demonstrating compliance with applicable equipment standards, indicating special conditions of use, and other pertinent information.

## 6.4.1

### Material Groups for Class-Division

Material groups in the NEC are identified by a letter code and are different from the groups in the European system. NEC material groups are shown in the table below followed by a typical material from that Group. Class III does not have material groups. In addition, the NEC allows equipment to be used only for those groups for which it is explicitly labeled. (The IEC material groups imply suitability for less stringent groups.)

Table 25: Material Groups for Class-Division

CLASS I	CLASS II	CLASS III
D (Propane)	E (Metal dusts)	No material groups.
C (Ethylene)	F (Coal dusts)	
B (Hydrogen)	G (Grain dust)	
A (Acetylene)		

## 6.4.2

### Temperature Ratings for Class-Division

Equipment marked for Classes I and II is not permitted to have any exposed surface that operates at a temperature above the ignition temperature of the hazardous substance. Equipment is marked with a T-Code indicating its maximum surface temperature. Lower maximum temperatures and higher T-Codes indicate more stringent requirements.

Table 26: Temperature Ratings for Class-Division

Maximum Temperature	Temperature Class (T-Code)
450 °C (842 °F)	T1
300 °C (572 °F)	T2
280 °C (536 °F)	T2A
260 °C (500 °F)	T2B
230 °C (446 °F)	T2C
215 °C (419 °F)	T2D
200 °C (392 °F)	T3
180 °C (356 °F)	T3A
165 °C (329 °F)	T3B
160 °C (320 °F)	T3C
135 °C (275 °F)	T4
120 °C (248 °F)	T4A
100 °C (212 °F)	T5
85 °C (185 °F)	T6

Class III does not have T-Codes. For Class III, the maximum surface temperatures under operating conditions shall not exceed 165°C (329°F) for equipment that is not subject to overloading, and 120 °C (248 °F) for equipment (such as motors or power transformers) that may be overloaded.

## 6.4.3

### Equipment Marking

Equipment is to be marked according to its suitability for use in the Class and Division or Class and Zone where it is installed. In addition, Division equipment may also be marked for use in a Zone. The marking requirements are similar to those existing prior to the ATEX directive.

### 6.4.3.1

#### Equipment Marking for Class-Division

Equipment must be marked to show the Class, Group, and operating temperature or temperature Class referenced to a 40 °C ambient temperature. Electrical equipment suitable for ambient temperatures exceeding 40 °C must be marked with both the ambient temperature and the operating temperature or temperature Class at that ambient temperature. Equipment of the non-heat-producing type, such as junction boxes, conduits and fittings, is not required to have the operating temperature or temperature Class marked. The coding is identical for the USA and Canada.

Table 27: Sample Equipment Marking: "Class I, Division 1, Groups A&B, T4"

Marking	Meaning
Class I	Flammable gas or vapor environments
Division 1	Explosive atmosphere can exist under normal operating conditions
Groups A & B	A: Acetylene / B: Hydrogen
T4	Surface temperature will not exceed 135 °C (275 °F) under specified conditions.

### 6.4.3.2

#### Equipment Marking for Class-Zone

Because not all Division 1 equipment is suitable for Zone 0, it is necessary to pay special attention when marking Division-based equipment for use in Zone-classified areas. Markings are identical between the USA and Canada.

Intrinsically safe products suitable for with certain Class I, Division 1 requirements may be marked as meeting Zone 0 requirements as follows:

**Table 28: Zone 0 Group markings permitted for Class I, Division 1**

Intrinsically safe equipment marked as Class I, Division 1...	May also be marked as Class I, Zone 0...
Group A and Group B	Group IIC
Group B	Group IIB + H2
Group C	Group IIB
Group D	Group IIA

In general, products suitable for Class I, Division 1 locations may be marked for use in Zone 1 as follows:

**Table 29: Zone 1 Group markings permitted for Class I, Division 1**

Equipment marked as Class I, Division 1...	May also be marked as Class I, Zone 1...
Group A and Group B	Group IIC
Group B	Group IIB + H2
Group C	Group IIB
Group D	Group IIA

Products suitable for Class I, Division 2 locations may be marked for use in Zone 2 as follows:

**Table 30: Zone 2 Group markings permitted for Class I, Division 2**

Equipment marked as Class I, Division 2...	May also be marked as Class I, Zone 2...
Group A and Group B	Group IIC
Group B	Group IIB + H2
Group C	Group IIB
Group D	Group IIA

## 6.4.3.2.1

### Example Markings for Division-Based Zone Certification

**Table 31: Example marking: Class I, Division 1, Group IIB + H2, T6**

Marking	Meaning
Class I	The equipment is suitable for use in environments containing flammable gas or vapor.
Zone 1	The equipment is suitable for use in environments where an explosive atmosphere is likely to exist under normal operating conditions.
Group IIB + H2	The equipment is suitable for use in environments consisting of Ethylene and/or Hydrogen.
T6	The surface temperature of the equipment will not exceed 85 °C (185 °F).

## 6.4.3.2.2

### Example Markings for IEC-based Zone certification

The markings between the USA and Canada are different. The Canadian marking is identical to the IEC marking.

**Table 32: Example marking (Canada): EX ia IIC T4**

Marking	Meaning
EX	Approved to Canadian standards
ia	Intrinsic safety
IIC	Acetylene & hydrogen atmospheres
T4	135 °C maximum surface temperature

**Table 33: Example marking (USA): Class I, Zone 0, AEx ia IIC T4**

Marking	Meaning
Class I	Flammable gas or vapor
Zone 0	Explosive atmosphere always present
AEx	Approved to US standards
ia	Intrinsic safety
IIC	Acetylene and Hydrogen
T4	135 °C maximum surface temperature

# Section 7

## Appendices

## Appendix I Definitions and Abbreviations

<b>ACB</b>	Accepted Certification Bodies
<b>Assembly</b>	A combination of two or more pieces of equipment, together with components if necessary, and placed on the market and/or put into service as a single functional unit
<b>Associated apparatus</b>	Electrical apparatus which contains both intrinsically safe and non-intrinsically safe circuits and is constructed so that the non-intrinsically safe circuits cannot adversely affect the intrinsically safe circuits
<b>ATEX</b>	<b>AT</b> mosphères <b>EX</b> plosibles
<b>ATR</b>	Assessment and Test Report
<b>Attestation of Conformity for Components</b>	Declaration by the manufacturer that the components conform with the provisions of Directive 2014/34/EU and includes details on how to be incorporated into equipment or protective systems
<b>BASEEFA</b>	British Approval Service for Electrical Equipment in Flammable Atmospheres – UK Notified Body
<b>CAD</b>	Chemical Agents Directive 2014/27/EU – Protection of the health and safety of workers from risks related to chemical agents at work
<b>CEC</b>	Canadian Electrical Code
<b>CEN</b>	European Committee for standardisation (Non-electrical)
<b>CENELEC</b>	European Committee for Electrotechnical standardisation
<b>Clearance</b>	Shortest distance in air between two conductive parts
<b>CoC</b>	Certificate of Conformity (e.g. IECEx-Scheme)
<b>Combustible dust</b>	finely divided solid particles, 500 µm or less in nominal size, which may be suspended in air, may settle out of the atmosphere under their own weight, may burn or glow in air, and may form explosive mixtures with air at atmospheric pressure and normal temperatures
<b>Conductive dust</b>	Dust with electrical resistivity equal to or less than 10 <sup>3</sup> Ωm
<b>Creepage distance</b>	Shortest distance along the surface of an insulating medium between two conductive parts
<b>Da, Db, Dc</b>	Equipment Protection Levels for Dusts
<b>DSEAR</b>	Dangerous Substances and Explosive Atmospheres Regulations
<b>Dust protected</b>	Enclosure in which the ingress of dust is not totally prevented but dust does not enter in sufficient quantities to interfere with the safe operation of the equipment; dust must not accumulate in a position within the enclosure where it is liable to cause an ignition hazard
<b>Dust-ignition-proof</b>	Enclosed in a manner that will exclude dusts and will not permit arcs, sparks or heat otherwise generated inside of the enclosure to cause ignition of exterior layers or clouds of a specified dust on or in the vicinity of the enclosure
<b>Dust-tight</b>	Constructed so that dust particles will not enter the enclosure
<b>EC</b>	European Community
<b>EC Declaration of Conformity</b>	Declaration by the manufacturer that the equipment complies with the EHSR's of Directive 2014/34/EU and any other relevant directives that apply

<b>EHSR</b>	Essential Health and Safety Requirements
<b>Equipment</b>	Machines, apparatus, fixed or mobile devices, control components and instrumentation thereof and detection or prevention systems which, separately or jointly, are intended for the generation, transfer, storage, measurement, control and conversion of energy for the processing of material and which are capable of causing an explosion through their own potential sources of ignition
<b>Equipment Protection Level (EPL)</b>	Level of protection assigned to equipment based on its likelihood of becoming a source of ignition and distinguishing the differences between explosive gas atmospheres, explosive dust atmospheres, and the explosive atmospheres in mines susceptible to firedamp
<b>EU</b>	European Union
<b>Ex component</b>	Part of electrical equipment or a module, marked with the symbol "U", which is not intended to be used alone and requires additional consideration when incorporated into electrical equipment or systems for use in explosive atmospheres
<b>ExNB</b>	Ex Notified Bodies
<b>Explosionproof apparatus (US)</b>	Apparatus enclosed in a case that is capable of withstanding an explosion of a specified gas or vapour that may occur within it and of preventing the ignition of a specified gas or vapour surrounding the enclosure by sparks, flashes, or explosion of the gas or vapour within and that operates at such an external temperature that a surrounding flammable atmosphere will not be ignited thereby
<b>ExTL</b>	Ex Testing Laboratory
<b>ExTR</b>	IECEX Test Report
<b>FISCO</b>	Fieldbus Intrinsically Safe COnccept
<b>Flameproof (EU)</b>	A type of protection in which the parts which can ignite an explosive atmosphere are placed in an enclosure which can withstand the pressure developed during an internal explosion of an explosive mixture and which prevents the transmission of the explosion to the explosive atmosphere surrounding the enclosure
<b>Flash point</b>	The lowest liquid temperature at which a liquid gives off vapours in a quantity such as to be capable of forming an ignitable vapour/air mixture
<b>Ga, Gb, Gc</b>	Equipment Protection Levels for Gas
<b>Harmonised standards</b>	Standards developed specifically to allow a presumption of conformity with the EHSR of Directive 2014/34/EU
<b>Hermetically sealed component</b>	A component that is sealed against entrance of an external atmosphere and in which the seal is made by fusion, such as soldering, brazing, welding, or the fusion of glass to metal
<b>Increased safety</b>	A type of protection in which additional measures are applied to give increased security against the possibility of excessive temperatures and the occurrence of arcs and sparks inside and on external parts of electrical apparatus which does not produce arcs or sparks in normal service
<b>Installation</b>	A combination of two or more pieces of equipment, which were already placed on the market independently by one or more manufacturers
<b>Intrinsically safe apparatus</b>	Apparatus in which all the circuits are intrinsically safe

<b>Intrinsically safe circuit</b>	A circuit in which any spark or thermal effect produced is not capable of causing ignition of a mixture of flammable or combustible material in air under prescribed test conditions
<b>IP</b>	Ingress Protection
<b>KEMA</b>	Dutch Notified Body
<b>LEL</b>	Lower Explosion Limit
<b>MESG</b>	Maximum Experimental Safety Gap
<b>MIC</b>	Minimum Ignition Current
<b>NEC</b>	National Electrical Code
<b>Non-conductive dust</b>	Combustible dust with electrical resistivity greater than 10 <sup>3</sup> Ω·m
<b>Non-incendive circuit</b>	A circuit in which any arc or thermal effect produced under intended operating conditions of the equipment is not capable, under the test conditions specified, of igniting the specified flammable gas- or vapour- air mixture
<b>Non-incendive component</b>	A component having contacts for making or breaking an incendive circuit and the contacting mechanism shall be constructed so that the component is incapable of igniting the specified flammable gas- or air-air mixture. The housing of a nonincendive component is not intended to exclude the flammable atmosphere or contain an explosion
<b>Non-incendive field circuit</b>	A circuit that enters or leaves the equipment enclosure and that under intended operating conditions is not capable, under the test conditions specified, of igniting the specified flammable gas- or air-air mixture or combustible dust
<b>Non-sparking apparatus</b>	Apparatus that has no normally arcing parts or thermal effects capable of ignition. Normal use excludes the removal or insertion of components with the circuit energised
<b>Notified Body</b>	A Notified Body, in the European Union, is an organisation that has been accredited by a Member State to assess whether a product meets certain preordained standards. Assessment can include inspection and examination of a product, its design and manufacture.
<b>Pressurization</b>	The process of supplying an enclosure with a protective gas with or without continuous flow at sufficient pressure to prevent the entrance of a flammable gas or vapour, a combustible dust, or an ignitable fibre
<b>Protective systems</b>	Design units, which are intended to halt incipient explosions immediately and/or to limit the effective range of explosion flames and explosion pressures. Protective systems may be integrated into equipment or separately placed on the market for use as autonomous systems
<b>PTB</b>	German Notified Body
<b>Purging</b>	The process of supplying an enclosure with a protective gas at a sufficient flow and positive pressure to reduce the concentration of any flammable gas or vapour initially present to an acceptable level
<b>QAR</b>	IECEX-Scheme Quality Assessment Report
<b>Relative density of a gas/vapour</b>	The density of a gas or a vapour relative to the density of air at the same pressure and at the same temperature (air is equal to 1,0)

<b>Sealed device</b>	A device that is constructed so that it cannot be opened, has no external operating mechanisms, and is sealed to restrict entry of an external atmosphere without relying on gaskets. The device may contain arcing parts or internal hot surfaces
<b>Simple apparatus</b>	An electrical component or combination of components of simple construction with well defined electrical parameters which is compatible with the intrinsic safety of the circuit in which it is used
<b>“U” Symbol</b>	The symbol used as a suffix to a certificate reference to denote special conditions for safe use
<b>UEL</b>	Upper Explosion Limit
<b>“X” Symbol</b>	The symbol used as a suffix to a certificate reference to denote special conditions for safe use

## Appendix II Ingress and Impact protection for enclosures

Table 34: Ingress and Impact protection for enclosures EN 60529 (IP) and EN 50102 (K)

1 ST Number			2 ND Number			2 RD Number		
IP	Protection against solid bodies		IP	Protection against liquids		K	Impact protection	
0		No protection	0		No protection	0		No protection
1		Protected against solid bodies larger than 50 mm (e.g.: accidental contact with the hand)	1		Protected against vertical water drops falling (condensation)	1	200g ▼ 7.5 cm ▲	Impact energy 0.150 J
2		Protected against solid bodies larger than 12 mm (e.g.: hand fingers)	2		Protected against drops of water falling up to 15° from the vertical	2	200g ▼ 10 cm ▲	Impact energy 0.200 J
3		Protected against solid bodies larger than 2.5 mm (e.g.: tools, and small wires, etc.)	3		Protected against drops of water falling up to 60° from the vertical	3	200g ▼ 17.5 cm ▲	Impact energy 0.350 J
4		Protected against solid bodies larger than 1 mm (e.g.: fine tools, wires, etc.)	4		Protected against water projected from all directions	4	200g ▼ 25 cm ▲	Impact energy 0.500 J
5		Protected against dust (no harmful deposit)	5		Protected against jets of water from all directions	5	200g ▼ 35 cm ▲	Impact energy 0.700 J
6		Completely protected against dust	6		Protected against jets of water of similar force to heavy sea waves	6	500g ▼ 20 cm ▲	Impact energy 1.00 J
			7		Protected against effects of immersion	7	500g ▼ 40 cm ▲	Impact energy 2.00 J
			8		Protected against the continuors effects of immersion under pressure and have to be agreed between manufacturer and customer	8	1.7Kg ▼ 29.5 cm ▲	Impact energy 5.00 J
						9	5Kg ▼ 20 cm ▲	Impact energy 10.00 J
						10	5Kg ▼ 40 cm ▲	Impact energy 20.00 J

### Appendix III Terminal Content using the 'Defined Arrangement Method'

The 'Defined Arrangement Method' specifies a set of values comprising, for each conductor size, the permissible number of conductors and the maximum current. If more than one combination is possible, then the information is presented in a table.

The amount of heat loss depends on the size of the enclosure. Therefore, each table is unique for a specific enclosure size. Our example is a Weidmuller enclosure Klippon TB MH 30/30/20 (H300xW300xD200).

Table 35: Klippon TB MH 30/30/20

		Cross-section [mm <sup>2</sup> ]															
		1,5	2,5	4	6	10	16	25	35	50	70	95	120	150	185	240	300
		<b>Maximum number of conductors</b>															
Current [A]	6																
	10	62	112														
	15	28	48	82													
	21		22	40	66												
	28			24	40	104											
	36				18	38	118										
	50					16	32	108									
	66						16	32	70								
	88							14	24	54							
	109								14	26	62						
	131									14	26						
	167										12	22	42				
	202											12	20	34			
	234												14	22	46		
	267													12	18	56	
	307															12	22
	361																12
452																	8

For our first application we select a conductor size of 2.5 mm<sup>2</sup> @ 10 Amps. According to our table, the permissible number of conductors is 112 (e.g. 56 WDU 2.5 terminals).

This number is not necessarily the physical number of terminals that can be fitted in the enclosure.

For the smaller cross sections, the power dissipation depends on the cable size, as the resistance of a quality terminal is negligible. Therefore, the number in the table is in fact the number of cables that can be terminated in the enclosure and is not dependent on the size of terminal that is selected.

Table 36: Klippon TB MH 30/30/20

		Cross-section [mm <sup>2</sup> ]															
		1,5	2,5	4	6	10	16	25	35	50	70	95	120	150	185	240	300
		<b>Maximum number of conductors</b>															
Current [A]	6																
	10	62	112														
	15	28	48	82													
	21		22	40	66												
	28			24	40	104											
	36				18	38	118										
	50					16	32	108									
	66						16	32	70								
	88							14	24	54							
	109								14	26	62						
	131									14	26						
	167										12	22	42				
	202											12	20	34			
	234												14	22	46		
	267													12	18	56	
	307															12	22
	361																12
452																	8

The actual physical terminal content of our KLIPPON TB MH 30/30/20 enclosure depends on the terminal size that is selected for the application. We take the Weidmuller WDU type, mounted on vertical rails, as an example.

If you select the WDU 2.5 you can fit 82 terminals in the enclosure because of physical constraints. If you select a larger terminal such as the WDU 4 you can fit even less terminals in the enclosure i.e. 68. Both is higher than the permissible number of 56. This is not allowed.

Table 37: Physical content table

Type	Rows	Terminals
WDU 2.5	2	41
WDU 4	2	34

Note: Maximum terminal content for guidance only

For our second application we select the same conductor size but the current rating is 15 Amps. According to our table the permissible number of conductors is 48 (e.g. 24 WDU 2.5 terminals). Using the same terminals types as before, the maximum physical terminal content is higher than the permissible number of terminals in the table. This is not allowed.

Therefore the maximum number of terminals that can be fitted in the Klippon TB MH 30/30/20 is 24. Even if you use a larger terminal size, i.e. WDU 4, you are only allowed 24 terminals because the conductor size of 2.5 mm<sup>2</sup> is the limiting factor.

Table 38: Klippon TB MH 30/30/20

		Cross-section [mm <sup>2</sup> ]																							
		1,5	2,5	4	6	10	16	25	35	50	70	95	120	150	185	240	300								
Current [A]		Maximum number of conductors																							
	6																								
	10	62	112																						
	15	28	48	82																					
	21		22	40	66																				
	28			24	40	104																			
	36				18	38	118																		
	50					16	32	108																	
	66						16	32	70																
	88							14	24	54															
	109								14	26	62														
	131									14	26														
	167										12	22	42												
	202		In this area the maximum load limit is not permissible.											12	20	34									
	234																			14	22	46			
	267																				12	18	56		
	307																					12	22		
361														12	20										
452																8									

Even if you increase the conductor size to 4 mm<sup>2</sup> @ 15 Amps, this would increase the permissible number of conductors to 82 (e.g. 41 WDU 4 terminals), the physical constraints do not limit the maximum number of terminals that can be fitted in the enclosure.

Table 39: Klippon TB MH 30/30/20

		Cross-section [mm <sup>2</sup> ]															
		1,5	2,5	4	6	10	16	25	35	50	70	95	120	150	185	240	300
		<b>Maximum number of conductors</b>															
Current [A]	6																
	10	62	112														
	15	28	48	82													
	21		22	40	66												
	28			24	40	104											
	36				18	38	118										
	50					16	32	108									
	66						16	32	70								
	88							14	24	54							
	109								14	26	62						
	131									14	26						
	167										12	22	42				
	202											12	20	34			
	234												14	22	46		
	267													12	18	56	
	307														12	22	
361															12	20	
452																8	

Different sizes of terminals can be mixed together by utilising the tabular values proportionally. The loading of the different terminal types is calculated by taking the number of installed conductor divided by the corresponding permissible number of terminals in the table. The sum of the individual loads must always be less than 100 %. If the total load is more than 100 %, reduce the number of terminals or select a larger enclosure.

Table 40: Klippon TB MH 30/30/20

		Cross-section [mm <sup>2</sup> ]															
		1,5	2,5	4	6	10	16	25	35	50	70	95	120	150	185	240	300
		<b>Maximum number of conductors</b>															
Current [A]	6																
	10	62	112														
	15	28	48	82													
	21		22	40	66												
	28			24	40	104											
	36				18	38	118										
	50					16	32	108									
	66						16	32	70								
	88							14	24	54							
	109								14	26	62						
	131									14	26						
	167										12	22	42				
	202											12	20	34			
	234												14	22	46		
	267													12	18	56	
	307														12	22	
361															12	20	
452																8	

Table 41: Calculation of total load (example ZDU)

Conductor size (mm <sup>2</sup> )	Current (Amps)	Number of conductors	Load ≤ 100 %
1.5	10	30 (permissible 62)	30/62 = 48.40 %
4	21	10 (permissible 40)	10/40 = 25.00 %
10	36	6 (permissible 38)	6/38 = 15.80 %
			<b>89.20 %</b>

e.g. 15 x ZDU 1.5, 5 x ZDU 4 and 3 x ZDU 10

## Appendix IV Inspection schedules for gas atmospheres

Table 42: Inspection schedule for Ex 'd', Ex 'e' and Ex 'n' installations

Check that:		Ex 'd'			Ex 'e'			Ex 'n'		
		Grade of inspection (D = Detailed, C = Close, V = Visual)								
		D	C	V	D	C	V	D	C	V
<b>A EQUIPMENT</b>										
1	Equipment is appropriate to area classification (EPL or zone)	*	*	*	*	*	*	*	*	*
2	Equipment group is correct	*	*		*	*		*	*	
3	Equipment temperature class is correct	*	*		*	*		*	*	
4	Equipment circuit identification is correct	*			*			*		
5	Equipment circuit identification is available	*	*	*	*	*	*	*	*	*
6	Enclosure, glasses and glass-to-metal sealing gaskets and/or compounds are satisfactory	*	*	*	*	*	*	*	*	*
7	There are no unauthorised modifications	*			*			*		
8	There are no visible unauthorised modifications		*	*		*	*		*	*
9	Bolts, cable entry devices (direct and indirect) and blanking elements are of the correct type and are complete and tight									
	- Physical check	*	*		*	*		*	*	
	- Visual check			*			*			*
10	Flange faces are clean and undamaged and gaskets, if any, are satisfactory	*								
11	Flange gap dimensions are within maximal values permitted	*	*							
12	Lamp rating, type and position are correct	*			*			*		
13	Electrical connections are tight				*			*		
14	Condition of enclosure gaskets is satisfactory				*			*		
15	Enclosed-break and hermetically sealed devices are undamaged							*		
16	Restricted breathing enclosure is satisfactory							*		
17	Motor fans have sufficient clearance to enclosure and/or covers	*			*			*		
18	Breathing and draining devices are satisfactory	*	*		*	*		*	*	
<b>B INSTALLATION</b>										
1	Type of cable is appropriate	*			*			*		
2	There is no obvious damage to cables	*	*	*	*	*	*	*	*	*
3	Sealing of trunking, ducts, pipes and/or conduits is satisfactory	*	*	*	*	*	*	*	*	*
4	Stopper boxes and cable boxes are correctly fitted	*								
5	Integrity of conduit system and interface with mixed system is maintained	*			*			*		
6	Earthing connections, including any supplementary earthing bonding connections are satisfactory (e.g. connections are tight and conductors are of sufficient cross-section)									
	- Physical check	*			*			*		
	- Visual check		*	*		*	*		*	*
7	Fault loop impedance (TN system) or earthing resistance (IT system) is satisfactory	*			*			*		
8	Insulation resistance is satisfactory	*			*			*		
9	Automatic electrical protective devices operate within permitted limits	*			*			*		
10	Automatic electrical protective devices are set correctly (auto-reset not possible)	*			*			*		
11	Special conditions of use (if applicable) are complied with	*			*			*		
12	Cables not in use are correctly terminated	*			*			*		
13	Obstructions adjacent to flameproof flanged joints are in accordance with EN 60079-14	*	*	*						
14	Variable voltage/frequency installation in accordance with documentation	*	*		*	*		*	*	
<b>C ENVIRONMENT</b>										
1	Apparatus is adequately protected against corrosion, weather, vibration and other adverse factors	*	*	*	*	*	*	*	*	*
2	No undue accumulation of dust and dirt	*	*	*	*	*	*	*	*	*
3	Electrical insulation is clean and dry				*			*		

Notes

- General: the checks used for apparatus using both types of protection 'e' and 'd' will be a combination of both columns
- Items B7 and B8: account should be taken of the possibility of an explosive atmosphere in the vicinity of the apparatus when using electrical test equipment

Table 43: Inspection schedule for Ex 'i' installations

Check that:	Grade of inspection		
	Detailed	Close	Visual
<b>A EQUIPMENT</b>			
1 Circuit and/or apparatus documentation is appropriate to area classification (EPL and zone)	*	*	*
2 Equipment installed is that specified in the documentation – Fixed apparatus only	*	*	
3 Circuit and/or apparatus category and group correct	*	*	
4 Equipment temperature class is correct	*	*	
5 Installation is clearly labelled	*	*	
6 Enclosure, glasses and glass-to-metal sealing gaskets and/or compounds are satisfactory	*		
7 There are no unauthorised modifications	*		
8 There are no visible unauthorised modifications		*	*
9 Safety barrier units, relays and other energy limiting devices are of the approved type, installed in accordance with the certification requirements and securely earthed where required	*	*	*
10 Electrical connections are tight	*		
11 Printed circuit boards are clean and undamaged	*		
<b>B INSTALLATION</b>			
1 Cables are installed in accordance with the documentation	*		
2 Cable screens are earthed in accordance with the documentation	*		
3 There is no obvious damage to cables	*	*	*
4 Sealing of trunking, ducts, pipes and/or conduits is satisfactory	*	*	*
5 Point-to-point connections are all correct	*		
6 Earth continuity is satisfactory for non-galvanic isolated circuits (e.g. connections are tight and conductors are of sufficient cross-section)	*		
7 Earth connections maintain the integrity of the type of protection	*	*	*
8 The intrinsically safe circuit is isolated from earth and the earthing is sufficient	*		
9 Separation is maintained between intrinsically safe and non-intrinsically safe circuits in common distribution boxes or relay cubicles	*		
10 As applicable, short-circuit protection of the power supply is in accordance with the documentation	*		
11 Special conditions of use (if applicable) are complied with	*		
12 Cables not in use are correctly terminated	*	*	*
<b>C ENVIRONMENT</b>			
1 Equipment is adequately protected against corrosion, weather, vibration and other adverse factors	*	*	*
2 No undue accumulation of dust and dirt	*	*	*

Table 44: Inspection schedule for Ex 'p' or "pD" installations

Check that:		Grade of inspection		
		Detailed	Close	Visual
<b>A</b>	<b>EQUIPMENT</b>			
1	Equipment is appropriate to area classification (EPL and zone)	*	*	*
2	Equipment group is correct	*	*	
3	Equipment temperature class is correct	*	*	
4	Equipment circuit identification is correct	*		
5	Equipment circuit identification is available	*	*	*
6	Enclosure, glasses and glass-to-metal sealing gaskets and/or compounds are satisfactory	*	*	*
7	There are no unauthorised modifications	*		
8	There are no visible unauthorised modifications		*	*
9	Lamp rating, type and position are correct	*		
<b>B</b>	<b>INSTALLATION</b>			
1	Type of cable is appropriate	*		
2	There is no obvious damage to cables	*	*	*
3	Earthing connections, including any supplementary earthing bonding connections are satisfactory (e.g. connections are tight and conductors are of sufficient cross-section)			
	- Physical check	*		
	- Visual check		*	*
4	Fault loop impedance (TN system) or earthing resistance (IT system) is satisfactory	*		
5	Automatic electrical protective devices operate within permitted limits	*		
6	Automatic electrical protective devices are set correctly	*		
7	Protective gas inlet temperature is below maximum specified	*		
8	Ducts, pipes and enclosures are in good condition	*	*	*
9	Protective gas is substantially free from contaminants	*	*	*
10	Protective gas pressure and/or flow is adequate	*	*	*
11	Pressure and/or flow indicators, alarms and interlocks function correctly	*		
12	Conditions of spark and particle barriers of ducts for exhausting the gas in hazardous area are satisfactory	*		
13	Special conditions of use (if applicable) are complied with	*		
<b>C</b>	<b>ENVIRONMENT</b>			
1	Equipment is adequately protected against corrosion, weather, vibration and other adverse factors	*	*	*
2	No undue accumulation of dust and dirt	*	*	*

Table 45: Inspection schedule for Ex installations

Check that:	Grade of inspection		
	Detailed	Close	Visual
<b>A EQUIPMENT</b>			
1 Equipment is appropriate to area classification (EPL and zone)	*	*	*
2 IP rating of the equipment is correct for conductive dust	*	*	*
3 Maximum surface temperature is correct	*	*	
4 Equipment circuit identification is correct	*		
5 Equipment circuit identification is available	*	*	*
6 Enclosure, gaskets and glass-to-metal sealing gaskets and/or compounds are satisfactory	*	*	*
7 There are no unauthorised modifications	*		
8 There are no visible unauthorised modifications		*	*
9 Bolts, cable entry devices (direct and indirect) and blanking elements are of the correct type and are complete and tight - Physical check - Visual check	*	*	*
10 Lamp rating, type and position are correct	*		
11 Electrical connections are tight	*		
12 Condition of enclosure gaskets is satisfactory	*		
13 Motor fans have sufficient clearance to enclosure and/or covers	*		
<b>B INSTALLATION</b>			
1 Accumulation of dust and dirt is avoided	*	*	*
2 Type of cable is appropriate	*		
3 There is no obvious damage to cables	*	*	*
4 Sealing of trunking, ducts, pipes and/or conduits is satisfactory	*	*	*
5 Earthing connections, including any supplementary earthing bonding connections are satisfactory (e.g. connections are tight and conductors are of sufficient cross-section) - Physical check - Visual check	*	*	*
6 Fault loop impedance (TN system) or earthing resistance (IT system) is satisfactory	*		
7 Insulation resistance is satisfactory	*		
8 Automatic electrical protective devices operate within permitted limits	*		
9 Special conditions of use (if applicable) are complied with	*		
10 Cables not in use are correctly terminated	*	*	
<b>C ENVIRONMENT</b>			
1 Equipment is adequately protected against corrosion, weather, vibration and other adverse factors	*	*	*
2 No undue accumulation of dust and dirt	*	*	*

## Appendix V Inspection schedules for dust atmospheres

Table 46: Inspection schedule for Ex "i" installations

Check that:	Grade of inspection		
	Detailed	Close	Visual
<b>A EQUIPMENT</b>			
1 Circuit and/or equipment documentation is appropriate to the EPL/zone requirements of the location	*	*	*
2 Equipment installed is that specified in the documentation - Fixed equipment only	*	*	
3 Circuit and/or equipment category and group correct	*	*	
4 Equipment temperature class is correct	*	*	
5 Installation is clearly labelled	*	*	
6 Enclosure, glass parts and glass-to-metal sealing gaskets and/or compounds are satisfactory	*		
7 There are no unauthorized modifications	*		
8 There are no visible unauthorized modifications		*	*
9 Safety barrier units, relays and other energy limiting devices are of the approved type, installed in accordance with the certification	*	*	*
10 Electrical connections are tight	*		
11 Printed circuit boards are clean and undamaged	*		
<b>B INSTALLATION</b>			
1 Cables are installed in accordance with the documentation	*		
2 Cable screens are earthed in accordance with the documentation	*		
3 There is no obvious damage to cables	*	*	*
4 Sealing of trunking, ducts, pipes and/or conduits is satisfactory	*	*	*
5 Point-to-point connections are all correct	*		
6 Earth continuity is satisfactory (e.g. connections are tight, conductors are of sufficient cross-section) for non-galvanically isolated circuits.	*		
7 Earth connections maintain the integrity of the type of protection	*	*	*
8 Intrinsically safe circuit earthing and insulation resistance is satisfactory	*		
9 Separation is maintained between intrinsically safe and non-intrinsically safe circuits in common distribution boxes or relay cubicles	*		
10 As applicable, short-circuit protection of the power supply is in accordance with the documentation	*		
11 Specific conditions of use (if applicable) are complied with	*		
12 Cables not in use are correctly terminated	*		
<b>C ENVIRONMENT</b>			
1 Equipment is adequately protected against corrosion, weather, vibration and other adverse factors	*	*	*
2 No undue external accumulation of dust and dirt	*	*	*

Table 47: Inspection schedule for Ex “p” and “pD” installations

Check that:	Grade of inspection			
	Detailed	Close	Visual	
<b>A EQUIPMENT</b>				
1	Equipment is appropriate to the EPL/zone requirements of the location	*	*	*
2	Equipment group is correct	*	*	
3	Equipment temperature class or surface temperature is correct	*	*	
4	Equipment circuit identification is correct	*		
5	Equipment circuit identification is available	*	*	*
6	Enclosure, glasses and glass-to-metal sealing gaskets and/or compounds are satisfactory	*	*	*
7	There are no unauthorized modifications	*		
8	There are no visible unauthorized modifications		*	*
9	Lamp rating, type and position are correct	*		
<b>B INSTALLATION</b>				
1	Type of cable is appropriate	*		
2	There is no obvious damage to cables	*	*	*
3	Earthing connections, including any supplementary earthing bonding connections, are satisfactory, for example connections are tight and conductors are of sufficient cross-section - physical check - visual check	*	*	*
4	Fault loop impedance (TN systems) or earthing resistance (IT systems) is satisfactory	*		
5	Automatic electrical protective devices operate within permitted limits	*		
6	Automatic electrical protective devices are set correctly	*		
7	Protective gas inlet temperature is below maximum specified	*		
8	Ducts, pipes and enclosures are in good condition	*	*	*
9	Protective gas is substantially free from contaminants	*	*	*
10	Protective gas pressure and/or flow is adequate	*	*	*
11	Pressure and/or flow indicators, alarms and interlocks function correctly	*		
12	Conditions of spark and particle barriers of ducts for exhausting the gas in hazardous area are satisfactory	*		
13	Specific conditions of use (if applicable) are complied with	*		
<b>C ENVIRONMENT</b>				
1	Equipment is adequately protected against corrosion, weather, vibration and other adverse factors	*	*	*
2	No undue accumulation of dust and dirt	*	*	*

Table 48: Inspection schedule for Ex “t” installations

Check that:	Grade of inspection		
	Detailed	Close	Visual
<b>A EQUIPMENT</b>			
1 Equipment is appropriate to the EPL/zone requirements of the location	*	*	*
2 IP grade of equipment is appropriate to conductivity of dust	*	*	*
3 Equipment maximum surface temperature is correct	*	*	
4 Equipment circuit identification is available	*	*	*
5 Equipment circuit identification is correct	*		
6 Enclosure, glasses and glass to metal sealing gaskets and/or compounds are satisfactory	*	*	*
7 There are no unauthorized modifications	*		
8 There are no visible unauthorized modifications		*	*
9 Bolts, cable entry devices and blanking elements are of the correct type and are complete and tight - physical check - visual check	*	*	*
10 Lamp rating, type and position are correct	*		
11 Electrical connections are tight	*		
12 Condition of enclosure gaskets is satisfactory	*		
13 Motor fans have sufficient clearance to enclosure and/or covers	*		
<b>B INSTALLATION</b>			
1 The installation is such as to minimize the risk of dust accumulations	*	*	*
2 Type of cable is appropriate	*		
3 There is no obvious damage to cables	*	*	*
4 Sealing of trunking, ducts, pipes and/or conduits is satisfactory	*	*	*
5 Earthing connections, including any supplementary earthing bonding connections are satisfactory - physical check - visual check	*	*	*
6 Fault loop impedance (TN systems) or earthing resistance (IT systems) is satisfactory	*		
7 Insulation resistance is satisfactory	*		
8 Automatic electrical protective devices operate within permitted limited	*		
10 Specific conditions of use (if applicable) are compiled with	*		
11 Cables not in use are correctly terminated	*	*	
<b>C ENVIRONMENT</b>			
1 Equipment is adequately protected against corrosion, weather, vibration and other adverse conditions	*	*	*
2 No undue accumulation of dust and dirt	*	*	*

## Appendix VI Environmental Type designations for enclosures

Table 49: Environmental Type designations for enclosures

Enclosure Type Designation	Intended Use and Description
1	Indoor use primarily to provide a degree of protection against limited amounts of falling dirt.
2	Indoor use primarily to provide a degree of protection against limited amounts of falling water and dirt.
3	Outdoor use primarily to provide a degree of protection against rain, sleet, wind blown dust and damage from external ice formation.
3R	Outdoor use primarily to provide a degree of protection against rain, sleet, and damage from external ice formation.
3S	Outdoor use primarily to provide a degree of protection against rain, sleet, windblown dust and to provide for operation of external mechanisms when ice laden.
4	Indoor or outdoor use primarily to provide a degree of protection against windblown dust and rain, splashing water, hose-directed water and damage from external ice formation.
4X	Indoor or outdoor use primarily to provide a degree of protection against corrosion, windblown dust and rain, splashing water, hose-directed water, and damage from external ice formation.
5	Indoor use primarily to provide a degree of protection against settling airborne dust, falling dirt, and dripping noncorrosive liquids.
6	Indoor or outdoor use primarily to provide a degree of protection against hose-directed water, and the entry of water during occasional temporary submersion at a limited depth and damage from external ice formation.
6P	Indoor or outdoor use primarily to provide a degree of protection against hose-directed water, the entry of water during prolonged submersion at a limited depth and damage from external ice formation.
7	Indoor use in locations classified as Class I, Division 1, Groups A, B, C or D hazardous locations as defined in the National Electric Code (NFPA 70) (Commonly referred to as explosion-proof).
8	Indoor or outdoor use in locations classified as Class I, Division 2, Groups A, B, C or D hazardous locations as defined in the National Electric Code (NFPA 70) (commonly referred to as oil immersed).
9	Indoor use in locations classified as Class II, Division 1, Groups E, F and G hazardous locations as defined in the National Electric Code (NFPA 70) (commonly referred to as dust-ignition proof).
10	Intended to meet the applicable requirements of the Mine Safety and Health Administration (MSHA).
12 and 12K	Indoor use primarily to provide a degree of protection against circulating dust, falling dirt, and dripping noncorrosive liquids.
13	Indoor use primarily to provide a degree of protection against dust, spraying of water, oil, and noncorrosive coolant.

The above "Types" are usually tested in accordance with:

- ANSI/UL50, Enclosures for Electrical Equipment for Types 1, 2, 3, 3R, 3S, 4, 4X, 5, 6, 6P, 12, 12K and 13.
- ANSI/UL698, Industrial Control Equipment for Use in Hazardous (Classified) Locations and other related standards for Types 7, 8 and 9.
- ANSI/NEMA250, Enclosures for Electrical Equipment (1000 Volts Maximum) for Types 1, 2, 3, 3R, 3S, 4, 4X, 5, 6, 6P, 7, 8, 9, 12, 12K and 13.

# Appendix VII Certifications



**IBEXU Institut für Sicherheitstechnik GmbH**  
An-Institut der TU Bergakademie Freiberg

**EC-TYPE EXAMINATION CERTIFICATE**  
according to Directive 94/9/EC Annex II (Ex)

**EC-Type Examination Certificate Number: IBEK07ATEX1147 U**

**Component:** Empty enclosure Type Klappex 378

**Manufacturer:** Weidmüller Interface GmbH & Co. KG  
**Address:** Klingenbergstr. 16, 32758 Detmold, Germany

The design of this component mentioned under (2) and any acceptable variation therein are specified in the schedule to this EC-Type Examination Certificate.

IBEXU Institut für Sicherheitstechnik GmbH, IECEx ID No. 091019, certifies that the equipment mentioned in (2) has been found to comply with the Essential Health and Safety Requirements relating to the design and construction of components intended for use in potentially explosive atmospheres as specified in Annex II to the Directive.

The test results are recorded in the test report (B-07-3-216 of 14<sup>th</sup> April 2008).

Compliance with the Essential Health and Safety Requirements has been assessed by conformity with EN 60079-0:2006, EN 60079-1:2007, EN 60079-11:2007, EN 61010-1:2006 and EN 61010-2:2004.

The sign „U“ placed after the certificate number indicates that this certificate must not be retained for a certificate intended for an equipment or protective system. This general certification may be only used as a basis for certification of an equipment or protective system.

This EC-Type Examination Certificate relates only to the design and construction of the specified component. If applicable, further requirements of the directive apply to the manufacture and supply of this component.

The marking of the component mentioned under (2) shall include one off the following:  
**Ex II 2D Ex e II G Ex II IC Ex II G Ex II A21 IP6X G Ex II G Ex II A21 IP6X**

IBEXU Institut für Sicherheitstechnik GmbH  
Friedbergweg 7 · 09599 Freiberg, Germany  
T +49 (0) 3731 3863-1 · F +49 (0) 3731 2260

Authorized for contributions  
Explosion protection  
Freiberg, 13<sup>th</sup> April 2008

By order  
Dr. Lorenz  
Schaube

**IBEXU Institut für Sicherheitstechnik GmbH**  
An-Institut der TU Bergakademie Freiberg

**EC-TYPE EXAMINATION CERTIFICATE**  
according to Directive 94/9/EC Annex II (Ex)

**EC-Type Examination Certificate Number: IBEK07ATEX1148**

**Equipment:** Control and distribution box Type Klappex 378 ...

**Manufacturer:** Weidmüller Interface GmbH & Co. KG  
**Address:** Klingenbergstr. 16, 32758 Detmold, Germany

The equipment mentioned in (2) and any acceptable variation therein are specified in the schedule to this EC-Type Examination Certificate.

IBEXU Institut für Sicherheitstechnik GmbH, IECEx ID No. 091019, certifies that the equipment mentioned in (2) has been found to comply with the Essential Health and Safety Requirements relating to the design and construction of equipment intended for use in potentially explosive atmospheres, given in Annex II to the Directive.

The test results are recorded in the test report (B-07-3-216 of 14<sup>th</sup> April 2008).

Compliance with the Essential Health and Safety Requirements has been assessed by conformity with EN 60079-0:2006, EN 60079-2:2007, EN 61079-1:2007, EN 61010-1:2006 and EN 61010-2:2004.

If the sign „X“ is placed after the certificate number, it indicates that the equipment is subject to special conditions for safe use specified under (3) in the schedule to this EC-Type Examination Certificate.

This EC-Type Examination Certificate relates only to the design and construction of the specified equipment. If applicable, further requirements of the directive apply to the manufacture and supply of this equipment.

The marking of the equipment mentioned in (2) shall include one off the following:  
**Ex II 2D Ex e II G Ex II IC Ex II G Ex II A21 IP6X G Ex II G Ex II A21 IP6X**  
T<sub>1</sub>, 0°C ~ +40°C ~ -55°C ~ -60°C

IBEXU Institut für Sicherheitstechnik GmbH  
Friedbergweg 7 · 09599 Freiberg, Germany  
T +49 (0) 3731 3863-1 · F +49 (0) 3731 2260

Authorized for contributions  
Explosion protection  
Freiberg, 13<sup>th</sup> April 2008

By order  
Dr. Lorenz  
Schaube

**IECEx Certificate of Conformity**  
INTERNATIONAL ELECTROTECHNICAL COMMISSION  
IEC Certification Scheme for Explosive Atmospheres

Certificate No.: IECEx 08 00162 Issue No. 0 Certificate history:

Status: Current

Date of Issue: 2010-01-26 Page 1 of 4

Applicant: Weidmüller Interface GmbH & Co. KG  
Klingenbergstrasse 16  
32758 Detmold  
Germany

Electrical Apparatus:  
Optional accessory: Empty enclosure of type Klappex 378

Type of Protection: Increased safety "n"; intrinsic safety "i"; Protection by enclosure "T"

Marking: Ex e IC Gb  
Ex e IC Gb  
Ex II IC Gb IP6X

Approved for issue on behalf of the IECEx  
Certification Body: Prof. Dr. Tarmo Reister  
Head of Certification Body

Signature: *[Signature]*  
Date: 2010-01-26

1. This certificate and schedule may only be reproduced in full.  
2. This certificate is not transferable and remains the property of the issuing body.  
3. The status and authenticity of this certificate may be verified by visiting the [Official IECEx Website](http://www.iecex.ch).

Certificate issued by:  
IBEXU Institut für Sicherheitstechnik GmbH  
Certification Body  
Friedbergweg 7  
09599 Freiberg  
Germany

**IBEXU**

IBEXU Institut für Sicherheitstechnik GmbH  
Friedbergweg 7 · 09599 Freiberg, Germany  
T +49 (0) 3731 3863-1 · F +49 (0) 3731 2260

Authorized for contributions  
Explosion protection  
Freiberg, 13<sup>th</sup> April 2008

By order  
Dr. Lorenz  
Schaube

IBEXU Institut für Sicherheitstechnik GmbH  
Friedbergweg 7 · 09599 Freiberg, Germany  
T +49 (0) 3731 3863-1 · F +49 (0) 3731 2260

Authorized for contributions  
Explosion protection  
Freiberg, 13<sup>th</sup> April 2008

By order  
Dr. Lorenz  
Schaube

IBEXU Institut für Sicherheitstechnik GmbH  
Friedbergweg 7 · 09599 Freiberg, Germany  
T +49 (0) 3731 3863-1 · F +49 (0) 3731 2260

Authorized for contributions  
Explosion protection  
Freiberg, 13<sup>th</sup> April 2008

By order  
Dr. Lorenz  
Schaube

**IECEx Certificate of Conformity**  
INTERNATIONAL ELECTROTECHNICAL COMMISSION  
IEC Certification Scheme for Explosive Atmospheres

Certificate No.: IECEx 08 00163 Issue No. 0 Certificate history:

Status: Current

Date of Issue: 2010-01-26 Page 1 of 4

Applicant: Weidmüller Interface GmbH & Co. KG  
Klingenbergstrasse 16  
32758 Detmold  
Germany

Electrical Apparatus:  
Optional accessory: Control and distribution box of type Klappex 378 ...

Type of Protection: Increased safety "n"; intrinsic safety "i"; Protection by enclosure "T"

Marking: Ex e IC Gb  
Ex e IC Gb  
Ex II IC Gb IP6X

Approved for issue on behalf of the IECEx  
Certification Body: Prof. Dr. Tarmo Reister  
Head of Certification Body

Signature: *[Signature]*  
Date: 2010-01-26

1. This certificate and schedule may only be reproduced in full.  
2. This certificate is not transferable and remains the property of the issuing body.  
3. The status and authenticity of this certificate may be verified by visiting the [Official IECEx Website](http://www.iecex.ch).

Certificate issued by:  
IBEXU Institut für Sicherheitstechnik GmbH  
Certification Body  
Friedbergweg 7  
09599 Freiberg  
Germany

**IBEXU**

**CERTIFICATE**  
**ISO 9001:2000**

**DEKRA**  
Certification

hereby certifies that the company  
**Weidmüller**

business field:  
development, construction and production of electronics, connection techniques, serial terminals, connectors, printed circuit boards and electronic components

locations:  
Weidmüller Interface GmbH & Co. KG · Klingenbergstraße 16 · D-32758 Detmold  
Thüringische Weidmüller GmbH · An der Allee 1 · D-99589 Mühlhausen  
Weidmüller Deutschland GmbH & Co. KG · Chiemstr. 9 · D-32758 Detmold  
Weidmüller MSP Service GmbH & Co. KG · Chiemstr. 4 · D-32758 Detmold

has successfully implemented the above mentioned quality management system according to the standard ISO 9001 and applies it effectively. The conformity was inspected during the certification audit documented in audit report no. AM021353. This certificate is only valid in connection with the successfully performance of the surveillance audits.

Date of the first certification: 02.06.1992 Date of the last certification: 18.06.2008  
This certificate is valid until: 17.06.2011 Certificate registration no.: 3030427632  
Last audit day: 21.05.2008 duplicate

*[Signature]* **DEKRA**

DEKRA Certification GmbH  
Hauptstr. 10  
42699 Solingen  
Germany  
QMS-TQM-ZM-05-01-00

**KEMA**

**PRODUCTION QUALITY ASSURANCE NOTIFICATION**

Equipment and protective systems intended for use in potentially explosive atmosphere - Directive 94/9/EC

Notification Number: KEMA 04ATEX0008, issue no. 2

This notification is issued for the equipment or protective systems or components which are described in the EC-Type Examination Certificate held in the name of the applicant.

Manufacturer: Weidmüller Interface GmbH & Co. KG  
Klingenbergstr. 16  
32758 Detmold  
Germany

Product class: Weidmüller MSP Service GmbH & Co. KG  
Klingenbergstr. 16  
32758 Detmold  
Germany

IECEx Quality System notified body number 0344 in accordance with Annex II of the Council Directive 94/9/EC of 23 March 1994, notified by the manufacturer that the production site satisfy the requirements of Annex IV and V to the Directive.

This notification is based on audit report no. NL10297456-000509 and NL10297456-000503.

Substances of the production process is part of this notification. This notification can be withdrawn if the manufacturer no longer satisfies the requirements of Annex II and V to the Directive.

This notification is valid until 14 September 2010.

According to Annex 10 (1) of the Directive 94/9/EC, the CE marking shall be accompanied by the identification number identifying the notified body concerned in the production control stage. In accordance with Annex II (2) to components shall be affixed with the CE marking.

The marking of the equipment, component or protective system shall include the identification number of KEMA: **0344**

Amsterdam, 20 October 2009  
KEMA Quality System  
*[Signature]*  
KEMA Certification Manager

Page 11 of 21

IBEXU Institut für Sicherheitstechnik GmbH  
Friedbergweg 7 · 09599 Freiberg, Germany  
T +49 (0) 3731 3863-1 · F +49 (0) 3731 2260

Authorized for contributions  
Explosion protection  
Freiberg, 13<sup>th</sup> April 2008

By order  
Dr. Lorenz  
Schaube

IBEXU Institut für Sicherheitstechnik GmbH  
Friedbergweg 7 · 09599 Freiberg, Germany  
T +49 (0) 3731 3863-1 · F +49 (0) 3731 2260

Authorized for contributions  
Explosion protection  
Freiberg, 13<sup>th</sup> April 2008

By order  
Dr. Lorenz  
Schaube

IBEXU Institut für Sicherheitstechnik GmbH  
Friedbergweg 7 · 09599 Freiberg, Germany  
T +49 (0) 3731 3863-1 · F +49 (0) 3731 2260

Authorized for contributions  
Explosion protection  
Freiberg, 13<sup>th</sup> April 2008

By order  
Dr. Lorenz  
Schaube

We cannot guarantee that there are no mistakes in the publications or software provided by us. We try our best to quickly correct errors in our printed media.

## **Weidmüller – Your partner in Industrial Connectivity**

As experienced experts we support our customers and partners around the world with products, solutions and services in the industrial environment of power, signal and data. We are at home in their industries and markets and know the technological challenges of tomorrow. We are therefore continuously developing innovative, sustainable and useful solutions for their individual needs. Together we set standards in Industrial Connectivity.

Weidmüller Interface GmbH & Co. KG  
Klingenbergstraße 16  
32758 Detmold, Germany  
T +49 5231 14-0  
F +49 5231 14-292083  
[www.weidmueller.com](http://www.weidmueller.com)

Personal support can  
be found on our website:  
[www.weidmueller.com/contact](http://www.weidmueller.com/contact)