

Circuit and Surge Protection Protection Solutions Catalog

North America

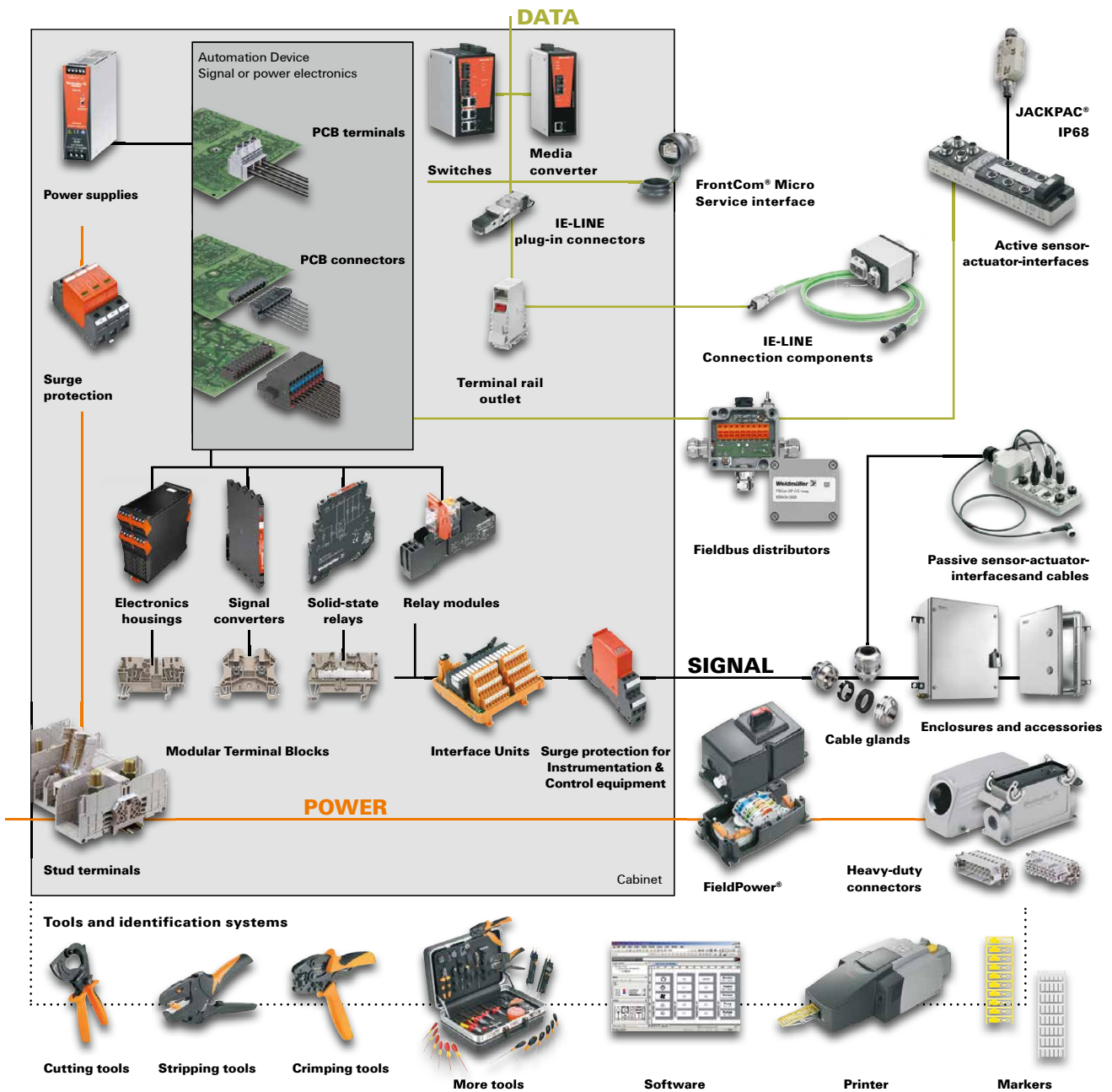

Product Portfolio



Circuit and Surge Protection

Branch Rated and Supplementary Circuit Protection	Introduction	3		
	BR Series - AC 277/480V rated	4		
	9926 Series - Model QL - AC 240V rated	11		
	9926 Series - Model QY for DC 80V/125V rated	14		
	SU Series - AC 277/480V rated	15		
	9926 Series - Model QZ - 277/480V rated	22		
	9926 Series - Ground Fault Current Interrupt	24		
	Mounting Options, Accessories, Trip Curves	25		
	CB4200 Series - Pushbutton trip/reset, AC/DC rated	27		
	CB2200 Series - Lever Type with aux contact, AC/DC rated	29		
	CB9100 Series - AC/DC rated, up to 63A AC	31		
	ESX 10-T 24 VDC - up to 12A	33		
	ESX 10-TC 12 VDC - up to 10A	41		
	SPD II 1 Series - for LV A.C. Distribution and DC Photovoltaic applications	47		
SPD II & III Series - for LV A.C. Distribution and AC device applications	52			
Electronic (DC) Circuit Protection	Quick Selection Guide	59		
	Certification	62		
	Lighting and surge protection for control and instrumentation signals	64		
	VARITECTOR SPC - Overview	66		
	VARITECTOR SPC - Surge protectors with plug / base construction.	72		
	V-TEST - hand-held tester for VSPC	112		
	VARITECTOR SSC - Overview	115		
	VARITECTOR SSC 6AN - 6 Pole surge protectors in high density terminal construction	120		
	VARITECTOR SSC 4AN - 4 Pole surge protectors in high density terminal construction	144		
	Surge Protection for Data Signals	158		
	VARITECTOR SPC EX - for hazardous locations requiring ATEX approval	159		
	V DATA	167		
	VARITECTOR SSC EX - for hazardous locations requiring ATEX approval	169		
	Lighting and Surge Protection for LV Distribution and AC - powered Devices	Introduction	171	
SD Series		178		
SLP Series		180		
MA15 Series		181		
TP48 Series		182		
VARITECTOR - Surge Protection for Control I/O Signals		Glossary	183	
		Lighting and Surge Protection for Measurement and Control Systems Intrinsically Safe Circuit (Ex Zone)		
Surge Protection - MTL				

Weidmuller Catalogs at a Glance

Catalog 1: Modular Terminal Blocks

- P-Series (Push-in)
- I-Series (IDC)
- Power Distribution Blocks and Fuse Blocks
- Stud Style (Screw clamp)
- Z-Series (Tension clamp)
- W-Series (Screw clamp)
- Multi-function Blocks

Catalog 2: PCB Terminals and Connectors

- Space Saving Technologies
- Wide Variety of Clamping Technologies
- Pitches Ranging from 3.50 mm to 15.00 mm
- Orientations Ranging from 90° to 270°

Catalog 3: RockStar® – Heavy Duty Connectors

- Inserts
- Modular System
- Housings IP65 and IP68
- Cable Glands

Catalog 4.1: Analog Signal Conditioning

- Intrinsically Safe Conditioners
- Signal Converters and Monitoring Devices
- Indicators and Configurable Displays
- Fieldbus Distribution Boxes

Catalog 4.2: Relays and Optocouplers

- Mechanical Relays
- Solid-State (Opto) Relays
- Power Solid-State Relays
- Multifunction Relays and Timers

Catalog 4.3: Power Delivery

- Power Supplies
- UPS Control Units
- Battery Back Up Units

Catalog 4.4: Surge Protection

- Surge Protection for Low-Voltage
- Surge Protection for Instrumentation and Control
- Surge Protection for Data Interfaces
- Surge Protection for Photovoltaic Systems

Catalog 5: Enclosures and Cable Glands

- Enclosures
- Cable Glands
- Cabtite (Cable Entry System)

Catalog 6: Tools

- Cutting
- Stripping
- Crimping
- Screwdrivers
- Automatic Machines
- Ferrules

Catalog 7: Marking Systems

- Terminal Markers
- Wire and Cable Markers
- Device and Equipment Markers
- Printing Systems and Software

Catalog 8: Sensor Actuator Interface

- SAI Passive Blocks
- SAI Universal
- SAI ASI
- Cables and Connectors

Catalog 9: Industrial Ethernet

- Unmanaged Switches
- Managed Switches
- Routers
- Media Converters
- SteadyTEC®
- RJ45 Connectors
- Fiber Optic Connectors
- Accessories

Catalog 10: Short Form Catalog

- Terminal Blocks
- Enclosures and Cable Glands
- Professional Tools
- Heavy Duty Connectors
- Power Supplies and Breakers
- Relays and Optos
- Analog Signal Conditioning
- Wireless and Ethernet

Catalog 11: Circuit and Surge Protection

- Surge Protection for Low Voltage
- Surge Protection for Instrumentation and Control
- Circuit Breakers and Protectors
- DIN-mountable AC Receptacles (DRAC)

Catalog 12: Wireless I/O and Ethernet Connectivity

- Wireless I/O and Ethernet
- Wireless Gateways
- Wireless Transceivers
- Antennas and Accessories

Catalog u-remote: Distributed I/O Solutions

- Field Bus Couplers
- Digital Input and Output Modules
- Analog Input and Output Modules
- Power Feed-in Modules
- Temperature Modules
- Functional Safety Modules

Branch Rated & Supplementary Circuit Protection

Weidmüller's DIN-rail mounted circuit breakers are an essential part of our Electronics portfolio, with functionality that provides protection from damaging over-currents in motor and control circuits.

A wide range of these products are UL 489 listed for branch circuit protection, and other devices are UL recognized as supplementary protectors, suitable for applications where branch circuit protection is already installed or not required.

The narrow width of many of these products helps users to minimize the size and cost of the enclosure, and the availability of accessories such as auxiliary contacts, touch protection, lockable levers and busbar assemblies provide for a safe and dependable installation.

Product	Application/Standard	AC Rating	DC Rating	No. of Poles	Width per pole (mm)	Standard Trip Curve	Comment
BR Series	Branch / UL489, CSA C22.2 No.5.02	0.5-30A / 277/480V		1, 2	17.5	C, D	Thermal-Magnetic
		1-30A / 277/480V		3	17.5	C, D	
		40-60A / 240V		1, 2, 3	17.5	C, D	
QL Series	Branch / UL489, CSA C22.2 No.5.02	0.5-25A / 240V		1, 2	13	KM	Hydraulic-Magnetic
		1-25A / 240V		3	13	KM	
QY Series	Branch / UL489, CSA C22.2 No.5.02		0.5-60A / 80V	1	13	U2	Hydraulic-Magnetic
			1-60A / 125V	1	13	U2	
			5-40A / 80V	2	13	U2	
			5-60A / 125V	2	13	U2	
SU Series	Supplementary / UL1077, CSA C22.2 No. 235	0.5-60A / 277/480V		1, 2	17.5	C, D	Thermal-Magnetic
		1-60A / 277/480V		3	17.5	C, D	
OZ Series	Supplementary / UL1077, CSA C22.2 No. 235	1-60A / 277/480V		1,2	13	2	Hydraulic-Magnetic
		10-60A / 277/480V		3	13	2	
GFCI Series	Supplementary / UL1077, CSA C22.2 No. 235	5-50A / 240V		2	13	2	Hydraulic-Magnetic
CB4200 Series	Supplementary / UL1077, CSA C22.2 No. 235	0.05-16A / 250V	0.05-16A / 65V	1, 2	12.5	M1	Thermal-Magnetic/Push Button trip/reset
CB2200 Series	Supplementary / UL1077, CSA C22.2 No. 235	0.1-32A / 277/480V	0.1-32A / 65V	1, 2	12.5	M1	Thermal-Magnetic/Integral NO or NC aux contact
		0.1-20A / 277/480V	0.1-20A / 65V	3	12.5	M1	
9100 Series	Supplementary / UL1077, CSA C22.2 No. 235	0.5-63A / 277V	0.5-50A / 50V	1	18	M1	Thermal-Magnetic
		0.5-63A / 480V	0.5-50A / 110V	2	18	M1	
		0.5-63A / 480V		3	18	M1	

Branch Rated Circuit Protection



Compared to traditional fuse installation, the UL489/CSA C22.2 No.5-02 compliant circuit breakers listed here assist with the complex task of selecting correct types and characteristics and offer a less bulky installation solution. Our range of miniature, molded-case circuit breakers, in combination with our accessories for factory or on-site installation, offer enhanced control and monitoring capabilities. Installation kits include all parts and instructions to make the on-site job easy.

We supply UL489/CSA C22.2 No.5-02 compliant 1, 2 and 3-pole-type circuit breakers from 0.5 to 60 Ampere and with type C and D characteristics.

Attachments such as neutral switches, auxiliary contacts and shunt trips are also available for this system. All accessories for modern busbar installations are available in compliance with the relevant UL standards.

Branch Rated Circuit Breakers

Branch Rated Circuit Breakers

Our range of UL489/CSA C22.2 No.5-02 branch rated circuit breakers in combination with our accessories for factory or on-site installation offer enhanced control and monitoring capabilities. Installation kits include all parts and instructions to make the on-site job easy.

Single Pole - D Curve

Current Ratings (amps)	Description	Part No.	Single Pole - C Curve	Part No.
0.5	Branch / 1P Cct Brkr / D Curve / 0.5A	BR1D05AC	Branch / 1P Cct Brkr / C Curve / 0.5A	BR1C05AC
1	Branch / 1P Cct Brkr / D Curve / 1A	BR1D1AC	Branch / 1P Cct Brkr / C Curve / 1A	BR1C1AC
2	Branch / 1P Cct Brkr / D Curve / 2A	BR1D2AC	Branch / 1P Cct Brkr / C Curve / 2A	BR1C2AC
3	Branch / 1P Cct Brkr / D Curve / 3A	BR1D3AC	Branch / 1P Cct Brkr / C Curve / 3A	BR1C3AC
5	Branch / 1P Cct Brkr / D Curve / 5A	BR1D5AC	Branch / 1P Cct Brkr / C Curve / 5A	BR1C5AC
10	Branch / 1P Cct Brkr / D Curve / 10A	BR1D10AC	Branch / 1P Cct Brkr / C Curve / 10A	BR1C10AC
15	Branch / 1P Cct Brkr / D Curve / 15A	BR1D15AC	Branch / 1P Cct Brkr / C Curve / 15A	BR1C15AC
20	Branch / 1P Cct Brkr / D Curve / 20A	BR1D20AC	Branch / 1P Cct Brkr / C Curve / 20A	BR1C20AC
25	Branch / 1P Cct Brkr / D Curve / 25A	BR1D25AC	Branch / 1P Cct Brkr / C Curve / 25A	BR1C25AC
30	Branch / 1P Cct Brkr / D Curve / 30A	BR1D30AC	Branch / 1P Cct Brkr / C Curve / 30A	BR1C30AC
40	Branch / 1P Cct Brkr / D Curve / 40A	BR1D40AC	Branch / 1P Cct Brkr / C Curve / 40A	BR1C40AC
50	Branch / 1P Cct Brkr / D Curve / 50A	BR1D50AC	Branch / 1P Cct Brkr / C Curve / 50A	BR1C50AC
60	Branch / 1P Cct Brkr / D Curve / 60A	BR1D60AC	Branch / 1P Cct Brkr / C Curve / 60A	BR1C60AC

Double Pole - D Curve

Current Ratings (amps)	Description	Part No.	Double Pole - C Curve	Part No.
0.5	Branch / 2P Cct Brkr / D Curve / 0.5A	BR2D05AC	Branch / 2P Cct Brkr / C Curve / 0.5A	BR2C05AC
1	Branch / 2P Cct Brkr / D Curve / 1A	BR2D1AC	Branch / 2P Cct Brkr / C Curve / 1A	BR2C1AC
2	Branch / 2P Cct Brkr / D Curve / 2A	BR2D2AC	Branch / 2P Cct Brkr / C Curve / 2A	BR2C2AC
5	Branch / 2P Cct Brkr / D Curve / 5A	BR2D5AC	Branch / 2P Cct Brkr / C Curve / 5A	BR2C5AC
10	Branch / 2P Cct Brkr / D Curve / 10A	BR2D10AC	Branch / 2P Cct Brkr / C Curve / 10A	BR2C10AC
15	Branch / 2P Cct Brkr / D Curve / 15A	BR2D15AC	Branch / 2P Cct Brkr / C Curve / 15A	BR2C15AC
20	Branch / 2P Cct Brkr / D Curve / 20A	BR2D20AC	Branch / 2P Cct Brkr / C Curve / 20A	BR2C20AC
25	Branch / 2P Cct Brkr / D Curve / 25A	BR2D25AC	Branch / 2P Cct Brkr / C Curve / 25A	BR2C25AC
30	Branch / 2P Cct Brkr / D Curve / 30A	BR2D30AC	Branch / 2P Cct Brkr / C Curve / 30A	BR2C30AC
40	Branch / 2P Cct Brkr / D Curve / 40A	BR2D40AC	Branch / 2P Cct Brkr / C Curve / 40A	BR2C40AC
50	Branch / 2P Cct Brkr / D Curve / 50A	BR2D50AC	Branch / 2P Cct Brkr / C Curve / 50A	BR2C50AC
60	Branch / 2P Cct Brkr / D Curve / 60A	BR2D60AC	Branch / 2P Cct Brkr / C Curve / 60A	BR2C60AC

Triple Pole - D Curve

Current Ratings (amps)	Description	Part No.	Triple Pole - C Curve	Part No.
1	Branch / 3P Cct Brkr / D Curve / 1A	BR3D1AC	Branch / 3P Cct Brkr / C Curve / 1A	BR3C1AC
2	Branch / 3P Cct Brkr / D Curve / 2A	BR3D2AC	Branch / 3P Cct Brkr / C Curve / 2A	BR3C2AC
5	Branch / 3P Cct Brkr / D Curve / 5A	BR3D5AC	Branch / 3P Cct Brkr / C Curve / 5A	BR3C5AC
10	Branch / 3P Cct Brkr / D Curve / 10A	BR3D10AC	Branch / 3P Cct Brkr / C Curve / 10A	BR3C10AC
15	Branch / 3P Cct Brkr / D Curve / 15A	BR3D15AC	Branch / 3P Cct Brkr / C Curve / 15A	BR3C15AC
20	Branch / 3P Cct Brkr / D Curve / 20A	BR3D20AC	Branch / 3P Cct Brkr / C Curve / 20A	BR3C20AC
25	Branch / 3P Cct Brkr / D Curve / 25A	BR3D25AC	Branch / 3P Cct Brkr / C Curve / 25A	BR3C25AC
30	Branch / 3P Cct Brkr / D Curve / 30A	BR3D30AC	Branch / 3P Cct Brkr / C Curve / 30A	BR3C30AC
40	Branch / 3P Cct Brkr / D Curve / 40A	BR3D40AC	Branch / 3P Cct Brkr / C Curve / 40A	BR3C40AC
50	Branch / 3P Cct Brkr / D Curve / 50A	BR3D50AC	Branch / 3P Cct Brkr / C Curve / 50A	BR3C50AC
60	Branch / 3P Cct Brkr / D Curve / 60A	BR3D60AC	Branch / 3P Cct Brkr / C Curve / 60A	BR3C60AC

Note: Additional current ratings available. Contact your local Weidmüller representative.



Accessories for Branch Rated Circuit Breakers

Module	Type of Contact	Contacts	Weight g / Each	Packing Unit	Part No.
Auxiliary contact, for mounting on the right					
1/2	1 auxiliary contact	1NO	35	6	BAU10
1/2	2 auxiliary contacts	1NO + 1NC	40	6	BAU11

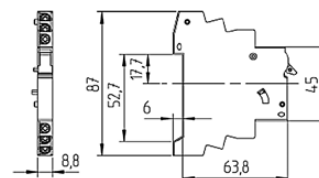
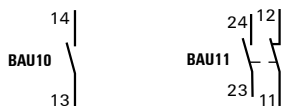

Standards	UL489 and CSA C22.2 No. 5-02	
Rated operating currents	10 A / 240 V AC	3 A / 110 V DC
	1 A / 220 V DC	
Minimum contact load	1 mA at 24 V DC	
Conductor cross sections		
Type of conductor *)	min.	max.
Single wire	1.0 mm ² (AWG18)	2.5 mm ² (AWG14)
Stranded wire	1.0 mm ² (AWG18)	1.5 mm ² (AWG16)
Stranded wire with ferrule	1.0 mm ² (AWG18)	1.5 mm ² (AWG16)
Torque	max. 0.8 Nm (7 lb.in)	

*) Stripped length 8 - 9 mm () values in brackets = measurement units for North America

Rated Current I _n A	Rated Voltage V AC	Test Currents* Electromagnetic		Weight g / Each	Packing Unit	Part No.
		Not Tripping I _n A	Tripping I _n A			
Neutral switch						
0.3 - 32	277/480	400	700	165	6	BNS32A
40 - 63	240	630	1000	165	6	BNS63A

* additional electromagnetic protection

Module	Rated Operating Voltage	Max. operating current at Un (t < 10 ms)	Weight g / Each	Packing Unit	Part No.
Shunt trip, for mounting on the right or left					
0.3 - 32	110 - 240 V UC, 277 V AC	0.25 A at 110 V	110	5	BST110V

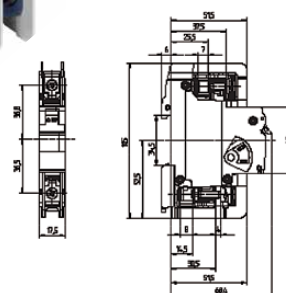

Lock-off/Lock-on device

Weight g / Each	Packing Unit	Part No.
2	10	LD10



Branch Rated Circuit Breakers

Accessories for Branch Rated Circuit Breakers

Mounting Instructions of Accessories

Applies to BNS... and BST:

The accessory devices BNS... and BST can be installed on the right or left.

Mounting

1. Bring the blue knobs of all devices into the "OFF" position
2. Remove grey cover from the switching device and attachment
3. Insert drive plate between the switching device and BNS... or BST
4. Insert connecting pin into the knob (insertion depth approx. 7 mm)
5. Combine switching device and BNS... or BST
6. Screw the devices together (observe correct screw length)

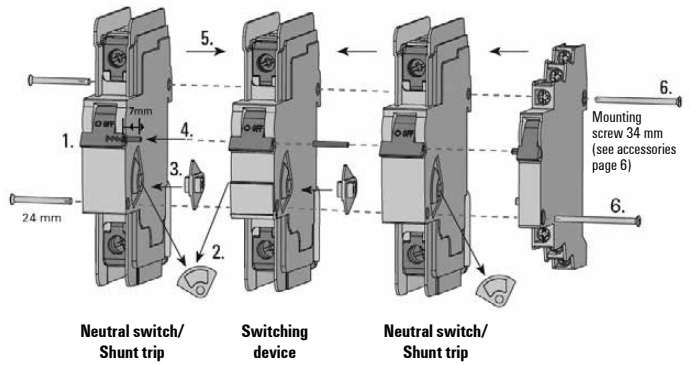

Applies to BAU...

The auxiliary contact BAU... can only be installed on the right.

Installation

1. Flick the blue switches of all devices to the "OFF" position
2. Remove the grey cover from the switching device and attachment
3. Combine switching device and BAU...
4. Insert connection screws and connect the two devices by turning the screws 90°
5. After installation, close and open to check correct operation

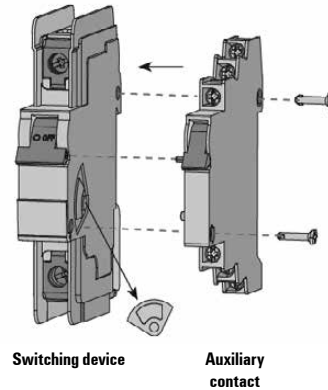

Applies to all switching devices

BNS..., BST and BAU...

The load and mains can be connected into either the top or bottom (Line/Load Reversible).

Design of the terminals

- Optical detection of screw position
- Increased breaking resistance if the screwdriver becomes jammed
- Universal connecting terminals, suitable for connecting all known cable lugs such as ring or forked cable lugs and pin terminals
- Ring cable lugs can be connected by opening the flap and removing the connecting screw
- Can also be used for applications that require ring cable lugs (e.g. nuclear power stations)
- DIN EN 50274, VDE 0660-514 compliant protection against contact with live parts is fully guaranteed

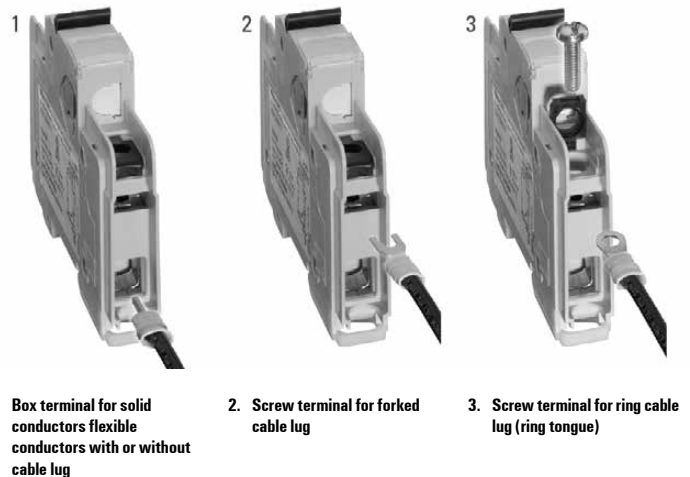

Busbar and Accessories for Branch Rated Circuit Breakers (UL489/CSA C22.2 No.5-02)

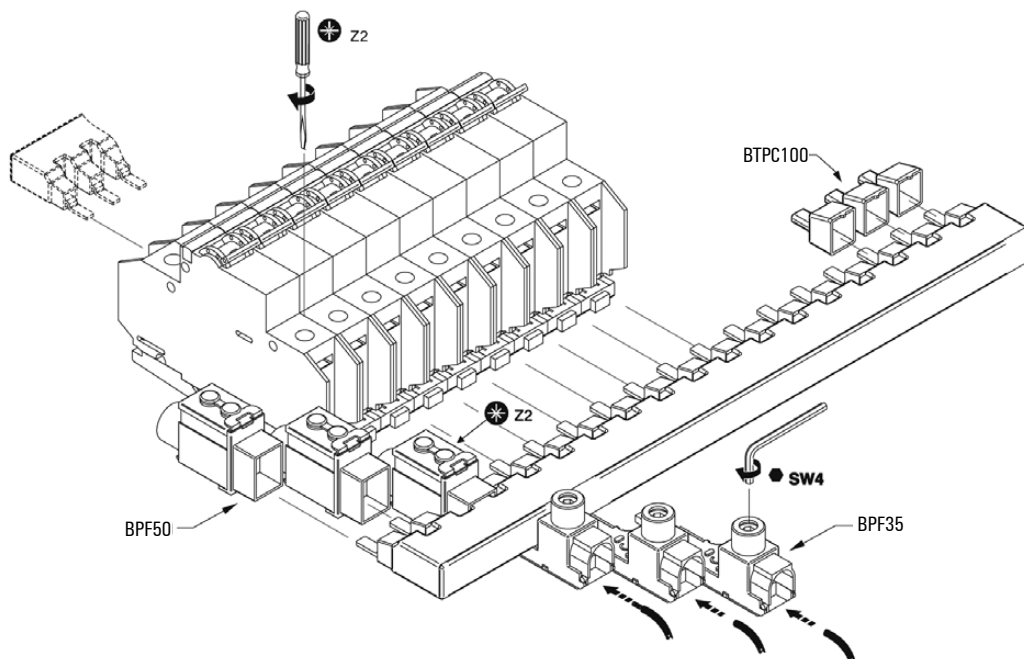

- Designed for a load up to 115A
- suitable accessories as connection terminals and contact protection
- Busbars may not be shortened

Description	Part No.
Busbar/Branch Protection/1ph/6Poles	BB106
Busbar/Branch Protection/1ph/12Poles	BB112
Busbar/Branch Protection/1ph/18Poles	BB118
Busbar/Branch Protection/1ph/12Poles	BB206
Busbar/Branch Protection/2ph/12Poles	BB212
Busbar/Branch Protection/2ph/18Poles	BB218
Busbar/Branch Protection/3ph/6Poles	BB306
Busbar/Branch Protection/3ph/12Poles	BB312
Busbar/Branch Protection/3ph/18Poles	BB318
PwrFeed Term - 35mm ²	BPF35
PwrFeed Term - 50mm ²	BPF50
Touch Protection 3Caps	BTPC100



Mounting screw 34 mm

to connect the auxiliary contact and shunt trip or neutral switch to the switching devices

Packing Unit	Part No.
10 pieces	MS34



Touch-protection caps

to cover the connecting screws on the switching devices, neutral switches and shunt trips for increased touch protection

Packing Unit	Part No.
100 pieces	TPC

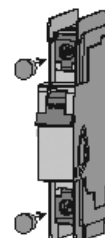

Branch Rated Circuit Breakers

Technical Data for Branch Rated Circuit Breakers (AC)

Characteristic *		C	D
Application		Lighting Wiring protection Control circuits Business equipment Appliances Motors low inrush	Transformers Power supplies Heaters Motors high inrush Reactive load
Number of poles		1 - 3; 1 + N; 3 + N	
Standards		UL489 and CSA-22.2 Nr. 5-09	
Interrupting capacity		10 kA	
Back-up fuse ≤ 10 kA interrupting capacity		none	
Rated voltage AC 50/60 Hz 0.3 - 32 A		277 / 480 V	
Rated voltage AC 50/60 Hz 40 - 63 A		240 V	
Rated current range		0.5 - 60 A	0.5 - 60 A
Test currents	Thermal not tripping I ₁ (A) > 1 h	1.05 x I _n	1.05 x I _n
	Thermal tripping I ₂ (A) < 1 h	1.35 x I _n	1.35 x I _n
	Electromagnetic not tripping I ₄ (A) > 0.1 s	5 x I _n	10 x I _n
	Electromagnetic tripping I ₅ (A) < 0.1 s	10 x I _n	16 x I _n
Reference calibration temperature of the thermal tripping		40 °C Influence of the ambient temperature on the thermal release: Decrease of the current values with higher ambient temperature and increase with lower temperatures of approximately 5 % per 10 °C difference in temperature	
Frequency range of the electromagnetic trip		16 ⅔ to 60 Hz With higher frequencies, the electromagnetic tripping values increase by approximately a factor of 1.1 at 100 Hz; 1.2 at 200 Hz; 1.3 at 300 Hz; 1.4 at 400 Hz; 1.5 for DC	
Ambient temperature		-25 °C to +55 °C	
Storage temperature		-40 °C to +70 °C	
Device depth according to DIN 43880		68 mm	
Mechanical life		10,000 switching cycles (ON / OFF)	
Protection cover		Finger safe and safe to back of hand according to DIN EN 50274, VDE 0660-514	
Degree of protection acc. EN / IEC 60529		IP20	
Installation position		any	
Mounting		DIN-rail according to DIN EN 60715 35 mm	
Lockability		The handle can be secured against manual switching in the on and off position by a lead seal	
Climatic resistance		Humid heat constant according to DIN EN 60068-2-78 Humid heat cycle according to DIN EN 60068-2-30	
Vibration resistance		> 15 g according to DIN EN 60068-2-59 during a load with I ₁	
Resistance to mechanical shocks		25 g 11 ms	
Approvals - BR... items		cULus marking, UL file E359964, ref standards UL489 and CAN/CSA-C22.2 No. 5 (2002)	
Approvals - BAU..., BNS..., BST... items		cULus marking, UL file E362204, ref standards UL489 and CAN/CSA-C22.2 No. 5 (2002)	
Approvals - BB..., BPF..., BTPC... items		pending	

* Other switching devices in B and Z characteristics available on request

Interrupting capacity acc. to IEC 60947-2, DIN EN 60947-2

Characteristic *	C, D		
1pole	0.5 - 60 A	240 V	15 kA
2pole / 3pole	0.5 - 60 A	415 V	15 kA
2pole / 3pole	40 - 60 A	415 V	10 kA

Technical Data for Branch Rated Circuit Breakers (AC)

Type of conductor *)	Conductor Cross Sections			
	Box Terminal Bottom		Box Terminal Top	
Single wire	max. 35 mm ² (AWG2)	min. 1.0 mm ² (AWG18)	max. 25 mm ² (AWG3)	min. 1.0 mm ² (AWG18)
Multiple wire	35 mm ² (AWG2)	16 mm ² (AWG6)	25 mm ² (AWG3)	16 mm ² (AWG6)
Stranded wire	25 mm ² (AWG3)	1.0 mm ² (AWG18)	16 mm ² (AWG6)	1.0 mm ² (AWG18)
Stranded wire with ferrule	16 mm ² (AWG6)	1.0 mm ² (AWG18)	16 mm ² (AWG6)	1.0 mm ² (AWG18)
Busbar cable lug	up to 3 mm thickness		up to 1.5 mm thickness	
Combined, conductor and busbar or cable lug	up to 35 mm ² and up to 2 mm thickness		not possible	
Torque	max. 2.5 Nm (22.2 lb.in)			

Dimension Diagrams in mm (in.)

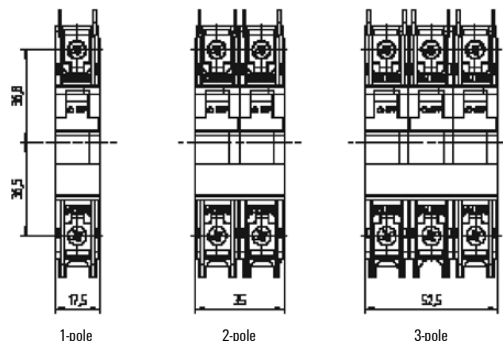

*) Stripped lengths: 12 - 14 mm at the bottom, 10 - 12 mm at the top
 () values in brackets = measurement units for North America Copper conductor with sheath insulation for 60/75 °C

Internal Resistance for Product Range BR

Rated Current [A]	Trip Characteristic	
	C [Ohm]	D [Ohm]
0.3	16.8620	16.8620
0.5	6.8540	6.0009
1.0	1.7000	1.7560
1.6	0.5870	0.5870
2.0	0.4190	0.4190
3.0	0.2020	0.2020
4.0	0.1090	0.1090
5.0	0.0654	0.0654
6.0	0.0528	0.0491
8.0	0.0278	0.0240
10	0.0216	0.0187
12	0.0084	0.0085
13	0.0084	0.0085
15/16	0.0085	0.0076
20	0.0067	0.0064
25	0.0050	0.0041
30/32	0.0032	0.0027
40	0.0025	0.0022
50	0.0019	0.0018
60	0.0018	0.0017

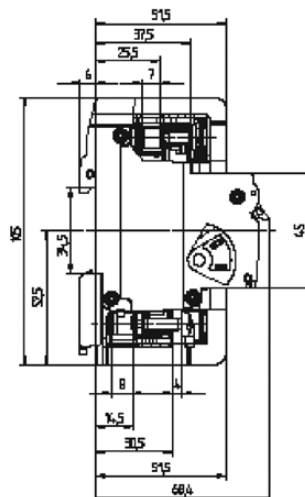

Curves for Branch Rated Circuit Breakers

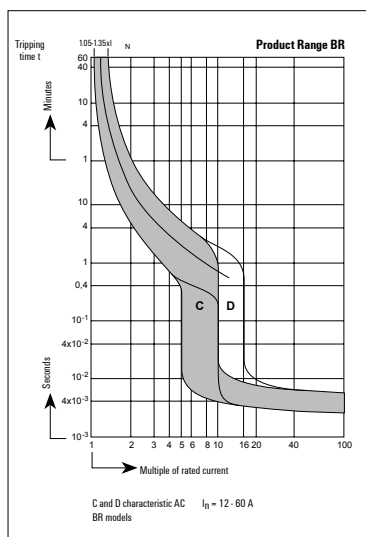
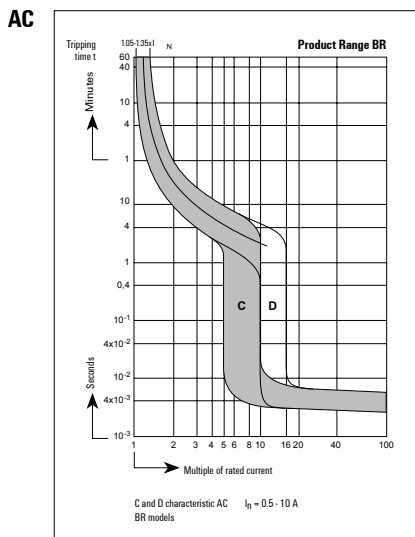

9926 Series Branch Circuit Breakers and Supplementary Protectors



Weidmüller's range of industrial, DIN-rail mounted circuit breakers are part of our broad electronics portfolio, which provides isolation and protection solutions for automation control systems. Compared with traditional fused protection, these compact circuit breakers can be closely tailored to the application, in order to simplify control and minimize equipment downtime in the event of a fault.

Product ratings and mechanical construction are designed to provide the high levels of reliability expected from automation and control equipment installed on capital plant, and specifications conform to recognized international standards.

Overview of 9926 Series

Model QL

- AC Branch-rated circuit breakers
- UL489 Listed, CSA, VDE, CE conformity
- 1, 2 and 3 pole units (NEW)
- Ratings up to 240V/25A

Model QY

- DC Branch-rated circuit breakers
- UL489A Listed, VDE, CE conformity
- 1 and 2 pole units (NEW)
- Ratings up to 125V/60A

Model QZ

- AC Supplementary circuit breakers
- UL1077 Recognized, VDE, CE conformity, CSA
- 1, 2 and 3 pole units
- Ratings up to 277/480V/60A

Model GFCI

- AC Supplementary circuit breakers
- UL1077 and UL1053 Recognized, CE conformity
- 1 pole (+N) units
- Ratings up to 240V/63A

9926 Series Features

- For industrial AC and DC installations
- Models either for branch applications cULus (UL489/CSA C22.2 No 5.02) approvals or supplemental cURus/UL1077 approved /CSA C22.2 No. 235.
- Single and multi-pole models, with auxiliary/trip options
- Trip point unaffected by ambient temperature changes
- Variety of trip characteristics available, to suit equipment protected
- Narrow width on mounting rail – 13mm per pole
- GFCI models with standard ratings up to 240V/50A
- Full set of approved accessories, such as busbars, power lugs, lock-out handles

9926 Series Branch Circuit Breakers (AC)

Circuit Breakers Hydraulic Magnetic Type

- 1, 2 and 3 pole versions
- 120/240 VAC, 50/60 Hz
- Up to 25A
- Just 13 mm wide, per pole
- Mounts on 35mm DIN-rail
- cULus listed according to UL489 CSA C22.2 No. 5.02, CE, VDE

9926 Series Single Pole



9926 Series Double Pole



9926 Series Triple Pole



Technical Data	
Voltage	120/240 VAC, 50/60Hz
Current minimum	0.5A
Current maximum	25A
Interrupting capacity	10,000A
Dielectric strength	1500V, 50/60Hz
Insulation resistance	100 MΩ
Operating Life	10000 mechanical operations
Operating temperature	-40...+65°C
Wire size*	
*0.5-15A:	14AWG min., 10AWG max.
20-25A:	10AWG min.
Torque	20 in.-lb

Accessories

Type	Part No.
Bus-bar (1 pole, insulated, 1 m)	67101904
Bus-bar (2 pole, insulated, 1 m)	67101972
Bus-bar end cap, 1 pole	67101973
Bus-bar end cap, 2 pole	67101974
Power lug, straight (14 mm)	67101960
Power lug, 90° (14 mm)	67101961
Power lug, straight (32 mm)	67102480
Power lug, 90° (32 mm)	67102479
Lock-out handle	67101913

*Wire sizes: gauges specified are the minimum allowable as per CSA and UL standards.

The 9926 circuit breakers do not have provisions for marking tags. A possible solution is to cut the adhesive SchS2 tag rail to length (approximately 20 mm on a single pole unit so the current rating remains visible or approximately 30 mm on a two pole unit). The SchS2 accepts DEK, WS and ESG 8/17 marking tags. The part number for adhesive SchS2 is 172060000.

See Trip Curves 1, 3, 9, KM, OP - Page 26

Type: Single Pole (up to 120 VAC)			
Current Ratings (amps)	Description	Part No.	
0.5	QL-1-13-DM-KM-0.5	9926251000	
1	QL-1-13-DM-KM-01	9926251001	
2	QL-1-13-DM-KM-02	9926251002	
3	QL-1-13-DM-KM-03	9926251003	
4	QL-1-13-DM-KM-04	9926251004	
5	QL-1-13-DM-KM-05	9926251005	
6	QL-1-13-DM-KM-06	9926251006	
7	QL-1-13-DM-KM-07	9926251007	
8	QL-1-13-DM-KM-08	9926251008	
10	QL-1-13-DM-KM-10	9926251010	
13	QL-1-13-DM-KM-13	9926251013	
15	QL-1-13-DM-KM-15	9926251015	
16	QL-1-13-DM-KM-16	9926251016	
20	QL-1-13-DM-KM-20	9926251020	
25	QL-1-13-DM-KM-25	9926251025	

Type: Double Pole (up to 240 VAC)			
Current Ratings (amps)	Description	Part No.	
0.5	QL-2-13-DM-KM-0.5	9926252000	
1	QL-2-13-DM-KM-01	9926252001	
2	QL-2-13-DM-KM-02	9926252002	
3	QL-2-13-DM-KM-03	9926252003	
4	QL-2-13-DM-KM-04	9926252004	
5	QL-2-13-DM-KM-05	9926252005	
6	QL-2-13-DM-KM-06	9926252006	
7	QL-2-13-DM-KM-07	9926252007	
8	QL-2-13-DM-KM-08	9926252008	
10	QL-2-13-DM-KM-10	9926252010	
13	QL-2-13-DM-KM-13	9926252013	
15	QL-2-13-DM-KM-15	9926252015	
16	QL-2-13-DM-KM-16	9926252016	
20	QL-2-13-DM-KM-20	9926252020	
25	QL-2-13-DM-KM-25	9926252025	

Type: Triple Pole (up to 240 VAC)			
Current Ratings (amps)	Description	Part No.	
1	QL-3(13)-DM-KM-1A	9926253001	
2	QL-3(13)-DM-KM-2A	9926253002	
5	QL-3(13)-DM-KM-5A	9926253005	
10	QL-3(13)-DM-KM-10A	9926253010	
15	QL-3(13)-DM-KM-15A	9926253015	
20	QL-3(13)-DM-KM-20A	9926253020	
25	QL-3(13)-DM-KM-25A	9926253025	

Dimension Diagrams in mm (in.)

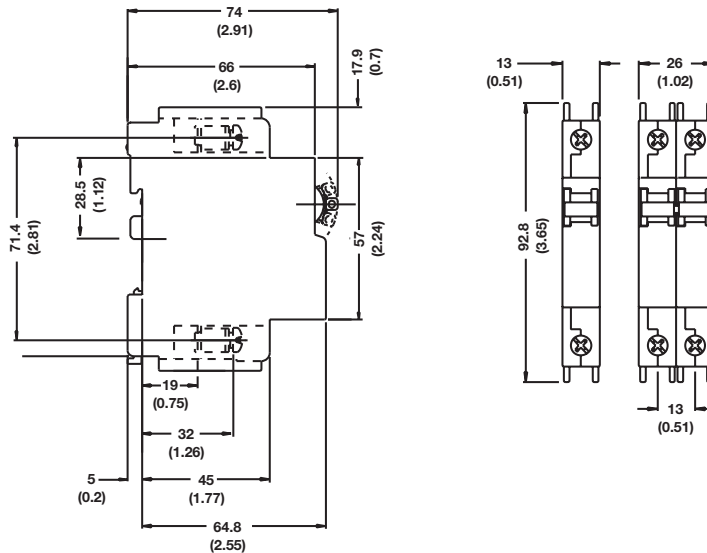

9926 Series Branch Circuit Breakers (AC)

Circuit Breakers with Auxiliary switch, Trip alarm, Combination of both

- AC voltages (120/240V)
- 1, 2 and 3 pole versions
- cULus listed according to UL489 and C22.2 No. 5.02, CE, VDE
- Factory fitted auxiliary or trip alarm
 - Compact 6.5mm width, per pole
 - Attached to right hand side of circuit breaker

Technical Data	
Voltage	120/240 VAC, 50/60Hz
Current minimum	0.5A
Current maximum	25A
Interrupting capacity	10,000A
Dielectric strength	1500V, 50/60Hz
Insulation resistance	100 MΩ
Operating Life	10000 mechanical operations
Operating temperature	-40...+65°C
Wire size*	
0.5-15A:	14AWG min., 10AWG max.
20-25A:	10AWG min.
Torque	20 in.-lb

Approval	
cULus listed according to UL489 and C22.2 No. 5.02, CE, VDE	

*UL 489 listed (5A, 250 VAC; 0.5A, 80 VDC Auxiliary; 0.5A, 125 VDC Trip Alarm)
 IEC 60947-5-1 Approved (5A, 250 VAC; 0.5A, 110 VDC Auxiliary; 0.5A, 125 VDC Trip Alarm)

*Wire sizes: gauges specified are the minimum allowable as per CSA and UL standards.

The 9926 circuit breakers do not have provisions for marking tags. A possible solution is to cut the adhesive SchS2 tag rail to length (approximately 20 mm on a single pole unit so the current rating remains visible or approximately 30 mm on a two pole unit). The SchS2 accepts DEK, WS and ESG 8/17 marking tags. The part number for adhesive SchS2 is 172060000.

Dimension Diagrams in mm (in.)

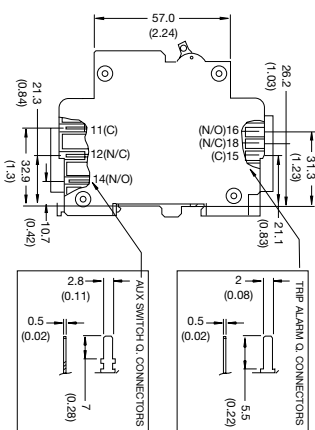

See Trip Curves 1, 3, 9, KM, OP - Page 26

9926 Series Single Pole w/ Auxiliary Contact'



Type: Single Pole Trip (up to 120 VAC)			
Current Ratings (amps)	Description	Part No.	
1	QL-A-1-13-DM-KM-1	9926261001	
2	QL-A-1-13-DM-KM-2	9926261002	
5	QL-A-1-13-DM-KM-5	9926261005	
10	QL-A-1-13-DM-KM-10	9926261010	
15	QL-A-1-13-DM-KM-15	9926261015	
20	QL-A-1-13-DM-KM-20	9926261020	
25	QL-A-1-13-DM-KM-25	9926261025	

9926 Series Double Pole w/ Auxiliary Contact'



Type: Double Pole Aux (up to 240 VAC)			
Current Ratings (amps)	Description	Part No.	
1	QL-A-2-13-DM-KM-1	9926262001	
2	QL-A-2-13-DM-KM-2	9926262002	
5	QL-A-2-13-DM-KM-5	9926262005	
10	QL-A-2-13-DM-KM-10	9926262010	
15	QL-A-2-13-DM-KM-15	9926262015	
20	QL-A-2-13-DM-KM-20	9926262020	
25	QL-A-2-13-DM-KM-25	9926262025	

9926 Series Triple Pole w/ Auxiliary Contact'



Type: Triple Pole Aux (up to 240 VAC)			
Current Ratings (amps)	Description	Part No.	
1	QL-A-3(13)-DM-KM-1A	9926263001	
2	QL-A-3(13)-DM-KM-2A	9926263002	
5	QL-A-3(13)-DM-KM-5A	9926263005	
10	QL-A-3(13)-DM-KM-10A	9926263010	
15	QL-A-3(13)-DM-KM-15A	9926263015	
20	QL-A-3(13)-DM-KM-20A	9926263020	
25	QL-A-3(13)-DM-KM-25A	9926263025	

9926 Series Single Pole Trip (Alarm Contact)



Type: Single Pole Trip (up to 120 VAC)			
Current Ratings (amps)	Description	Part No.	
1	QL-T-1-13-DM-KM-1	9926271001	
2	QL-T-1-13-DM-KM-2	9926271002	
5	QL-T-1-13-DM-KM-5	9926271005	
10	QL-T-1-13-DM-KM-10	9926271010	
15	QL-T-1-13-DM-KM-15	9926271015	
20	QL-T-1-13-DM-KM-20	9926271020	
25	QL-T-1-13-DM-KM-25	9926271025	

9926 Series Double Pole Trip (Alarm Contact)



Type: Double Pole Trip (up to 240 VAC)			
Current Ratings (amps)	Description	Part No.	
1	QL-T-2-13-DM-KM-1	9926272001	
2	QL-T-2-13-DM-KM-2	9926272002	
5	QL-T-2-13-DM-KM-5	9926272005	
10	QL-T-2-13-DM-KM-10	9926272010	
15	QL-T-2-13-DM-KM-15	9926272015	
20	QL-T-2-13-DM-KM-20	9926272020	
25	QL-T-2-13-DM-KM-25	9926272025	

9926 Series Triple Pole Trip (Alarm Contact)



Type: Triple Pole Trip (up to 240 VAC)			
Current Ratings (amps)	Description	Part No.	
1	QL-T-3(13)-DM-KM-1A	9926273001	
2	QL-T-3(13)-DM-KM-2A	9926273002	
5	QL-T-3(13)-DM-KM-5A	9926273005	
10	QL-T-3(13)-DM-KM-10A	9926273010	
15	QL-T-3(13)-DM-KM-15A	9926273015	
20	QL-T-3(13)-DM-KM-20A	9926273020	
25	QL-T-3(13)-DM-KM-25A	9926273025	

9926 Series Single Pole Combination (Auxiliary & Alarm Contact)'



Type: Triple Pole (up to 120 VAC)			
Current Ratings (amps)	Description	Part No.	
1	QL-AT-1-13-DM-KM-1	9926281001	
2	QL-AT-1-13-DM-KM-2	9926281002	
5	QL-AT-1-13-DM-KM-5	9926281005	
10	QL-AT-1-13-DM-KM-10	9926281010	
15	QL-AT-1-13-DM-KM-15	9926281015	
20	QL-AT-1-13-DM-KM-20	9926281020	
25	QL-AT-1-13-DM-KM-25	9926281025	

9926 Series Double Pole Combination (Auxiliary & Alarm Contact)'



Type: Double Pole Combo (up to 240 VAC)			
Current Ratings (amps)	Description	Part No.	
1	QL-AT-2-13-DM-KM-1	9926282001	
2	QL-AT-2-13-DM-KM-2	9926282002	
5	QL-AT-2-13-DM-KM-5	9926282005	
10	QL-AT-2-13-DM-KM-10	9926282010	
15	QL-AT-2-13-DM-KM-15	9926282015	
20	QL-AT-2-13-DM-KM-20	9926282020	
25	QL-AT-2-13-DM-KM-25	9926282025	

9926 Series Triple Pole Combination (Auxiliary & Alarm Contact)'



Type: Triple Pole Combo (up to 240 VAC)			
Current Ratings (amps)	Description	Part No.	
1	QL-AT-3(13)-DM-KM-1A	9926283001	
2	QL-AT-3(13)-DM-KM-2A	9926283002	
5	QL-AT-3(13)-DM-KM-5A	9926283005	
10	QL-AT-3(13)-DM-KM-10A	9926283010	
15	QL-AT-3(13)-DM-KM-15A	9926283015	
20	QL-AT-3(13)-DM-KM-20A	9926283020	
25	QL-AT-3(13)-DM-KM-25A	9926283025	

9926 Series Branch Circuit Breakers - DC Version

Circuit Breakers Hydraulic Magnetic Type

- Single and double pole versions
- U2 trip curve for general purpose applications
- 80 and 125 VDC
- Up to 60A
- Just 13 mm wide, per pole
- Mounts on 35 mm DIN-rail
- UL 489A listed
- VDE

9926 Series Single Pole (80 VDC)



9926 Series Single Pole (125 VDC)



Technical Data	
Voltage	120/240 VAC, 50/60Hz
Current minimum	0.5A
Current maximum	60A
Interrupting capacity	10,000A
Dielectric strength	1500V, 50/60Hz
Insulation resistance	100 MΩ
Operating Life	10000 mechanical operations
Operating temperature	-40...+65°C
Wire size*	
1-15A:	14AWG min., 10AWG max.
20-25A:	10AWG min.
Torque	20 in.-lb

Approval	
UL listed to UL489	

*Wire sizes: gauges specified are the minimum allowable as per CSA and UL standards.

The 9926 circuit breakers do not have provisions for marking tags. A possible solution is to cut the adhesive SchS2 tag rail to length (approximately 20 mm on a single pole unit so the current rating remains visible or approximately 30 mm on a two pole unit). The SchS2 accepts DEK, WS and ESG 8/17 marking tags. The part number for adhesive SchS2 is **1720600000**.

Type	Part No.
Bus-bar (1 pole, insulated, 1 m)	67101904
Bus-bar end cap, 1 pole	67101973
Power lug, straight (14 mm)	67101960
Power lug, 90° (14 mm)	67101961
Power lug, straight (32 mm)	67102480
Power lug, 90° (32 mm)	67102479
Lock-out handle	67101913

See Trip Curves 1, 9, OP, U2 - Page 26

Type: Single Pole (80 VDC)			
Current Ratings (amps)	Description	Part No.	
0.5	QY-1-13-DM-U2-0.5	9926251900	
1	QY-1-13-DM-U2-01	9926251901	
2	QY-1-13-DM-U2-02	9926251902	
3	QY-1-13-DM-U2-03	9926251903	
4	QY-1-13-DM-U2-04	9926251904	
5	QY-1-13-DM-U2-05	9926251905	
10	QY-1-13-DM-U2-10	9926251910	
15	QY-1-13-DM-U2-15	9926251915	
20	QY-1-13-DM-U2-20	9926251920	
25	QY-1-13-DM-U2-25	9926251925	
30	QY-1-13-DM-U2-30	9926251930	
35	QY-1-13-DM-U2-35	9926251935	
40	QY-1-13-DM-U2-40	9926251940	
45	QY-1-13-DM-U2-45	9926251945	
50	QY-1-13-DM-U2-50	9926251950	
60	QY-1-13-DM-U2-60	9926251960	

Type: Single Pole (125 VDC)			
Current Ratings (amps)	Description	Part No.	
1	QY-1-13-DM-U2-01-B1	9926251801	
2	QY-1-13-DM-U2-02-B1	9926251802	
3	QY-1-13-DM-U2-03-B1	9926251803	
4	QY-1-13-DM-U2-04-B1	9926251804	
5	QY-1-13-DM-U2-05-B1	9926251805	
10	QY-1-13-DM-U2-10-B1	9926251810	
15	QY-1-13-DM-U2-15-B1	9926251815	
20	QY-1-13-DM-U2-20-B1	9926251820	
25	QY-1-13-DM-U2-25-B1	9926251825	
30	QY-1-13-DM-U2-30-B1	9926251830	
35	QY-1-13-DM-U2-35-B1	9926251835	
40	QY-1-13-DM-U2-40-B1	9926251840	
45	QY-1-13-DM-U2-45-B1	9926251845	
50	QY-1-13-DM-U2-50-B1	9926251850	
60	QY-1-13-DM-U2-60-B1	9926251860	

9926 Series Double Pole (80 VDC)



9926 Series Double Pole (125 VDC)



Type: Double Pole (80 VDC)			
Current Ratings (amps)	Description	Part No.	
5	QY-2-13-DM-U2-5A	9926252905	
10	QY-2-13-DM-U2-10A	9926252910	
15	QY-2-13-DM-U2-15A	9926252915	
16	QY-2-13-DM-U2-16A	9926252916	
20	QY-2-13-DM-U2-20A	9926252920	
40	QY-2-13-DM-U2-40A	9926252940	

Type: Double Pole (125 VDC)			
Current Ratings (amps)	Description	Part No.	
5	QY-2-13-DM-U2-5A-B1	9926252805	
10	QY-2-13-DM-U2-10A-B1	9926252810	
15	QY-2-13-DM-U2-15A-B1	9926252815	
20	QY-2-13-DM-U2-20A-B1	9926252820	
30	QY-2-13-DM-U2-30A-B1	9926252830	
32	QY-2-13-DM-U2-32A-B1	9926252832	
40	QY-2-13-DM-U2-40A-B1	9926252840	
50	QY-2-13-DM-U2-50A-B1	9926252850	
60	QY-2-13-DM-U2-60A-B1	9926252860	

Supplementary Circuit Protection



Compared to traditional fuse installation, the UL1077/CSA C22.2 No.235 compliant circuit breakers listed here assist with the complex task of selecting correct types and characteristics and offer a less bulky installation solution. Our range of miniature, molded-case circuit breakers, in combination with our accessories for factory or on-site installation, offer enhanced control and monitoring capabilities. Installation kits include all parts and instructions to make the on-site job easy.

We supply UL1077/CSA C22.2 No.235 compliant 1, 2 and 3-pole-type circuit breakers from 0.5 to 60 Ampere and with type C and D characteristics.

Attachments such as neutral switches, auxiliary contacts and shunt trips are also available for this system. All accessories for modern busbar installations are available in compliance with the relevant UL standards.



Supplementary Circuit Breakers

Circuit Breakers
Thermal Magnetic Type

Our range of UL1077/GSA C22.2 No.235 supplementary protectors can be used where additional protection is required in control circuits. Combined with the accessories it also offers enhanced monitoring and control capabilities.

Single Pole - D Curve

Single Pole - C Curve

Current Ratings (amps)	Description	Part No.	Description	Part No.
0.5	Suppl / 1P Cct Brkr / D Curve / 0.5A	SU1D05AC	Suppl / 1P Cct Brkr / C Curve / 0.5A	SU1C05AC
1	Suppl / 1P Cct Brkr / D Curve / 1A	SU1D1AC	Suppl / 1P Cct Brkr / C Curve / 1A	SU1C1AC
2	Suppl / 1P Cct Brkr / D Curve / 2A	SU1D2AC	Suppl / 1P Cct Brkr / C Curve / 2A	SU1C2AC
3	Suppl / 1P Cct Brkr / D Curve / 3A	SU1D3AC	Suppl / 1P Cct Brkr / C Curve / 3A	SU1C3AC
5	Suppl / 1P Cct Brkr / D Curve / 5A	SU1D5AC	Suppl / 1P Cct Brkr / C Curve / 5A	SU1C5AC
10	Suppl / 1P Cct Brkr / D Curve / 10A	SU1D10AC	Suppl / 1P Cct Brkr / C Curve / 10A	SU1C10AC
15	Suppl / 1P Cct Brkr / D Curve / 15A	SU1D15AC	Suppl / 1P Cct Brkr / C Curve / 15A	SU1C15AC
20	Suppl / 1P Cct Brkr / D Curve / 20A	SU1D20AC	Suppl / 1P Cct Brkr / C Curve / 20A	SU1C20AC
25	Suppl / 1P Cct Brkr / D Curve / 25A	SU1D25AC	Suppl / 1P Cct Brkr / C Curve / 25A	SU1C25AC
30	Suppl / 1P Cct Brkr / D Curve / 30A	SU1D30AC	Suppl / 1P Cct Brkr / C Curve / 30A	SU1C30AC
40	Suppl / 1P Cct Brkr / D Curve / 40A	SU1D40AC	Suppl / 1P Cct Brkr / C Curve / 40A	SU1C40AC
50	Suppl / 1P Cct Brkr / D Curve / 50A	SU1D50AC	Suppl / 1P Cct Brkr / C Curve / 50A	SU1C50AC
60	Suppl / 1P Cct Brkr / D Curve / 60A	SU1D60AC	Suppl / 1P Cct Brkr / C Curve / 60A	SU1C60AC



Double Pole - D Curve

Double Pole - C Curve

Current Ratings (amps)	Description	Part No.	Description	Part No.
0.5	Suppl / 2P Cct Brkr / D Curve / 0.5A	SU2D05AC	Suppl / 2P Cct Brkr / C Curve / 0.5A	SU2C05AC
1	Suppl / 2P Cct Brkr / D Curve / 1A	SU2D1AC	Suppl / 2P Cct Brkr / C Curve / 1A	SU2C1AC
2	Suppl / 2P Cct Brkr / D Curve / 2A	SU2D2AC	Suppl / 2P Cct Brkr / C Curve / 2A	SU2C2AC
5	Suppl / 2P Cct Brkr / D Curve / 5A	SU2D5AC	Suppl / 2P Cct Brkr / C Curve / 5A	SU2C5AC
10	Suppl / 2P Cct Brkr / D Curve / 10A	SU2D10AC	Suppl / 2P Cct Brkr / C Curve / 10A	SU2C10AC
15	Suppl / 2P Cct Brkr / D Curve / 15A	SU2D15AC	Suppl / 2P Cct Brkr / C Curve / 15A	SU2C15AC
20	Suppl / 2P Cct Brkr / D Curve / 20A	SU2D20AC	Suppl / 2P Cct Brkr / C Curve / 20A	SU2C20AC
25	Suppl / 2P Cct Brkr / D Curve / 25A	SU2D25AC	Suppl / 2P Cct Brkr / C Curve / 25A	SU2C25AC
30	Suppl / 2P Cct Brkr / D Curve / 30A	SU2D30AC	Suppl / 2P Cct Brkr / C Curve / 30A	SU2C30AC
40	Suppl / 2P Cct Brkr / D Curve / 40A	SU2D40AC	Suppl / 2P Cct Brkr / C Curve / 40A	SU2C40AC
50	Suppl / 2P Cct Brkr / D Curve / 50A	SU2D50AC	Suppl / 2P Cct Brkr / C Curve / 50A	SU2C50AC
60	Suppl / 2P Cct Brkr / D Curve / 60A	SU2D60AC	Suppl / 2P Cct Brkr / C Curve / 60A	SU2C60AC



Triple Pole - D Curve

Triple Pole - C Curve

Current Ratings (amps)	Description	Part No.	Description	Part No.
1	Suppl / 3P Cct Brkr / D Curve / 1A	SU3D1AC	Suppl / 3P Cct Brkr / C Curve / 1A	SU3C1AC
2	Suppl / 3P Cct Brkr / D Curve / 2A	SU3D2AC	Suppl / 3P Cct Brkr / C Curve / 2A	SU3C2AC
5	Suppl / 3P Cct Brkr / D Curve / 5A	SU3D5AC	Suppl / 3P Cct Brkr / C Curve / 5A	SU3C5AC
10	Suppl / 3P Cct Brkr / D Curve / 10A	SU3D10AC	Suppl / 3P Cct Brkr / C Curve / 10A	SU3C10AC
15	Suppl / 3P Cct Brkr / D Curve / 15A	SU3D15AC	Suppl / 3P Cct Brkr / C Curve / 15A	SU3C15AC
20	Suppl / 3P Cct Brkr / D Curve / 20A	SU3D20AC	Suppl / 3P Cct Brkr / C Curve / 20A	SU3C20AC
25	Suppl / 3P Cct Brkr / D Curve / 25A	SU3D25AC	Suppl / 3P Cct Brkr / C Curve / 25A	SU3C25AC
30	Suppl / 3P Cct Brkr / D Curve / 30A	SU3D30AC	Suppl / 3P Cct Brkr / C Curve / 30A	SU3C30AC
40	Suppl / 3P Cct Brkr / D Curve / 40A	SU3D40AC	Suppl / 3P Cct Brkr / C Curve / 40A	SU3C40AC
50	Suppl / 3P Cct Brkr / D Curve / 50A	SU3D50AC	Suppl / 3P Cct Brkr / C Curve / 50A	SU3C50AC
60	Suppl / 3P Cct Brkr / D Curve / 60A	SU3D60AC	Suppl / 3P Cct Brkr / C Curve / 60A	SU3C60AC



Note: Additional current ratings available. Contact your local Weidmüller representative.

Accessories for Supplementary Circuit Breakers



Auxiliary contact

Module	Type of Contact	Contacts	Weight g/ Each	Packing Unit	Part No.
½	1 auxiliary contact	1NO	35	10	SAU10
½	2 auxiliary contact	1NO + 1NC	40	10	SAU11

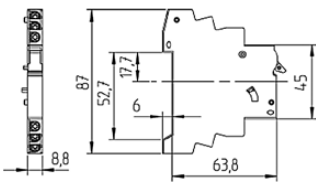

Standards Acc. to IEC 60947-5-1, DIN EN 60947-5-1, VDE 0660-200, UL508

Rated operating currents	10 A / 240 V AC 3 A / 110 V DC 1 A / 220 V DC
Minimum contact load	1 mA at 24 V DC
Conductor cross sections	
Type of conductor *)	min. max.
Single wire	1.0 mm ² (AWG18) 2.5 mm ² (AWG14)
Stranded wire	1.0 mm ² (AWG18) 1.5 mm ² (AWG16)
Stranded wire with ferrule	1.0 mm ² (AWG18) 1.5 mm ² (AWG16)
Torque	max. 0.8 Nm (7 lb.in)

*) Stripped length 8 - 9 mm



Shunt trip

Module	Rated Operating Voltage	Max. Operating Current at Un (t < 10 ms)	Weight g/ Each	Packing Unit	Part No.
1	24 V UC	0.6 A	105	5	SST24V
1	110 - 240 V UC, 415 V AC	0.25 A at 110 V 0.5 A at 240 V 0.58 A at 277 V	105	5	SST110V



Switching Devices Supplementary Protector

Rated Current i _n A	Rated Voltage Volt AC	Weight g/ Each	Packing Unit	Test Currents * Electromagnetic		Part No.
				Not Tripping I _e A	Tripping I _Δ A	
0.5 - 60	277/480	150	5	400	700	SNS63A

* additional electromagnetic protection



Lock-off/Lock-on device

Packing Unit	Weight g/ Each	Part No.
10	2	LD10

Accessories for Supplementary Circuit Breakers

Mounting Instructions of Accessories

Applies to SNS63A and SAU...:

The accessory devices SNS63A and SAU... can be installed on the right or left. The auxiliary contact H...UM can only be installed on the right.

Mounting:

1. Flick the blue switches of all devices to the "OFF" position
2. Remove the grey cover from the switching device and attachment
3. Insert the drive plate between the switching device and SNS63A and SAU...
4. Insert the connecting pin into the switch (insertion depth approx. 7 mm)
5. Combine switching device and SNS63A and SAU...
6. Screw devices together (observe correct screw length)

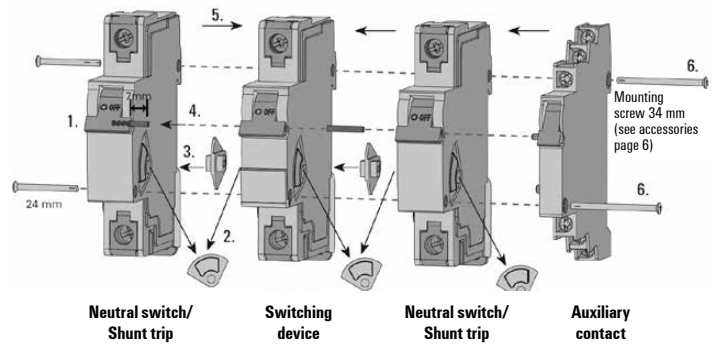

Applies to SAU...:

The auxiliary contact SAU... can only be installed on the right.

Installation:

1. Flick the blue switches of all devices to the "OFF" position
2. Remove the grey cover from the switching device
3. Combine switching device and SAU...
4. Insert connection screws and connect the two devices by turning the screws by 90°
5. After installation close and open to check operation

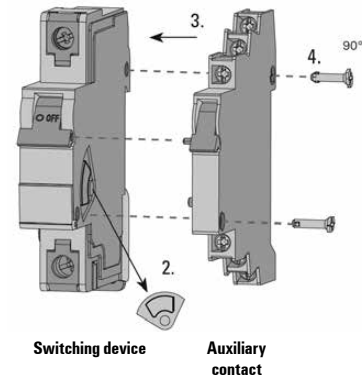

Applies to all switching devices

SAU..., SNS and SST...

Design of the terminals

- Optical detection of screw position
- Increased breaking resistance if the screwdriver becomes jammed
- Universal connecting terminals, suitable for connecting all known cable lugs such as ring or forked cable lugs and pin terminals
- Ring cable lugs can be connected by opening the flap and removing the connecting screw
- Can also be used for applications that require ring cable lugs (e.g. nuclear power stations)
- DIN EN 50274, VDE 0660-514 compliant protection against contact with live parts is fully guaranteed

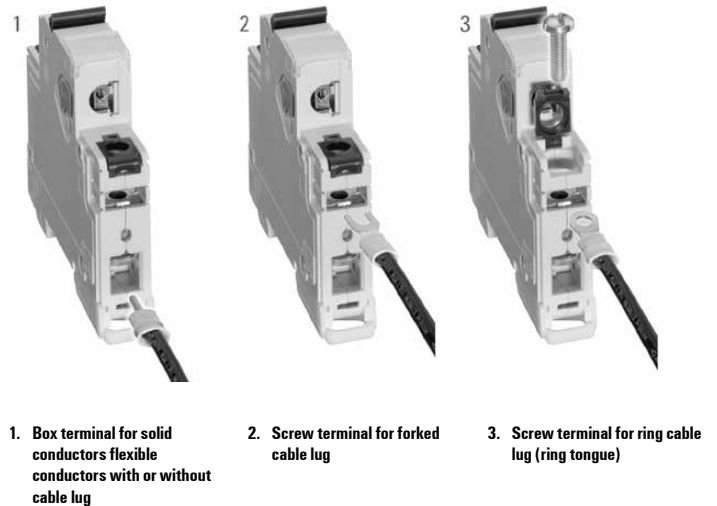

1. Box terminal for solid conductors flexible conductors with or without cable lug
2. Screw terminal for forked cable lug
3. Screw terminal for ring cable lug (ring tongue)

Busbar and Accessories for Supplementary Circuit Breakers (UL1077/CSA C22.2 No.235)

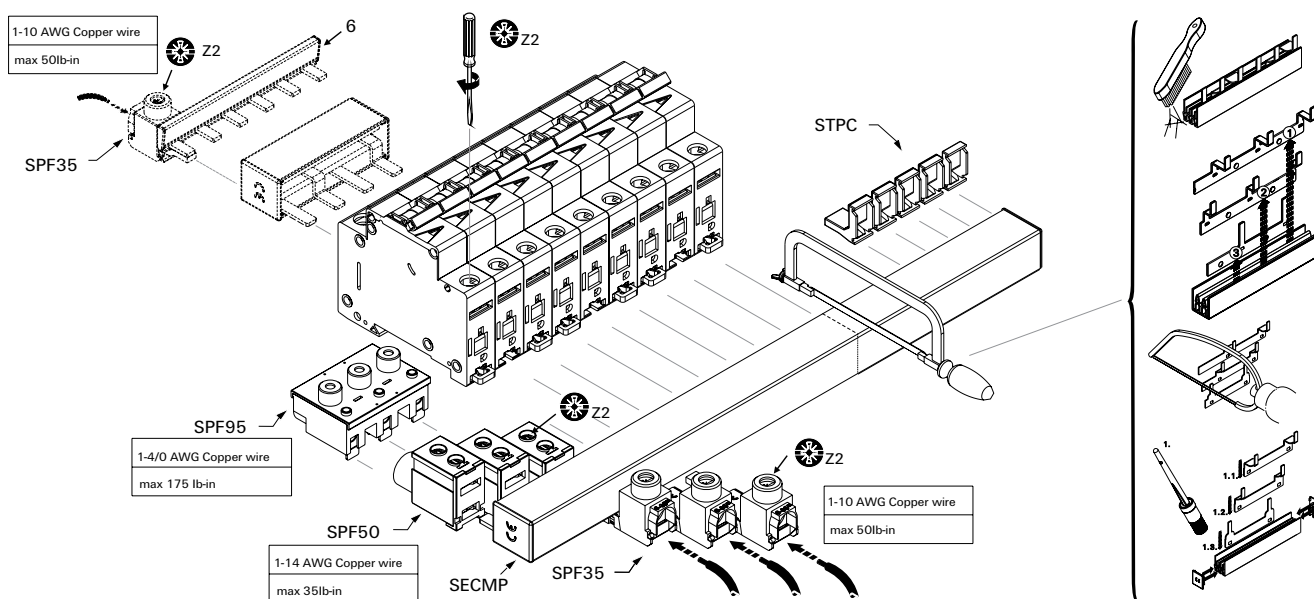

General Data

	SPF35
U_e	1000 V AC/DC
f	50/60 Hz
U_{imp}	-
I_b	115 A
	# 1-10 AWG 60°C Cu
	0.56 in
	All SB models
U_e	1P 600 V AC 1000V DC 2/3P 600V AC
f	50/60 Hz
U_{imp}	-
I_b	18mm ² / 25mm ²
Infeed at the start of the busbar	80A@40 °C / 100A@30°C
Infeed at the center of the busbar	160A@40°C / 200A@30°C

	SPF50
U_e	1000V AC/DC
f	50/60 Hz
U_{imp}	-
I_b	115 A
	# 1-14 AWG 75°C Cu
	0.56 in
	SPF95
U_e	600V AC/DC
f	50/60 Hz
U_{imp}	-
I_b	200 A
	# 1-4/0 AWG 75°C Cu
	1 in

Description	Part No.
Busbar/Supplementary Protection/1ph/6Poles	SB106
Busbar/Supplementary Protection/1ph/12Poles	SB112
Busbar/Supplementary Protection/Aux/1ph/37Poles	SB1A37
Busbar/Supplementary Protection/2ph/12Poles	SB212
Busbar/Supplementary Protection/2ph/18Poles	SB218
Busbar/Supplementary Protection/Aux/2ph/38Poles	SB2A38
Busbar/Supplementary Protection/3ph/12Poles	SB312
Busbar/Supplementary Protection/3ph/39Poles	SB339
Busbar/Supplementary Protection/Aux/3ph/48Poles	SB3A48P
PwrFeed Term - 35mm ²	SPF35
PwrFeed Term - 50mm ²	SPF50
PwrFeed Term - 95mm ²	SPF95
Touch Protection 5Caps	STPC
Endcap/1P busbars	SEC1P
Endcap/multi-P busbars	SECMP

Technical Data for Supplementary Circuit Breakers

Characteristic		C	D
Application		Lighting, Control circuits Wiring protection, Business equipment Appliances	Control transformers Power supplies Reactive load
Number of poles		1 - 3; 1 + N; 3 + N	
Standards		UL1077 and CSA-22.2 No.235	
Interrupting capacity		see data sheet for use in the USA and Canada	
Current limiting class		3	
Max. back-up fuse		see data sheet for use in the USA and Canada	
Rated voltage AC		277 / 480 V	
Rated current range		0.5 - 60 A	0.5 - 60 A
Test currents	Thermal not tripping $I_1 (A) > 1 \text{ h}$	$1.13 \times I_n$	$1.13 \times I_n$
	Thermal tripping $I_2 (A) < 1 \text{ ha}$	$1.45 \times I_n$	$1.45 \times I_n$
	Electromagnetic not tripping $I_4 (A) > 0,1 \text{ s}$	$5 \times I_n$	$10 \times I_n$
	Electromagnetic tripping $I_5 (A) < 0,1 \text{ s}$	$10 \times I_n$	$16 \times I_n$
Reference calibration temperature of the thermal tripping		$30^\circ \text{C} + 5^\circ \text{C}$ Influence of the ambient temperature on the thermal release: Decrease of the current values with higher ambient temperature and increase with lower temperatures of approximately 5% per 10°C difference in temperature	
Frequency range of the electromagnetic trip		$16^{2/3}$ to 60 Hz	
Ambient temperature		-25°C to $+55^\circ \text{C}$	
Storage temperature		-40°C to $+70^\circ \text{C}$	
Device depth according to DIN 43880		68 mm	
Mechanical live		10,000 cycles (ON / OFF)	
Protection cover		Finger safe and safe to back of hand according to DIN EN 50274/ VDE0660-514	
Insulation group acc. to DIN/VDE 0110		C at 250 V AC B at 400 V AC	
Degree of protection acc. to EN/IEC 60529		IP20	
Installation position		any	
Mounting		DIN-rail according to DIN EN 60715 35 mm	
Lockability		The handle can be secured against manual switching in the on and off position by a lead seal	
Climatic resistance		Humid heat constant according to DIN EN 60068-2-78 Humid heat cycle according to DIN EN 60068-2-30	
Vibration resistance		$> 15 \text{ g}$ according to DIN EN 60068-2-59 during a load with I_1	
Resistance to mechanical shocks		$25\text{g } 11\text{ms}$	
Approvals - SU... items		cRUus marking, UL file E359481, ref standards UL1077 and CSA-C22.2 No. 235	
Approvals - SAU..., SNS..., SST... items		UL marking, UL file E362205, ref standards UL1077 and CSA-C22.2 No. 14	
Approvals - SB..., SPF..., STPC..., SEC... items		pending	

Curves for Supplementary Circuit Breakers

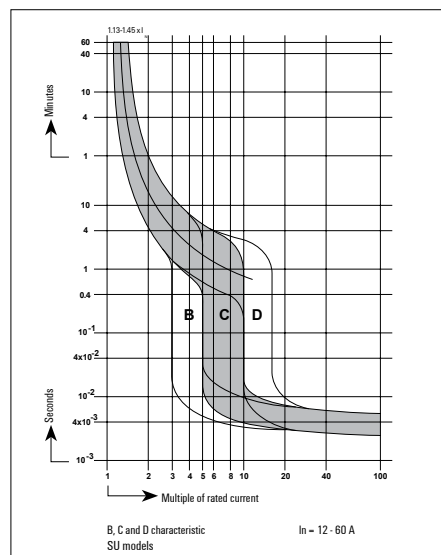
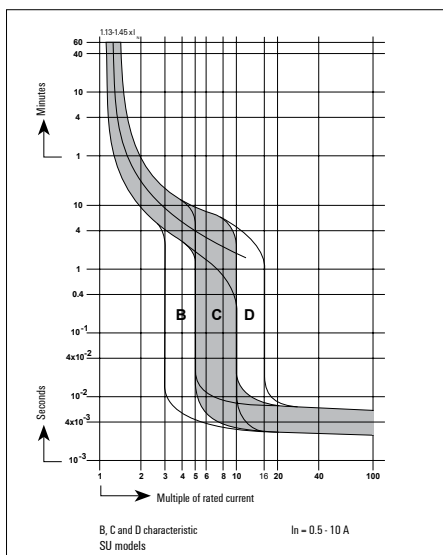

Technical Data for Supplementary Circuit Breakers

Conductor cross sections

Type of conductor *)	Box Terminal Bottom		Box Terminal Top	
	max.	min.	max.	min.
Single wire	35 mm ² (AWG2)	1 mm ² (AWG18)	25 mm ² (AWG3)	1 mm ² (AWG18)
Multiple wire	35 mm ² (AWG2)	16 mm ² (AWG6)	25 mm ² (AWG3)	16 mm ² (AWG6)
Stranded wire	25 mm ² (AWG3)	1 mm ² (AWG18)	16 mm ² (AWG6)	1 mm ² (AWG18)
Stranded wire with ferrule	16 mm ² (AWG6)	1 mm ² (AWG18)	16 mm ² (AWG6)	1 mm ² (AWG18)
Busbar cable lug	up to 3 mm thickness		up to 1.5 mm thickness	
Torque	max. 2.3 Nm (20 lb.in)			

*) Stripped length: bottom 12 - 14 mm, top 10 - 12 mm

Interrupting capacity and maximum back-up fuse for use in the USA and Canada

Characteristic	C and D				
Standards	UL1077 and CSA-22.2 No.235				
	Number of poles	Maximum rated voltage [V]	Rated current [A]	Interrupting capacity [kA]	Maximum back-up fuse [A]
Interrupting capacity at rated voltage Ambient temperature 40 °C	1 / 1 + N	277	0.5 - 10	10	70 A
	1 / 1 + N	277	12 - 60	10	4 x I _n
	2 / 3 / 3 + N	480	0.5 - 10	10	70 A
	2 / 3 / 3 + N	480	12 - 60	10	4 x I _n

Internal resistance for Product Range SU

Rated Current [A]	Trip Characteristic	
	C [Ohm]	D [Ohm]
0.5	6.8540	6.0009
1.0	1.7000	1.7560
2.0	0.4190	0.4190
3.0	0.2020	0.2020
4.0	0.1090	0.1090
5.0	0.0654	0.0654
6.0	0.0528	0.0491
8.0	0.0278	0.0240
10	0.0216	0.0187
12/13	0.0084	0.0085
15/16	0.0085	0.0076
20	0.0067	0.0064
25	0.0050	0.0041
30/32	0.0032	0.0027
40	0.0025	0.0022
50	0.0019	0.0018
60	0.0018	0.0017

Dimension Diagrams in mm (in.)

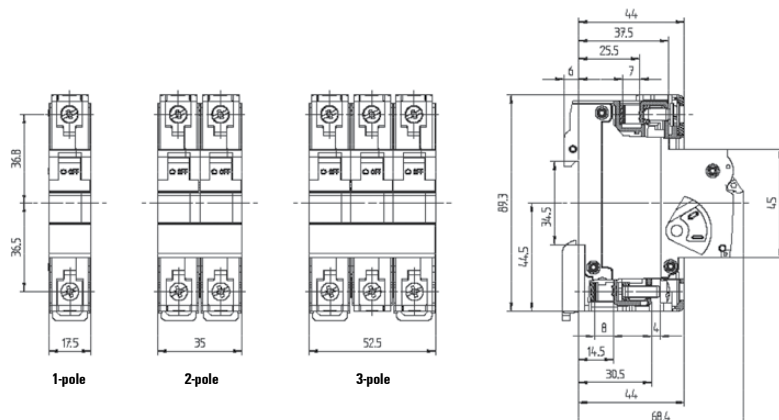

Circuit Breakers Hydraulic Magnetic Type

- AC Voltages 277/480V
- Trip curve 2 for general purpose applications
- UL 1077 recognized
- VDE approved and CE marked
- Just 13 mm wide
- Mounts to 35 mm DIN-rail
- Factory fitted auxiliary or trip alarm
- Single, double and triple pole versions

9926 Series Single Pole



9926 Series Double Pole



9926 Series Triple Pole



Ordering Data

Type: Single Pole (up to 277 VAC)

Type: Double Pole (up to 480 VAC)

Type: Triple Pole (up to 480 VAC)

Current Ratings (amps)	Description	Part No.
1	QZ-1-13-D-2-01	9926251501
2	QZ-1-13-D-2-02	9926251502
3	QZ-1-13-D-2-03	9926251503
4	QZ-1-13-D-2-04	9926251504
5	QZ-1-13-D-2-05	9926251505
6	QZ-1-13-D-2-06	9926251506
8	QZ-1-13-D-2-08	9926251508
10	QZ-1-13-D-2-10	9926251510
15	QZ-1-13-D-2-15	9926251515
20	QZ-1-13-D-2-20	9926251520
25	QZ-1-13-D-2-25	9926251525
35	QZ-1-13-D-2-35	9926251535
40	QZ-1-13-D-2-40	9926251540
50	QZ-1-13-D-2-50	9926251550
60	QZ-1-13-D-2-60	9926251560

Current Ratings (amps)	Description	Part No.
1	QZ-2-13-D-2-01	9926252501
2	QZ-2-13-D-2-02	9926252502
4	QZ-2-13-D-2-04	9926252504
5	QZ-2-13-D-2-05	9926252505
6	QZ-2-13-D-2-06	9926252506
10	QZ-2-13-D-2-10	9926252510
15	QZ-2-13-D-2-15	9926252515
20	QZ-2-13-D-2-20	9926252520
25	QZ-2-13-D-2-25	9926252525
30	QZ-2-13-D-2-30	9926252530
35	QZ-2-13-D-2-35	9926252535
40	QZ-2-13-D-2-40	9926252540
50	QZ-2-13-D-2-50	9926252550
60	QZ-2-13-D-2-60	9926252560

Current Ratings (amps)	Description	Part No.
10	QZ-3-13-D-2-10	9926253510
15	QZ-3-13-D-2-15	9926253515
20	QZ-3-13-D-2-20	9926253520
25	QZ-3-13-D-2-25	9926253525
30	QZ-3-13-D-2-30	9926253530
40	QZ-3-13-D-2-40	9926253540
50	QZ-3-13-D-2-50	9926253550
60	QZ-3-13-D-2-60	9926253560

Current Ratings (amps)	Description	Part No.
10	QZ-3-13-D-2-10	9926253510
15	QZ-3-13-D-2-15	9926253515
20	QZ-3-13-D-2-20	9926253520
25	QZ-3-13-D-2-25	9926253525
30	QZ-3-13-D-2-30	9926253530
40	QZ-3-13-D-2-40	9926253540
50	QZ-3-13-D-2-50	9926253550
60	QZ-3-13-D-2-60	9926253560

Accessories

Type	Part No.
Bus-bar (1 pole, insulated, 1 m)	67101904
Bus-bar (2 pole, insulated, 1 m)	67101972
Bus-bar (3 pole, insulated, 1 m)	67101971
Bus-bar end cap, 1 pole	67101973
Bus-bar end cap, 2 pole or 3 pole	67101974
Power lug, straight (14 mm)	67101960
Power lug, 90° (14 mm)	67101961
Power lug, straight (32 mm)	67102480
Power lug, 90° (32 mm)	67102479
Lock-out handle	67101913

Technical Data

Voltage	120/240 VAC, 50/60Hz
Current minimum	0.5A
Current maximum	60A
Interrupting capacity	5 kA @ 277/480 V, 5 kA @ 120 V, 5 kA @ 240 V
Dielectric strength	1500V, 50/60Hz
Insulation resistance	100 MΩ
Operating Life	10000 mechanical operations
Operating temperature	-40...+65°C
Wire size*	
1-15A:	14AWG min., 10AWG max.
20-25A:	10AWG min.
Torque	20 in.-lb

Approval

*UL 1077 Recognized, VDE (EN 60947-2) Approved, cURus (CSA C22.2 No. 235), CE Marked

Dimension Diagrams in mm (in.)

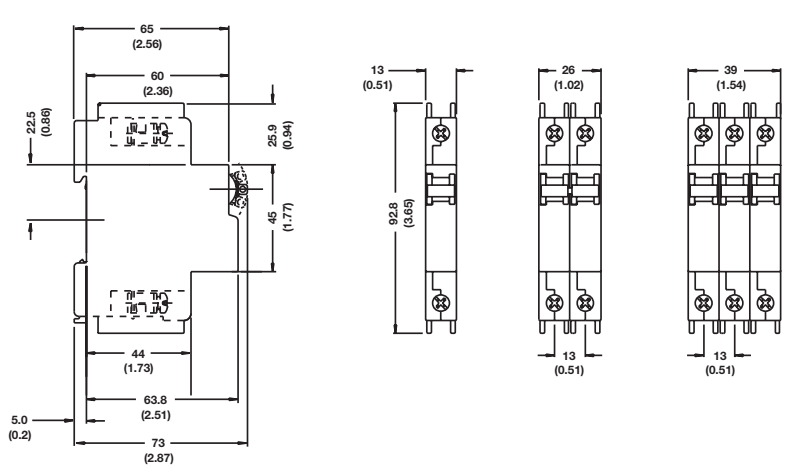

*Wire sizes: gauges specified are the minimum allowable as per CSA and UL standards.

The 9926 circuit breakers do not have provisions for marking tags. A possible solution is to cut the adhesive SchS2 tag rail to length (approximately 20 mm on a single pole unit so the current rating remains visible or approximately 30 mm on a two pole unit). The SchS2 accepts DEK, WS and ESG 8/17 marking tags. The part number for adhesive SchS2 is **1720600000**.

[†]cURus recognized to UL1077 and C22.2 No. 235

See Trip Curves 1, 3, 9, KM, OP - Page 26

9926 Series Supplementary Breakers with Contacts

Circuit Breakers
Auxiliary switch, Trip alarm,
Combination of both

- AC Voltages 277/480V
- Trip curve 2 for general purpose applications
- UL 1077 recognized
- VDE approved and CE marked
- Just 13 mm wide
- Mounts to 35 mm DIN-rail
- Factory fitted auxiliary or trip alarm
- Single, double and triple pole versions

Technical Data	
Voltage	120/240 VAC, 50/60Hz
Current minimum	0.5A
Current maximum	60A
Interrupting capacity	5 kA @ 277/480 V, 5 kA @ 120 V, 5 kA @ 240 V
Dielectric strength	1500 V, 50/60 Hz
Insulation resistance	100 MΩ
Operating Life	10000 mechanical operations
Operating temperature	-40...+65°C
Wire size*	
0.5-15A:	14AWG min., 10AWG max.
20-25A:	10AWG min.
Torque	20 in.-lb

Approval
†UL 1077 Recognized, VDE (EN 60947-2) Approved, cURus (CSA C22.2 No. 235), CE Marked

†UL 489 listed (5A, 250 VAC; 0.5A, 80 VDC Auxiliary; 0.5A, 125 VDC Trip Alarm)
 IEC 60947-5-1 Approved (5A, 250 VAC; 0.5A, 110 VDC Auxiliary; 0.5A, 125 VDC Trip Alarm)

*Wire sizes: gauges specified are the minimum allowable as per CSA and UL standards.

The 9926 circuit breakers do not have provisions for marking tags. A possible solution is to cut the adhesive SchS2 tag rail to length (approximately 20 mm on a single pole unit so the current rating remains visible or approximately 30 mm on a two pole unit). The SchS2 accepts DEK, WS and ESG 8/17 marking tags. The part number for adhesive SchS2 is 1720600000.

See Trip Curves 1, 2, 3, 9, OP - Page 26

9926 Series
Single Pole
w/ Auxiliary Contact[†]



Type: Single Pole Aux (up to 277 VAC)		
Current Ratings (amps)	Description	Part No.
1	QZ-A-1-13-D-2-01	9926261501
2	QZ-A-1-13-D-2-02	9926261502
5	QZ-A-1-13-D-2-05	9926261505
10	QZ-A-1-13-D-2-10	9926261510
15	QZ-A-1-13-D-2-15	9926261515
20	QZ-A-1-13-D-2-20	9926261520
25	QZ-A-1-13-D-2-25	9926261525

9926 Series
Double Pole
w/ Auxiliary Contact[†]



Type: Double Pole Aux (up to 480 VAC)		
Current Ratings (amps)	Description	Part No.
1	QZ-A-2-13-D-2-01	9926262501
2	QZ-A-2-13-D-2-02	9926262502
5	QZ-A-2-13-D-2-05	9926262505
10	QZ-A-2-13-D-2-10	9926262510
15	QZ-A-2-13-D-2-15	9926262515
20	QZ-A-2-13-D-2-20	9926262520
25	QZ-A-2-13-D-2-25	9926262525

9926 Series
Triple Pole
w/ Auxiliary Contact[†]



Type: Triple Pole Aux (up to 480 VAC)		
Current Ratings (amps)	Description	Part No.
1	QZ-A-3-13-D-2-01	9926263501
2	QZ-A-3-13-D-2-02	9926263502
5	QZ-A-3-13-D-2-05	9926263505
10	QZ-A-3-13-D-2-10	9926263510
15	QZ-A-3-13-D-2-15	9926263515
20	QZ-A-3-13-D-2-20	9926263520
25	QZ-A-3-13-D-2-25	9926263525

9926 Series
Single Pole Trip
(Alarm Contact)



Type: Single Pole Trip (up to 277 VAC)		
Current Ratings (amps)	Description	Part No.
1	QZ-T-1-13-D-2-01	9926271501
2	QZ-T-1-13-D-2-02	9926271502
5	QZ-T-1-13-D-2-05	9926271505
10	QZ-T-1-13-D-2-10	9926271510
15	QZ-T-1-13-D-2-15	9926271515
20	QZ-T-1-13-D-2-20	9926271520
25	QZ-T-1-13-D-2-25	9926271525

9926 Series
Double Pole Trip
(Alarm Contact)



Type: Double Pole Trip (up to 480 VAC)		
Current Ratings (amps)	Description	Part No.
1	QZ-T-2-13-D-2-01	9926272501
2	QZ-T-2-13-D-2-02	9926272502
5	QZ-T-2-13-D-2-05	9926272505
10	QZ-T-2-13-D-2-10	9926272510
15	QZ-T-2-13-D-2-15	9926272515
20	QZ-T-2-13-D-2-20	9926272520
25	QZ-T-2-13-D-2-25	9926272525

9926 Series
Triple Pole Trip
(Alarm Contact)



Type: Triple Pole Trip (up to 480 VAC)		
Current Ratings (amps)	Description	Part No.
1	QZ-T-3-13-D-2-01	9926273501
2	QZ-T-3-13-D-2-02	9926273502
5	QZ-T-3-13-D-2-05	9926273505
10	QZ-T-3-13-D-2-10	9926273510
15	QZ-T-3-13-D-2-15	9926273515
20	QZ-T-3-13-D-2-20	9926273520
25	QZ-T-3-13-D-2-25	9926273525

9926 Series
Single Pole Combination
(Auxiliary & Alarm Contact)[†]



Type: Single Pole Combo (up to 277 VAC)		
Current Ratings (amps)	Description	Part No.
1	QZ-AT-1-13-D-2-01	9926281501
2	QZ-AT-1-13-D-2-02	9926281502
5	QZ-AT-1-13-D-2-05	9926281505
10	QZ-AT-1-13-D-2-10	9926281510
15	QZ-AT-1-13-D-2-15	9926281515
20	QZ-AT-1-13-D-2-20	9926281520
25	QZ-AT-1-13-D-2-25	9926281525

9926 Series
Double Pole Combination
(Auxiliary & Alarm Contact)[†]



Type: Double Pole Combo (up to 480 VAC)		
Current Ratings (amps)	Description	Part No.
1	QZ-AT-2-13-D-2-01	9926282501
2	QZ-AT-2-13-D-2-02	9926282502
5	QZ-AT-2-13-D-2-05	9926282505
10	QZ-AT-2-13-D-2-10	9926282510
15	QZ-AT-2-13-D-2-15	9926282515
20	QZ-AT-2-13-D-2-20	9926282520
25	QZ-AT-2-13-D-2-25	9926282525

9926 Series
Triple Pole Combination
(Auxiliary & Alarm Contact)[†]



Type: Triple Pole Combo (up to 480 VAC)		
Current Ratings (amps)	Description	Part No.
1	QZ-AT-3-13-D-2-01	9926283501
2	QZ-AT-3-13-D-2-02	9926283502
5	QZ-AT-3-13-D-2-05	9926283505
10	QZ-AT-3-13-D-2-10	9926283510
15	QZ-AT-3-13-D-2-15	9926283515
20	QZ-AT-3-13-D-2-20	9926283520
25	QZ-AT-3-13-D-2-25	9926283525

Ground Fault Current Interrupt

- CE approved
- UL1077 and UL1053 recognized
- Small frame size (26mm wide)
- Single pole plus switched neutral ground leakage protection
- Trip point is unaffected by ambient temperature
- Current ratings up to 50A
- Trip indication (mid trip handle position)
- Trip curve 2 for general purpose applications

9926 Series GFCI



Ordering Data

Type: Triple Pole (up to 480 VAC)

9926 Series GFCI – dimensions in mm (in.)

Current Ratings (amps)	Description	Part No.
5	QF17A2505 - CB W/GFI	9926291105
10	QF17A2510 - CB W/GFI	9926291110
15	QF17A2515 - CB W/GFI	9926291115
20	QF17A2520 - CB W/GFI	9926291120
25	QF17A2525 - CB W/GFI	9926291125
30	QF17A2530 - CB W/GFI	9926291130
50	QF17A2550 - CB W/GFI	9926291150

Technical Data

Standard Ampere Ratings (A)	5 to 50A
Sensitivity (mA)	30 (CE) / 22 (UL)
Number of Poles	1 + N
Equipment Type	Ground Leakage/GFCI @ 120 V, 5 kA @ 240 V
Rated Voltage (V)	230 (CE) / 240 (UL)
Rated Interrupting/Withstand Capacity (kA)	5kA / -
Weight (kg)	0.26
Trip Curve (standard)	2
Operating Temperature	-40 to +65°C

Approval

UL 1077 and UL 1053, CE

See Trip Curve 2 - Page 30

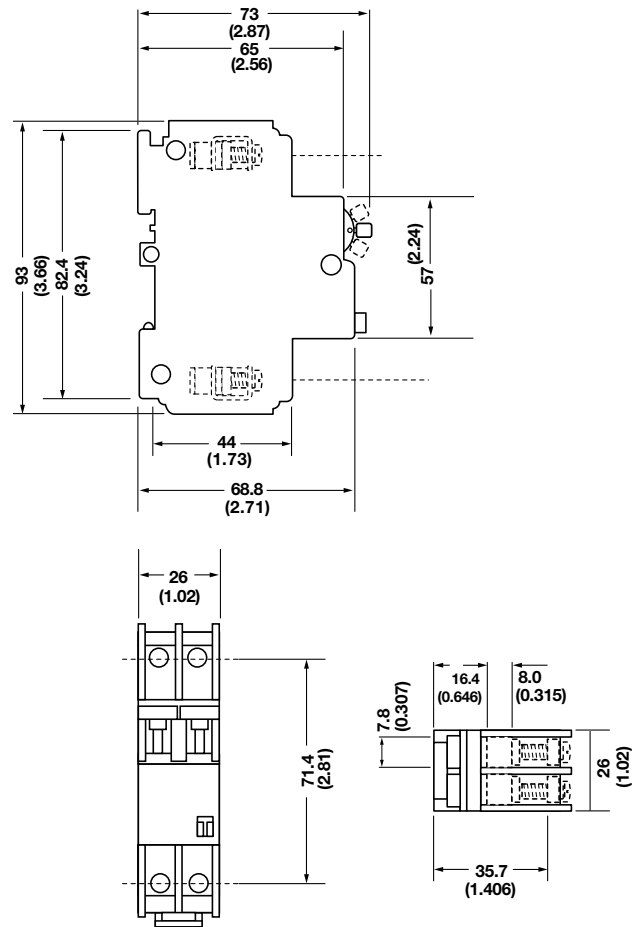

9926 Series Mounting Options and Accessories

Mounting Options

If the product is not vertically mounted in the normal DIN-rail mounting orientation, a rating factor must be applied. Figure 1 shows a diagram of the rating factor to apply. The published curves for these circuit breaker products are produced with the circuit breaker in the vertical mounting position. The rating factor only applies to the must hold and must trip points of the curve as the other parts (instantaneous trip point) stay largely unaffected.

It is important to note that in environments that are exposed to a high degree of vibration, the cables that connect to the circuit breaker must be securely held in place, as the breaker is not designed to carry the weight of the cables. A maximum of 35N can be applied to the terminal area, in a direction perpendicular to the mounting axis.

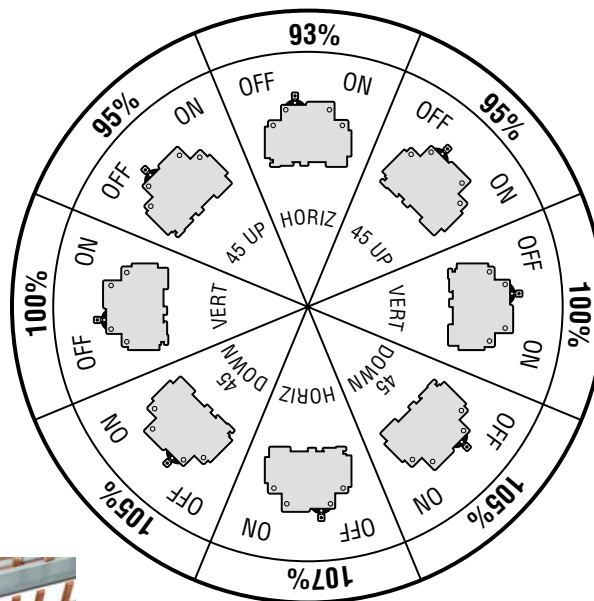

Accessories

Technical Data	
Current Rating	80A max.
Voltage	500V max.
Short Circuit Strength	25kA

Type	Part No.
Bus-bar (1 pole, insulated, 1 m)	67101904
Bus-bar (2 pole, insulated, 1 m)	67101972
Bus-bar (3 pole, insulated, 1 m)	67101971

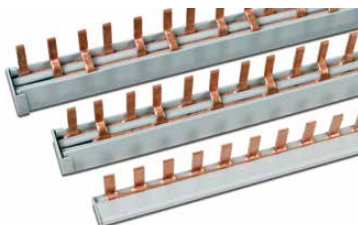

Part Number Table - Example

To order 9926 Series Single Pole Circuit Breaker
Part No. 9926251100

- Current Rating of 1.0 amp
- Internal Resistance per Pole of 1.1 ohms
- Trip Curve – M1, Medium (Standard)

9 9 2 6 2 5 1 0 0 0

Amperage

- *00* - 0.5A
- *01* - 1A
- *02* - 2A
- /
- *60* - 60A

Trip Curves (Types 5-9)

- *0* - Branch AC KM (Standard)
- *1* - Branch AC OP (Instantaneous)
- *2* - Branch AC 1 (Fast)
- *3* - Supplemental 9 (Slow)
- *4* - Branch 80VDC 1 (Fast)
- *5* - Supplemental 2 (Standard)
- *6* - Branch 125VDC OP (Instantaneous)
- *7* - Branch 80VDC OP (Instantaneous)
- *8* - Branch 125VDC U2 (Standard)
- *9* - Branch 80VDC U2 (Standard)

Poles

- 1 Pole
- 2 Pole
- 3 Pole

Type

- *5* - Base Breaker
- *6* - With Auxiliary Contact
- *7* - With Trip Alarm Contact
- *8* - Combo Aux/Trip Contact
- *9* - GFCI

Technical Data	
Current Rating	85A max.
Wire Size	10 AWG min., 4 AWG max.
Dimensions	A: 6 mm B: 32 mm

Type	Part No.
Bus bar end cap, 1 pole	67101973
Bus bar end cap, 2 pole or 3 pole	67101974



Type	Part No.
Power lug, straight (14 mm)	67101960
QF17A2505 - CB W/GFI	
Power lug, 90° (14 mm)	67101961
QF17A2510 - CB W/GFI	
Power lug, straight (32 mm)	67101980
QF17A2515 - CB W/GFI	



Type	Part No.
Lock-out handle	67101913
QF17A2505 - CB W/GFI	

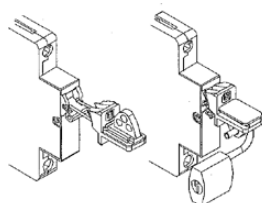

9 9 2 6 2 4 1 0 0 0

Amperage

- *00* - 0.5A
- *01* - 1A
- *02* - 2A
- /
- *60* - 60A

Trip Curves (Type 4)

- *0* - Supplemental 1 (Slow)
- *1* - Supplemental 3 (Fast)
- *3* - Branch AC 9 (Slow)

Poles

- 1 Pole
- 2 Pole
- 3 Pole

Type

- *4* - Base Breaker

9926 Series Trip Curves

Trip Curves—Hydraulic Magnetic Type
Typical time/current characteristics at 30°C

AC version

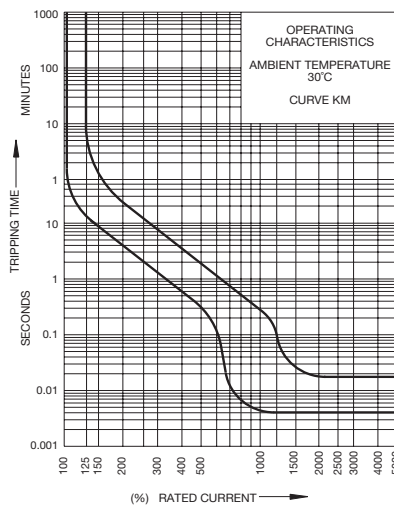
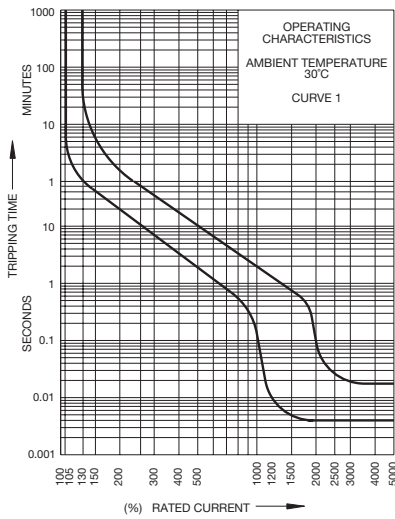

Trip Curve 1 applies to the following part numbers where "XX" is the current rating:
Single Pole— 99262512XX
Double Pole— 99262522XX

Sample trip characteristics - KM

	125%	150%	200%	400%	600%	800%	1000%
minimum (sec)	15	8	4	0.7	0.09	0.007	0.005
maximum (sec)	300	90	28	4	1.5	0.6	0.4

Although the 9926 series uses a magnetic only trip mechanism, CSA testing indicates a trip characteristic similar to thermal magnetic trip mechanisms. No de-rating is required at elevated temperatures.

Q-Frame Curve Equivalency Chart

CBI Curve	1	2	3	9	KM	U2	OP	Standard
Breaker Frame	QL	QL	QL	QL	QL		QL	UL489
	QY		QY		QY	QY	QY	UL489A
	QZ	QZ	QZ	QZ			QZ	UL1077
Equivalent Curve	D	C	B	K	C	C	Instantaneous	

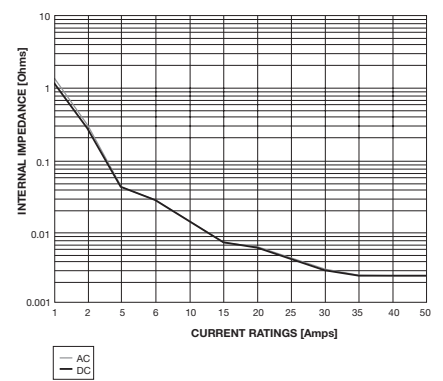
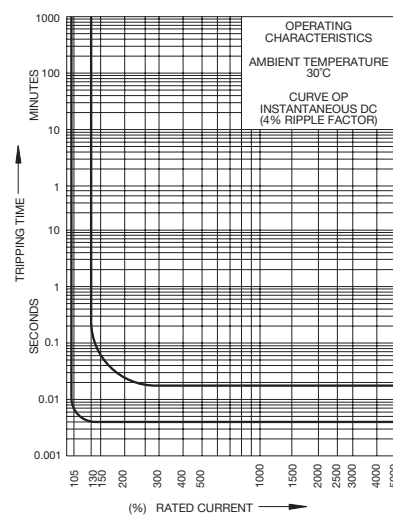
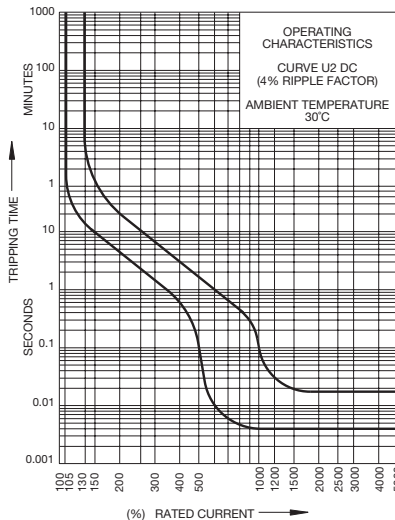
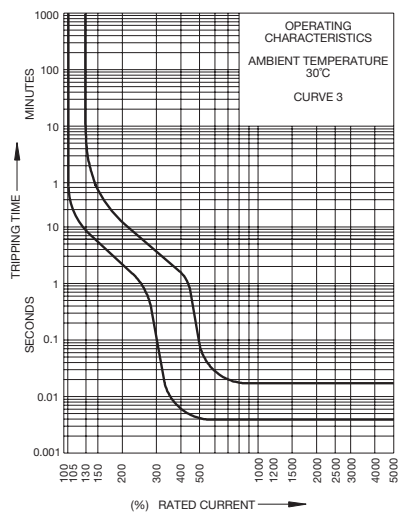
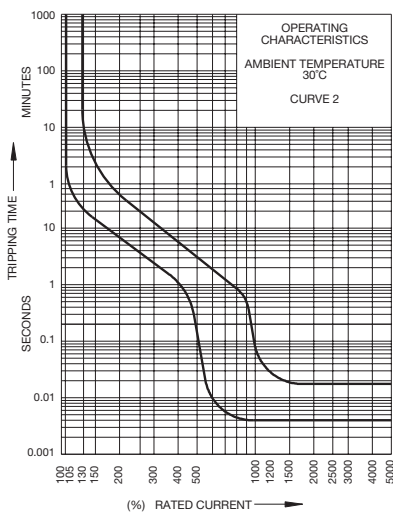
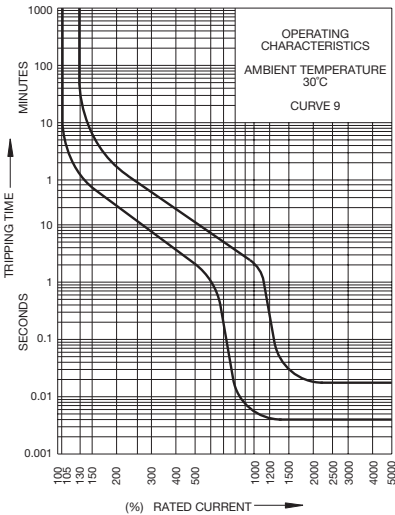

Additional trip curves and amp ratings are available upon request.

**CB4200 Series
Single Pole**

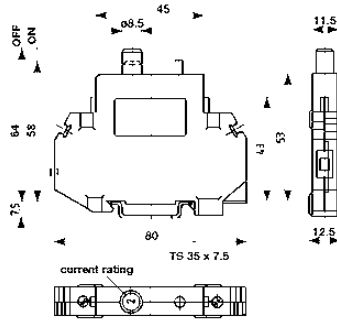

Internal Wiring Diagram

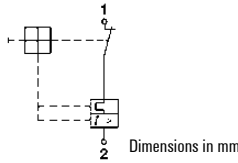

**CB4200 Series
Double Pole**

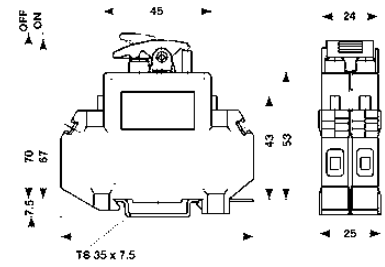

Internal Wiring Diagram

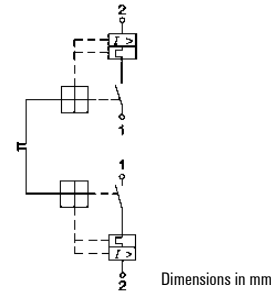

Technical Data

Rated voltage & current†	UL
	CSA
	VDE
Creepage resistance	
Dielectric strength	
Insulation resistance	
Interrupting capacity (VDE 0660, Part 101, P-2)	
Interrupting capacity; 4201 (UL 1077/EN 60934 PC1)	
Typical life at 2 x rated current	
Shock	
Torque	
Vibration	
Temperature range	
Corrosion	
Humidity	
Weight	
Wire size (UL)	

Technical Data

Voltage Ratings		
Current Ratings		
AC 250 V, DC 65 V, 50/60 Hz		0.05...16 A
AC 250 V, DC 65 V, 50/60 Hz		0.05...16 A
AC 250 V, DC 65 V, 50/60 Hz		0.05...16 A
PT1 600 to IEC 112		
4,000 VAC; IEC 664 & 664 A		
> 100 MM (DC 500 V)		
4201-10	Maximum capacity	
0.05...0.8 A	Self-limiting	
1...2 A	200 A	
2.5...16 A	400 A	
Rated current	Rated voltage	Maximum capacity
0.05...2.0 A	AC 250 V	200 A
2.0...16 A	AC 250 V	200 A
20 A	AC 125 V	400 A
5,000 operations		
25 g (11 ms) to IEC 68-2-27, Test Ea		
1.2 Nm		
5 g (57 to 500 Hz / ±0.38 mm, 10 to 57 Hz) to IEC 68-2-6, Test Fc		
-30°C...+55°C (-22°F...+131°F)		
96 hours at 5% salt spray, to IEC 68-2-11, Test Ka		
240 hours at 95% RH, to IEC 68-2-3, Test Ca		
60 g per pole		
#20...8 AWG	solid/0.5...6 mm ²	

Accessories

Jumpers	Daisy Chain 50*
	Straight CQB** insulated
	Angled CQB** insulated
Adapter foot (for TS 32 Rail)	
Busbar	Single pole 1 meter
Busbar end cap for 6720000227	
Power lug for 6720000227	

Accessories

Type	Part No.
BDC 50	9970290000
CQB 2	9970560000
CQB 3	9970570000
CQB 4	9970580000
CQB 10	9970590000
CQB 2	9970600000
CQB 3	9970610000
CQB 4	9970620000
CQB 10	9970630000
MCBAF/TS 32	9102100000
	6720000227
	6720000225
	6720000226

Marking Tags

Note: Part numbers are shown for a single card of pre-printed tags numbered 1-50.	Special print only
	Consecutive horizontal
	Consecutive vertical

Marking Tags

WS 8/5 MC	1640750000***
DEK 5/5	0473460001
DEK 5/5	0473560001

†Note: Resistive and inductive loads (0.05 - 16 A)
 *BDC will accommodate 20 A per pin, 20 A total
 **CQB will accommodate 18 A per pin, 18 A total; dedicated to 4201 Series
 ***Please specify horizontal or vertical print when ordering.
 Standard quantity = 144 tags per card.

Circuit Breakers Thermal Magnetic Type

- Rated from 0.1 to 32.0 amps
- Available in single, double and triple pole configurations
- Offers normally open (N/O) and normally closed (N/C) auxiliary contacts
- Lever-switch trip/reset function
- Mounts on 32mm or 35mm DIN-rail
- UL 1077 recognized
- CSA C22.2 No. 235

CB2211-10 Single Pole



CB2212-10 Double Pole



CB2213-10 Triple Pole



Ordering Data
Internal Resistance per Pole (ohms) (M1)
92
26.1
11.6
6.6
4.1
3
1.65
1.1
0.47
0.28
0.183
0.124
0.077
0.063
0.045
≤0.02
≤0.02
≤0.02
≤0.02
≤0.02
≤0.02
≤0.02
≤0.02
≤0.02
≤0.02

Type: Single Pole - CB2211-10			
Current Ratings (amps)	N/O Aux. Part No.	N/C Aux. Part No.	
0.1	9911010000	9911010005	
0.2	9911020000	9911020005	
0.3	9911030000	9911030005	
0.4	9911040000	9911040005	
0.5	9911050000	9911050005	
0.6	9911060000	9911060005	
0.8	9911080000	9911080005	
1.0	9911100000	9911100005	
1.5	9911150000	9911150005	
2.0	9911200000	9911200005	
2.5	9911250000	9911250005	
3.0	9911300000	9911300005	
4.0	9911400000	9911400005	
5.0	9911500000	9911500005	
6.0	9911600000	9911600005	
8.0	9911800000	9911800005	
10	9921100000	9921100005	
12	9921200000	9921200005	
15	9921500000	9921500005	
16	9921600000	9921600005	
18	9921800000	9921800005	
20	9921200000	9921200005	
25	9921250000	9921250005	
32	9921320000	9921320005	

Type: Double Pole - CBB2212-10			
Current Ratings (amps)	N/O Aux. Part No.	N/C Aux. Part No.	
0.1	9912010000	9912010003	
0.2	9912020000	9912020003	
0.3	9912030000	9912030003	
0.4	9912040000	9912040003	
0.5	9912050000	9912050003	
0.6	9912060000	9912060003	
0.8	9912070000	9912070003	
1.0	9912080000	9912080003	
1.5	9912100000	9912100003	
2.0	9912200000	9912200003	
2.5	9912250000	9912250003	
3.0	9912300000	9912300003	
4.0	9912400000	9912400003	
5.0	9912500000	9912500003	
6.0	9912600000	9912600003	
8.0	9912800000	9912800003	
10	9922100000	9922100003	
12	9922120000	9922120003	
15	9922150000	9922150003	
16	9922160000	9922160003	
18	9922180000	9922180003	
20	9922200000	9922200003	
25	9922250000		
32	9922320000		

Type: Triple Pole - CBB2213-10			
Current Ratings (amps)	N/O Aux. Part No.	N/C Aux. Part No.	
0.1	9913010000	9913010003	
0.2	9913020000	9913020003	
0.3	9913030000	9913030003	
0.4	9913040000	9913040003	
0.5	9913050000	9913050003	
0.6	9913060000	9913060003	
0.8	9913080000	9913080003	
1.0	9913100000	9913100003	
1.5	9913150000	9913150003	
2.0	9913200000	9913200003	
2.5	9913250000	9913250003	
3.0	9913300000	9913300003	
4.0	9913400000	9913400003	
5.0	9913500000	9913500003	
6.0	9913600000	9913600003	
8.0	9913800000	9913800003	
10	9923100000	9923100003	
12	9923120000	9923120003	
15	9923150000	9923150003	
16	9923160000	9923160003	
18	9923180000	9923180003	
20	9921320000	9921320003	
25	9923250000		
32	9923320000		

Part Number Table - Example

To order CB2212-10 Double Pole Circuit Breaker with N/O Aux., Part No. 9912100003

- Current Rating of 1.0 amps
- Internal Resistance per Pole of 1.1 ohms
- Trip Curve - M1, Medium (Standard)
- N/C - N/O Auxiliary Contacts

9 9 1 2 1 0 0 0 3

Auxiliary Contacts*

- *00* - N/C Auxiliary Contact
- *02* - W/O Auxiliary Contact
- *03* - N/C - N/O Auxiliary Contacts (double and triple pole only)
- *05* - N/O Auxiliary Contact

Trip Curves (Type 4)

- *00* - M1, Medium (standard)
- *11* - F1, Fast (DC only)
- *12* - M3, Low Resistance
- *13* - T1, Delayed

Base Part No. (Indicates number of poles)

Standard Current Ratings and Typical Internal Resistance Values
Internal Resistance (ohms)

Current Ratings (amps)	F1 fast acting for DC	M1 standard delay for AC & DC	T1 delayed for AC	M3 low resistance standard delay for AC & DC	T2 thermal for AC & DC
0.1	162	92	81	42	77
0.2	39.3	26.1	24.2	11.7	23
0.3	17.5	11.6	10.4	5.6	10.2
0.4	9.2	6.6	6.0	2.9	5.7
0.5	6.8	4.1	3.9	1.75	3.7
0.6	4.2	3	2.7	1.42	2.6
0.8	2.8	1.6	1.53	0.75	1.39
1.0	1.6	1.10	0.98	0.5	0.9
1.5	0.78	0.47	0.42	0.22	0.36
2.0	0.42	0.28	0.24	0.136	0.19
2.5	0.26	0.183	0.17	0.083	0.141
3.0	0.8	0.124	0.12	0.057	0.091
4.0	0.12	0.077	0.073	0.041	0.051
5.0	0.092	0.063	0.055	0.032	0.040
6.0	0.054	0.045	0.039	0.021	0.027
8.0	0.025	≤0.02	≤0.02	≤0.02	≤0.02
10	0.022	≤0.02	≤0.02	≤0.02	≤0.02
12	≤0.02	≤0.02	≤0.02	≤0.02	≤0.02
16	≤0.02	≤0.02	≤0.02	≤0.02	≤0.02
20	-	≤0.02	≤0.02	-	≤0.02
25	-	≤0.02	≤0.02	-	≤0.02
32	-	≤0.02	≤0.02	-	≤0.02

*Auxiliary for the 2-pole will be configured: N/C for 1st pole & N/O for 2nd pole. Auxiliary for the 3-pole will be configured: N/C for 1st pole & N/O for the 3rd pole.

*Standard breakers will be calibrated to a M1 trip curve with N/O Auxiliary Contacts.

CB2200 Series

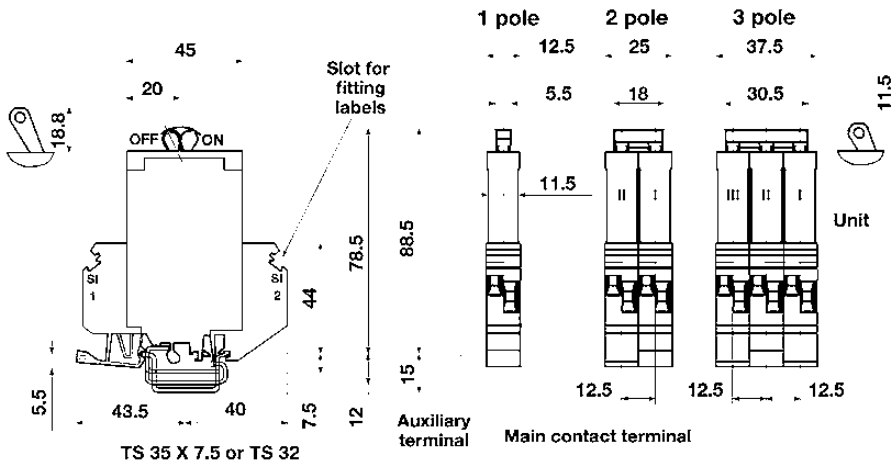

Dimensions in mm

Technical Data	
Rated voltage & current†	UL
	CSA
	VDE
Auxiliary contacts	
Creepage resistance	
Dielectric strength	
Insulation resistance	
Interrupting capacity (VDE 0660, Part 101, P-2)	
Interrupting capacity (UL 1077/EN 60934 PC1)	
Typical life at 2 x rated current	
Shock	
Torque Nm (lb. in.)	
Vibration	
Temperature range	
Corrosion	
Humidity	
Weight	
Wire size (UL)	
Accessories	
Jumpers	Daisy Chain 50
Busbars	
Marking Tags	
1 2 3 4 5 6	Special print only
	Consecutive horizontal
	Consecutive vertical

Note: Part numbers shown are for a single card of pre-printed tags numbered 1-50.

†Note: Resistive and inductive loads (0.05 - 16 A)

*Please specify horizontal or vertical print when ordering.

Voltage Ratings		Current Ratings	
277 / 480 VAC (50/60 Hz); 65 VDC		0.1...32 A	
277 / 480 VAC (50/60 Hz); 65 VDC		0.1...32 A	
250 / 415 VAC / 65 VDC		0.1...32 A	
250 VAC / 65 VDC, 1 A			
PTI 600 to IEC 112			
3,000 VAC; IEC 664 & 664 A			
> 100 MΩ (DC 500 V)			
Rated current	Rated voltage	Rupture capacity (3 times)	
0.05...0.8 A	250 / 415 VAC	400 A	
6...32 A	250 / 415 VAC	800 A	
Rated current	Rated voltage	Max. rupture capacity (3 times)	
0.1...16 A	277 / 480 VAC	5000 A	
20...32 A	277 / 480 VAC	2000 A	
0.1...32 A	65 VDC	2000 A	
5,000 operations			
25 g (11 ms) to IEC 68-2-27, Test Ea			
0.6 (5.3) Auxiliary contact: 0.5 (4.4)			
5 g (57 to 500 Hz / ±0.38 mm, 10 to 57 Hz) to IEC 68-2-6, Test Fc			
-30...+60°C (-22°F...+140°F)			
96 hours at 5% salt spray, to IEC 68-2-11, Test Ka			
240 hours at 95% RH, to IEC 68-2-3, Test Ca			
Approximately 60 g per pole			
max 6 mm²...8 AWG		max 1.5 mm²...14 AWG (Aux. contact)	
Type	Part No.		
BDC 50, 20 A maximum	9970290000		
1 pole (CB2200)	9986510000		
2 pole (CB2200)	9987360000		
Type	Part No.		
DEK 5/6	0490360000*		
DEK 5/6	0468660001		
DEK 5/6	0468760001		

Trip Curves—Thermal Magnetic Type
Typical time/current characteristics at 23°C

CB2200 Series

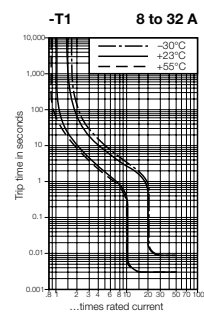
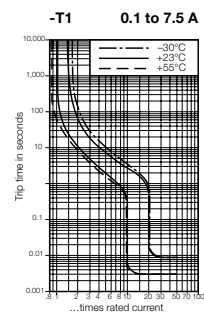
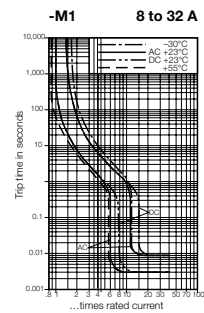
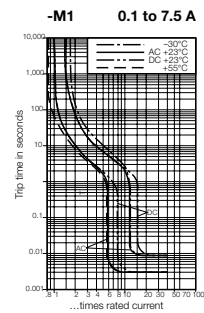
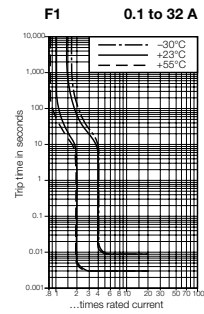

CB9100 Series

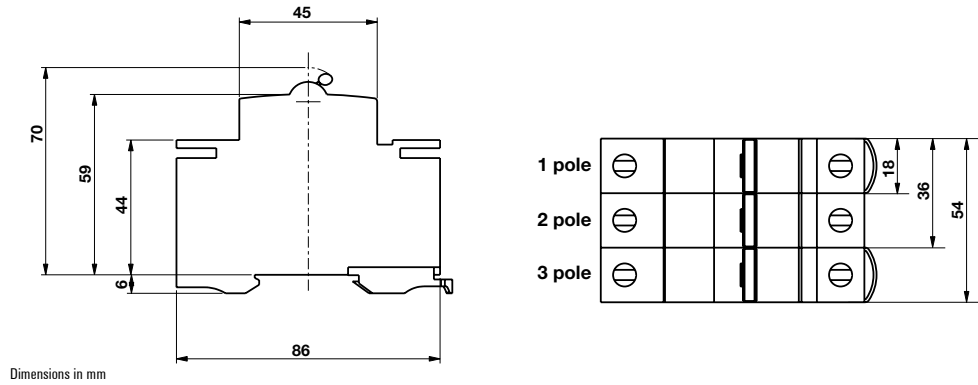

Dimensions in mm

Internal Wiring Diagram

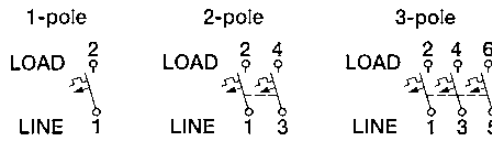

Technical Data

Rated voltage & current	UL 1077 CSA C 22.2 No. 235 VDE															
Creepage resistance	PTI 250 to IEC 112															
Insulation resistance	>100 MΩ at 500 VDC															
Interrupting capacity (UL 1077/EN 609334 PC1) 1 pole	<table border="1"> <thead> <tr> <th>Current ratings</th> <th>Interrupting Rupture capacity (3X)</th> <th>Voltage</th> </tr> </thead> <tbody> <tr> <td>0.5...63 A</td> <td>10,000 A (UL)</td> <td>277 VAC/50 VDC</td> </tr> <tr> <td>0.5...32 A</td> <td>2,000 A (UL)</td> <td>277 / 480 AC</td> </tr> <tr> <td>0.5...63 A</td> <td>6,000 A (UL)</td> <td>50 VDC (1) pole</td> </tr> <tr> <td>0.5...50 A</td> <td>6,000 A (UL)</td> <td>110 VDC (2) poles</td> </tr> </tbody> </table>	Current ratings	Interrupting Rupture capacity (3X)	Voltage	0.5...63 A	10,000 A (UL)	277 VAC/50 VDC	0.5...32 A	2,000 A (UL)	277 / 480 AC	0.5...63 A	6,000 A (UL)	50 VDC (1) pole	0.5...50 A	6,000 A (UL)	110 VDC (2) poles
Current ratings	Interrupting Rupture capacity (3X)	Voltage														
0.5...63 A	10,000 A (UL)	277 VAC/50 VDC														
0.5...32 A	2,000 A (UL)	277 / 480 AC														
0.5...63 A	6,000 A (UL)	50 VDC (1) pole														
0.5...50 A	6,000 A (UL)	110 VDC (2) poles														
Mechanical/Electrical endurance	20,000/10,000															
Shock	20 g (10 ms)															
Torque	2 Nm															
Vibration	3 g (10 to 55 Hz)															
Temperature range - operating	-25°C...+55°C (-13°F to 131°F)															
Weight	1 pole (130 g); 2 pole (280 g); 3 pole (430 g)															
Strip length	12 mm															
Auxiliary contact rating	<table border="1"> <thead> <tr> <th>Voltage</th> <th>Current</th> </tr> </thead> <tbody> <tr> <td>AC 220/240</td> <td>5 A</td> </tr> <tr> <td>AC 277</td> <td>3 A</td> </tr> <tr> <td>DC 24 V</td> <td>4 A</td> </tr> <tr> <td>DC 60 V</td> <td>1 A</td> </tr> <tr> <td>DC220 V</td> <td>0.4 A</td> </tr> </tbody> </table>	Voltage	Current	AC 220/240	5 A	AC 277	3 A	DC 24 V	4 A	DC 60 V	1 A	DC220 V	0.4 A			
Voltage	Current															
AC 220/240	5 A															
AC 277	3 A															
DC 24 V	4 A															
DC 60 V	1 A															
DC220 V	0.4 A															
Wire size	#18...2 AWG (line); #18...3 AWG (load)															

Auxiliary Contact Modules

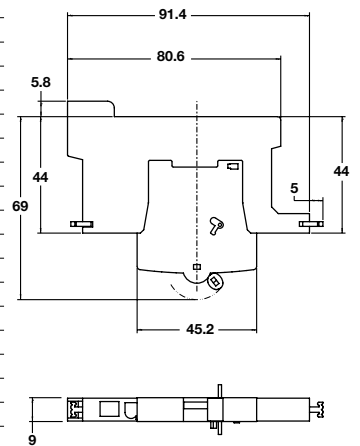

Accessories

Jumpers	
Auxiliary contacts	SPDT
Security hardware	

Type	Current Side/Middle	Part No.
3 pole bus, 10 x 1010 mm, buses (19) 3 phase groupings	80A/100A	9970330000
3 pole bus, 16 x 210 mm, buses (4) 3 phase groupings	120A/130A	9970340000
3 pole bus, 16 x 1010 mm, buses (19) 3 phase groupings	120A/130A	9970350000
1 pole bus, 12 x 210 mm, buses 12 breakers	80A/100A	9970360000
1 pole bus, 12 x 210 mm (insulated), buses 12 breakers	63A	9991990000
Bus bar clamp	130A	9970370000
Auxiliary contacts		9970300000
Lock out cover		9970380000

Internal Auxiliary Wiring Diagram

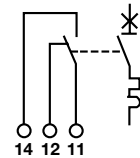

Marking Tags

Adhesive label	
----------------	--

ETO 10/26, yellow (26 mm x 10 mm)	1686401687
-----------------------------------	------------

Electronic Circuit Protection

ESX10-T



Electronic circuit protection type ESX10-T is designed to ensure selective disconnection of 24VDC load systems.

24VDC power supplies, which are widely used in industry today, will shut down the output in the event of an overload with the result that one faulty load in the system can lead to complete disconnection of all loads.

Through selective disconnection the ESX10-T responds much faster to overload or short circuit conditions than the switch-mode power supply. This is achieved by active current limitation. The ESX10-T limits the highest possible current to 1.3 to 1.8 times the selected rated current of the circuit protector. Thus it is possible to switch on capacitive loads of up to 20,000 μF , but they are disconnected only in the event of an overload or short circuit.

For optimal alignment with the characteristics of the application the current rating of the ESX10-T can be selected in fixed values from 0.5 A... 12 A. Failure and status indication are provided by a multicolor LED and an integral short-circuit-proof status output or a relay signal contact. Remote operation is possible by means of a remote reset signal or a remote ON/OFF control signal. The manual ON/OFF button allows separate actuation and reset of individual load circuits.

Upon detection of overload or short circuit in the load circuit, the MOSFET of the load output will be blocked to interrupt the current flow. The load circuit can be re-activated via the remote electronic reset input, control input or manually by means of the ON/OFF button.

Features

- Selective load protection, electronic trip characteristics
- Active current limitation for safe connection of capacitive loads up to 20,000 μF and on overload/short circuit
- Current ratings 0.5 A... 12 A
- Reliable overload disconnection with $1.1 \times I_N$ plus, even with long load lines or small cable cross sections (see table 4)
- Manual ON/OFF button (S1)
- Control input IN+ for remote ON/OFF signal (option)
- Electronic **reset** input RE (option)
- Clear status and failure indication through LED, status output SF or Si contact F
- Integral fail-safe element adjusted to current rating
- Width per unit only 12.5 mm
- Rail mounting
- Ease of wiring through busbar LINE+ and 0 V as well as signal bars and bridges
- Hazardous area approved– Class 1 Div 2, Zone 2m ATEX Zone Z

Approvals

Authority	Voltage rating	Current ratings
UL2367 (E306740)	24VDC	0.5...12 A
UL1604 (E322549) (class 1, div. 2, group A, B, C, D)	24VDC	0.5...12 A
UL508/ cUL 508	24VDC	0.5...12 A
CSA file 165971: CSA C22.2 No: 213 (class 1, div. 2) Groups A, B, C, D, T5	24VDC	0.5...12 A
CSA C22.2 No: 142	24VDC	0.5...12 A

Class 2
Meets requirements for Class 2 current limitation
(ESX10-T... 0.5 A / 1 A / 2 A / 3 A)

Technical Data (T_{ambient} = 40°C, operating voltage U_b = 24VDC)

Operating data	
Operating voltage U _b	24VDC (18...32 V)
Current rating I _n	fixed current ratings: 0.5, 1 A, 2 A, 3 A, 4 A, 6 A, 8 A, 10 A, 12 A
Closed current I _q	ON condition: typically 20...30 mA depending on signal output
Status indication by means of	<ul style="list-style-type: none"> multicolor LED: <p>GREEN: - unit is ON, power-MOSFET is switched on - status output SF ON, supplies + 24VDC</p> <p>ORANGE: in the event of overload or short circuit until electronic disconnection</p> <p>RED: - unit electronically disconnected - load circuit/Power-MOSFET OFF</p> <p>OFF: - manually switched off (S1 = OFF) or device is dead - undervoltage (U_b < 8 V) - after switch-on till the end of the delay period</p> <ul style="list-style-type: none"> status output SF (option) potential-free signal contact F (option) ON/OFF/ condition of switch S1

Load circuit

Load output	Power-MOSFET switching output (high side switch)
Overload disconnection	typically 1.1 x I _n (1.05...1.35 x I _n)
Short-circuit current I _K	active current limitation (see table 1)
Trip time for electronic disconnection	see time/current characteristics typically 3 s at I _{Load} > 1.1 x I _n typically 3 s...100 ms at I _{Load} > 1.8 x I _n (or 1.5 x I _n /1.3 x I _n)
Temperature disconnection	internal temperature monitoring with electronic disconnection
Low voltage monitoring load output	with hysteresis, no reset required load "OFF" at U _b < 8 V
Starting delay t _{start}	typically 0.5 sec after every switch-on and after applying U _b
Disconnection of load circuit	electronic disconnection
Free-wheeling circuit	external free-wheeling diode recommended with inductive load

Several load outputs must not be connected in parallel

Technical Data (T_{ambient} = 40°C, operating voltage U_b = 24VDC)

Status output SF ESX10-TB-114/-124/	
Electrical data	plus-switching signal output, nominal data: 24VDC / max. 0.2 A (short circuit proof) status output is internally connected to GND with a 10 kOhm resistor
Status OUT	ESX10-TB-114/-124 (signal status OUT), at U _b = +24 V +24 V = S1 is ON, load output connected through 0V = S1 is ON, load output blocked and/or switch S1 is OFF ESX10-TB127 reverse red LED lit
OFF condition	0 V level at status output when: <ul style="list-style-type: none"> switch S1 is in ON position, but device is still in switch-on delay switch S1 is OFF, or control signal OFF, device is switched off no operating voltage U_b
Signal output F ESX10-TB-101/-102	
Electrical data	potential-free signal contact max. 30VDC/0.5 A, min. 10 V/10 mA
ON condition LED green	voltage U _b applied, switch S1 is in ON position no overload, no short circuit
OFF condition LED off	<ul style="list-style-type: none"> device switched off (switch S1 is in OFF position) no voltage U_b applied
Fault condition LED orange	overload condition > 1.1 x I _n up to electronic disconnection
Fault condition LED red	electronic disconnection upon overload or short circuit device switched off with control signal (switch S1 is in ON position)
ESX10-TB-101	single signal, make contact contact SC/SO-SI open
ESX10-TB-102	single signal, break contact contact SC/SO-SI closed
Fault	signal output fault conditions: <ul style="list-style-type: none"> no operating voltage U_b ON/OFF switch S1 is in OFF position red LED lighted (electronic disconnection)
Reset input RE ESX10-TB-124	
Electrical data	voltage: max. +32VDC high > 8VDC ≤ 32VDC low ≤ 3VDC > 0 V power consumption typically 2.6 mA (+24VDC) min. pulse duration typically 10 ms
Reset signal RE (terminal 22)	The electronically blocked ESX10-TB-124 may remotely be reset via an external momentary switch due to the falling edge of a +24 V pulse. A common reset signal can be applied to several devices simultaneously. Switched on devices remain unaffected.
Control input IN+ ESX10-TB-114	
Control signal IN+ (terminal 21)	see reset input RE +24V level (HIGH): device will be switched on by a remote ON/OFF signal 0 V level (LOW): device will be switched off by a remote ON/OFF signal
Switch S1 ON/OFF	unit can only be switched on with S1 if a HIGH level is applied to IN+

Technical Data (T_{ambient} = 40°C, operating voltage U_b = 24VDC)

General data	
Fail-safe element:	backup fuse for ESX10-T not required because of the integral redundant fail-safe element
Terminals	LINE+ / LOAD+ / OV
screw terminals	M4
max. cable cross section	
flexible with wire end ferrule w/wo plastic sleeve	20-6 AWG (0.5 - 10 mm ²)
multi-lead connection (2 identical cables)	
rigid/flexible	20-11 AWG (0.5 - 4 mm ²)
flexible with wire end ferrule without plastic sleeve	20-13 AWG (0.5 - 2.5 mm ²)
flexible with TWIN wire end ferrule with plastic sleeve	20-9 AWG (0.5 - 6 mm ²)
wire stripping length	10 mm
tightening torque (EN 60934)	1.2 Nm
Terminals	aux. contacts
screw terminals	M3
max. cable cross section	
flexible with wire end ferrule w/wo plastic sleeve	23-13 AWG (0.25 - 2.5 mm ²)
wire stripping length	8 mm
tightening torque (EN 60934)	0.5 Nm
Housing material	moulded

Mounting	symmetrical rail to EN 50022-35x7.5
Ambient temperature	0...+50 °C (without condensation, see EN 60204-1)
Storage temperature	-20...+70 °C
Humidity	96 hrs/95 % RH/40 °C to IEC 60068-2-78-Cab climate class 3K3 to EN 60721
Vibration	3 g, test to IEC 68-2-6 test Fc
Degree of protection	housing: IP20 DIN 40050 terminals: IP20 DIN 40050
EMC (EMC directive, CE logo)	emission: EN 61000-6-3 susceptibility: EN 61000-6-2
Insulation co-ordination (IEC 60934)	0.5 kV/2 pollution degree 2 re-inforced insulation in operating area
dielectric strength	max. 32VDC (load circuit)
Insulation resistance (OFF condition)	n/a, only electronic disconnection
Approvals	UL2367, File E306740, Solid State Overcurrent Protectors UL1604 (class 1, div. 2, zone 2), UL508, CE logo CSA C22.2 No. 142 - file 165971, C22.2 No. 213 - file 165971, C1D2 Groups A, B, C, D, Temp Code T5; Ambient 0°-40°C
Dimensions (W x H x D)	12.5 x 80 x 83 mm
Mass	approx. 65 g

Table 1: Voltage drop, current limitation, max. load current

current rating I _n	typically voltage drop U _{on} at	active current limitation (typically)	max. load current at 100% ON duty	
			T _u = 40 °C	T _u = 50 °C
0.5 A	70 mV	1.8 x I _n	0.5 A	0.5 A
1 A	80 mV	1.8 x I _n	1 A	1 A
2 A	130 mV	1.8 x I _n	2 A	2 A
3 A	80 mV	1.8 x I _n	3 A	3 A
4 A	100 mV	1.8 x I _n	4 A	4 A
6 A	130 mV	1.8 x I _n	6 A	5 A
8 A	120 mV	1.5 x I _n	8 A	7 A
10 A	150 mV	1.5 x I _n	10 A	9 A
12 A	180 mV	1.3 x I _n	12 A	10.8 A

Attention: when mounted side-by-side without convection the ESX10-T should not carry more than 80% of its rated load with 100% ON duty due to thermal effects.

Please note:

- The user should ensure that the cable cross sections of the relevant load circuit are suitable for the current rating of the ESX10-T used.
- Automatic start-up of machinery after shut down must be prevented (Machinery Directive 98/37/EG and EN 60204-1). In the event of a short circuit or overload the load circuit will be disconnected electronically by the ESX10-T.
- Refer to UL/CSA file for proper wiring and installation techniques.

Table 2: Specifications

Protection	to EN6052 housing IP30, terminals IP00
CE logo	to 2004/108/EG and 94/9/EG
UL	UL2367, File No E306740 UL508, File No E322549 UL 1604, File No E320024
CSA	CSA C22.2 No 14, File No 165971 (LR16186) CSA C22.2 No 142, File No 165971 (LR16186) CSA C22.2 No 213, File No 165971 (LR16186)
ATEX	IEC/EN60079-0 /14/-15 Ⓢ II 3G Ex nA II B T4 Gc X

Table 3: ESX10-T - Ordering Information

Version	Signal input			Signal output					
	without Signal Input	Control input ON/OFF Reset	Remote Reset	without Signal Output	single signal N/O (normally open NO)	single signal N/C (normally closed NC)	without Signal Output	Status OUT Positive 24V = OK	Status OUT ØV = OK
ESX10-TA-100	x			x			x		
ESX10-TB-101	x				x		x		
ESX10-TB-102	x					x	x		
ESX10-TB-114		x						x	
ESX10-TB-124			x	x				x	
ESX10-TB-127			x	x					x

ESX10-TA-100		ESX10-TB-101		ESX10-TB-102		ESX10-TB-114*		ESX10-TB-124**		ESX10-TB-127	
Current Rating amps	Circuit Protection Part Number	Current Rating amps	Circuit Protection Part Number	Current Rating amps	Circuit Protection Part Number	Current Rating amps	Circuit Protection Part Number	Current Rating amps	Circuit Protection Part Number	Current Rating amps	Circuit Protection Part Number
0.5	6720005305	0.5	6720005320	0.5	6720005340	0.5	6720005360	0.5	6720005380	0.5	6720005309
1	6720005301	1	6720005321	1	6720005341	1	6720005361	1	6720005381	1	6720005319
2	6720005302	2	6720005322	2	6720005342	2	6720005362	2	6720005382	2	6720005329
3	6720005303	3	6720005323	3	6720005343	3	6720005363	3	6720005383	3	6720005339
4	6720005304	4	6720005324	4	6720005344	4	6720005364	4	6720005384	4	6720005349
6	6720005306	6	6720005326	6	6720005346	6	6720005366	6	6720005386	6	6720005369
8	6720005308	8	6720005328	8	6720005348	8	6720005368	8	6720005388	8	6720005389
10	6720005310	10	6720005330	10	6720005350	10	6720005370	10	6720005390	10	6720005399
12	6720005312	12	6720005332	12	6720005352	12	6720005372	12	6720005392	12	6720005313

ESX10-T Signal inputs / outputs (wiring diagram)

ESX10-TA-100

without signal input/output

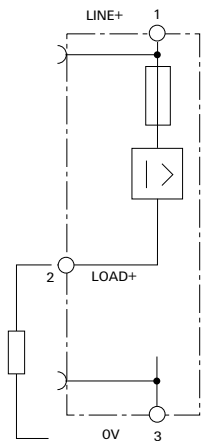

ESX10-TB-101

without signal input
with signal output F
(single signal, N/O)

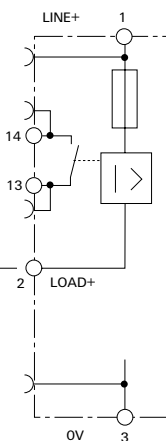

operating condition: 13-14 closed
fault condition: 13-14 open

ESX10-TB-102

without signal input
with signal output F
(single signal, N/C)

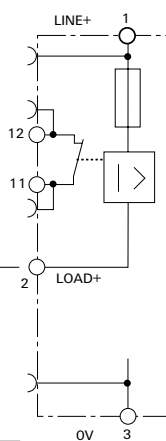

operating condition: 11-12 open
fault condition: 11-12 closed

ESX10-TB-114

with control input IN+
(+24VDC)
with status output SF
(+24 V = load output ON)

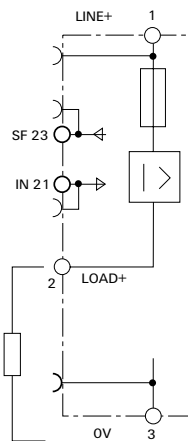

operating condition: SF +24 V = 0K
fault condition: SF 0 V

ESX10-TB-124

with reset input RE
(+24VDC+))
with status output SF
(+24 V = load output ON)

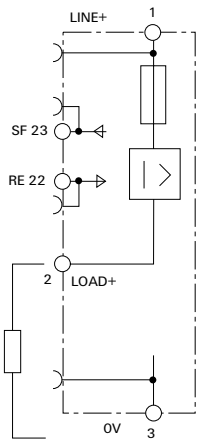

operating condition: SF +24 V = 0
fault condition: SF 0 V

ESX10-TB-127

with reset input RE
(+DC 24 V ↓)
with inverse status output SF
(0 V = load output ON)

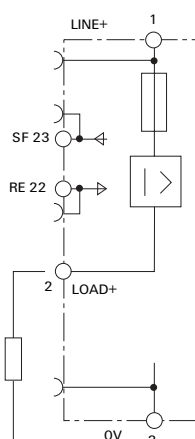

operating condition: SF 0 V = 0K
fault condition: SF +24 V

Dimensions

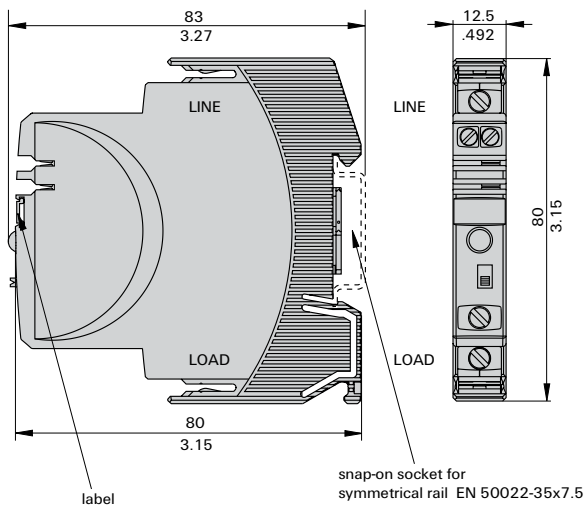

This is a metric design and millimeter dimensions take precedence ($\frac{mm}{inch}$)

Time/Current characteristic curve (Ta = 25 °C)

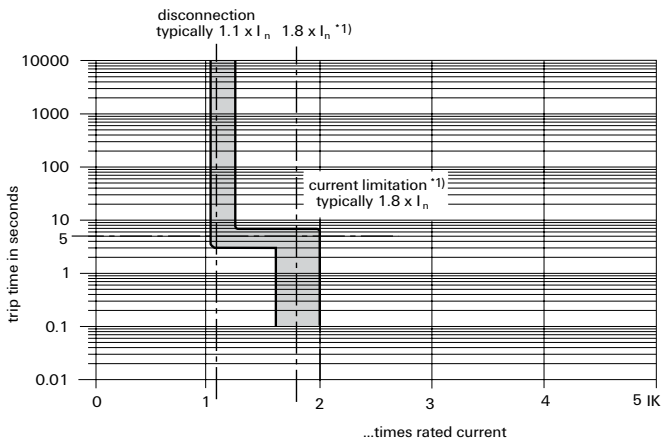

- The trip time is typically 3 s in the range between 1.1 and 1.8 x In¹⁾.
- Electronic current limitation occurs at typically 1.8 x In¹⁾ which means that under all overload conditions (independent of the power supply and the resistance of the load circuit) the max. overload before disconnection will not exceed 1.8 x In¹⁾ times the current rating. Trip time is between 100 ms and 3 sec (depending on overload or at short circuit).
- Without this current limitation a considerably higher overload current would flow in the event of an overload or short circuit.

¹⁾ current limitation typically 1.8 x In times rated current at In = 0.5 A...6 A
 current limitation typically 1.5 x In times rated current at In = 8 A or 10 A
 current limitation typically 1.3 x In times rated current at In = 12 A

Table 4: Reliable trip of ESX10-T

Reliable trip of ESX10-T with different cable lengths and cross sections									
Resistivity of copper ρ ₀ =		0.0178 (Ohm x mm ²) / m							
U _b = DC 19.2 V (= 80 % of 24 V)		voltage drop of ESX10-T and tolerance of trip point (typically 1.1 x In = 1.05 ... 1.35 x In) have been taken into account.							
ESX10-T-selected rating In (in A)	→	3	6	→ ESX10-T trips after 3 s					
e. g. trip current I _{ab} = 1.25 x In (in A)	→	3.75	7.5						
R _{max} in Ohm = (U _b / I _{ab}) - 0.050	→	5.07	2.51						
The ESX10-T reliably trips from 0 Ohm to max. circuitry resistance Rmax									
	Cable cross section A in mm ²	0.14	0.25	0.34	0.5	0.75	1	1.5	
	cable length L in meter (= single length)	cable resistance in Ohm = (R ₀ x 2 x L) / A							
	5	1.27	0.71	0.52	0.36	0.24	0.18	0.12	
	10	2.54	1.42	1.05	0.71	0.47	0.36	0.24	
	15	3.81	2.14	1.57	1.07	0.71	0.53	0.36	
	20	5.09	2.85	2.09	1.42	0.95	0.71	0.47	
	25	6.36	3.56	2.62	1.78	1.19	0.89	0.59	
	30	7.63	4.27	3.14	2.14	1.42	1.07	0.71	
	35	8.90	4.98	3.66	2.49	1.66	1.25	0.83	
	40	10.17	5.70	4.19	2.85	1.90	1.42	0.95	
	45	11.44	6.41	4.71	3.20	2.14	1.60	1.07	
	50	12.71	7.12	5.24	3.56	2.37	1.78	1.19	
	75	19.07	10.68	7.85	5.34	3.56	2.67	1.78	
	100	25.34	14.24	10.47	7.12	4.75	3.56	2.37	
	125	31.79	17.80	13.09	8.90	5.93	4.45	2.97	
	150	38.14	21.36	15.71	10.68	7.12	5.34	3.56	
	175	44.50	24.92	18.32	12.46	8.31	6.23	4.15	
	200	50.86	28.48	20.94	14.24	9.49	7.12	4.75	
	225	57.21	32.04	23.56	16.02	10.68	8.01	5.34	
	250	63.57	35.60	26.18	17.80	11.87	8.90	5.93	
Example 1:	max. length at 1.5 mm ² and 3 A	214 m →							
Example 2:	max. length at 1.5 mm ² and 6 A	106 m →							
Example 3:	mixed wiring: (Control cabinet - sensor/actuator level)	R1 = 40 m in 1.5 mm ² and R2 = 5 m in 0.25 mm ² : R1 = 0.95 Ohm, R2 = 0.71 Ohm Total (R1 + R2) = 1.66 Ohm							

Mounting examples for ESX10-T

The ESX10-T features an integral power distribution system.

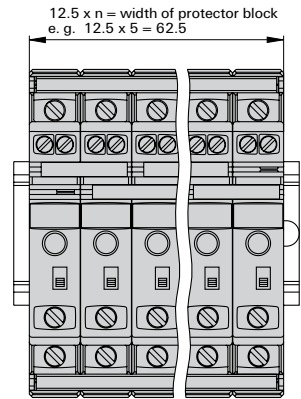
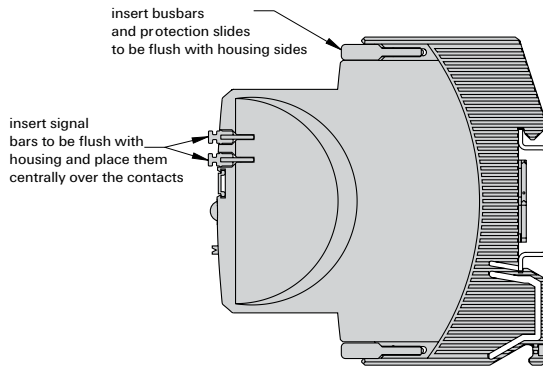
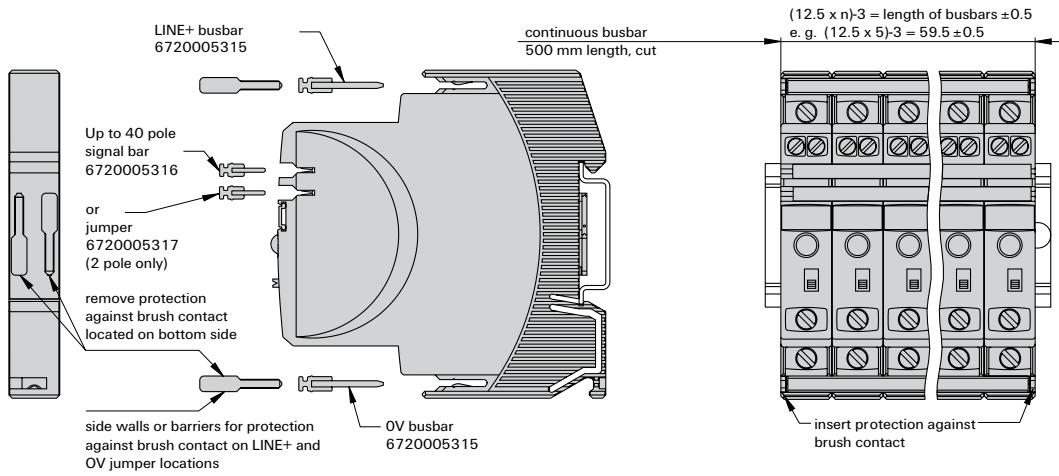

5 ESX10-TB with busbars and jumpers

5 ESX10-TA with busbars

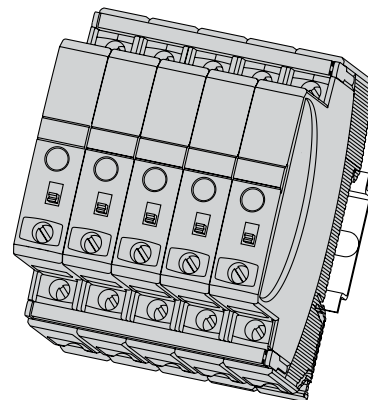
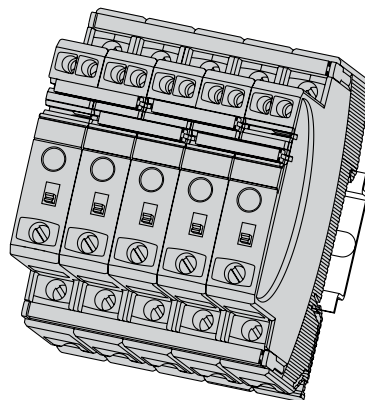

Mounting procedure:
Before wiring insert busbars into protection block.

Connection diagrams and application examples ESX10-T

Signal contacts are shown in OFF or fault condition.

ESX10-TA-100

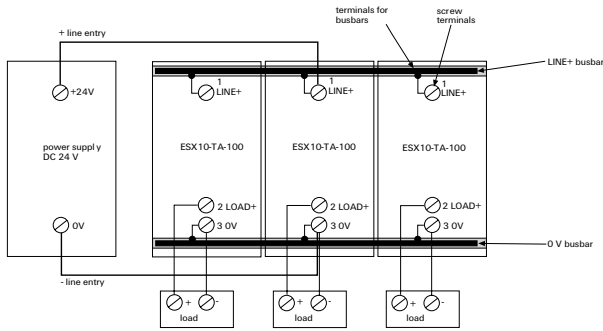

ESX10-TB-101

group signaling (series connection)

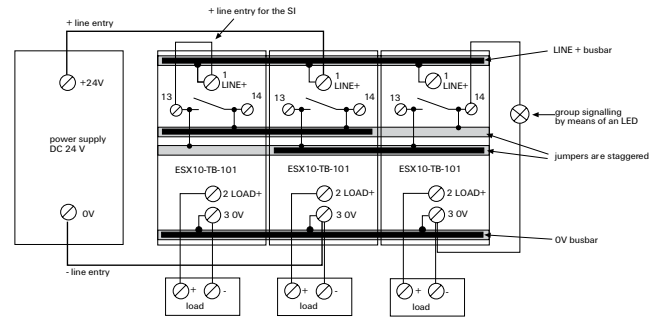

ESX10-TB-102

Single signaling with common line entry

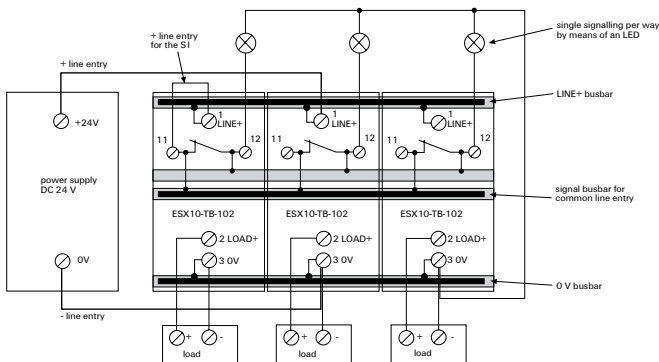

ESX10-TB-124

Single signaling with common reset

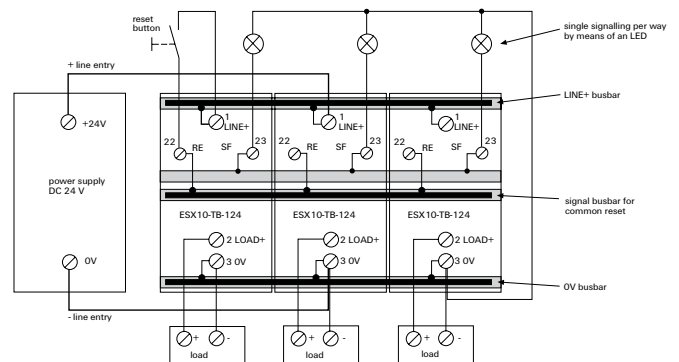

Accessories for ESX10-T

Description

The ESX10-T features an integral power distribution system. The following wiring modes are possible with various pluggable current and signal busbars:

- LINE +(24VDC)
- 0 V

Caution: The electronic devices ESX10-T require a 0 V connection

- signal contacts
- reset inputs

Description	Part No.
Busbars for LINE+ and 0 V	6720005315
max. load with one line entry (recommended: centre line entry)	I_{max} 50 A
max. load with two line entries	I_{max} 63 A
length:	500 mm
Signal busbars for signal contacts and reset inputs	6720005316
max. load with one line entry	I_{max} 1 A
with one series connection of signal contacts	I_{max} 0.5 A
length:	500 mm
Jumpers for signal contacts	6720005317
length:	21 mm
packing unit:	10 pcs
TS32 rail adapter	9102100000

(Remove protection walls/barriers before using adapter.)

For detailed installation instructions and approvals contact Weidmüller at 1-800-849-9343 or go to www.weidmuller.com

Busbars for LINE+ and 0 V

max. load with one line entry (recommended: centre line entry)
max. load with two line entries
grey insulation, length: 500 mm
6720005315

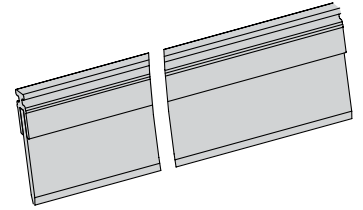

Busbars for LINE+ and 0 V

grey insulation
max. number of plug-on operations 10:
6720005335, (3-unit-block ESX10-T), length: 34.5 mm
6720005336, (4-unit-block ESX10-T), length: 47 mm
6720005337, (5-unit-block ESX10-T), length: 59.5 mm
packing unit: 10 pcs
6720005474, (8-unit-block ESX10-T), length: 97 mm
6720005475, (10-unit-block ESX10-T), length: 122 mm
packing unit: 4 pcs

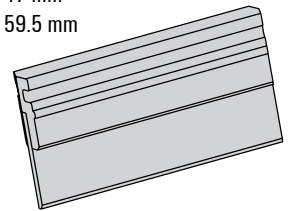

Connector bus link -K10

suitable for auxiliary contacts (series connection)
6720005476 (1.5 mm², brown)

50 pin lugs to DIN 46230 tinned copper

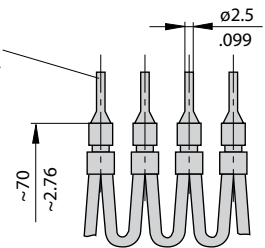

Supply module for LINE+ and 0 V

suitable for ESX10-T... versions
ampacity I_{max} 50 A
AD-TX-EM01

I_{max} 50A

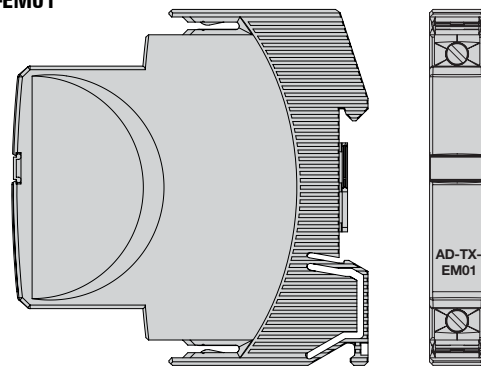

Electronic Circuit Protection

ESX10-TC 12VDC

Electronic circuit protection type ESX10-TC is designed to ensure selective disconnection of 12VDC load systems.

12VDC power supplies, which are widely used in industry today, will shut down the output in the event of an overload with the result that one faulty load in the system can lead to complete disconnection of all loads.

Through selective disconnection the ESX10-TC responds much faster to overload or short circuit conditions than the switch-mode power supply. This is achieved by active current limitation. The ESX10-TC limits the highest possible current to 1.3 to 1.8 times the selected rated current of the circuit protector. Thus it is possible to switch on capacitive loads of up to 20,000 μ F, but they are disconnected only in the event of an overload or short circuit.

For optimal alignment with the characteristics of the application the current rating of the ESX10-TC can be selected in fixed values from 1.0 A...10 A. Failure and status indication are provided by a multicolor LED and an integral short-circuit-proof status output or a relay signal contact. Remote operation is possible by means of a remote reset signal or a remote ON/OFF control signal. The manual ON/OFF button allows separate actuation of individual load circuits.

The ESX10-TC, with a width of only 12.5 mm, can be snapped onto symmetrical rails for easy installation and control cabinet space savings.

Upon detection of overload or short circuit in the load circuit, the MOSFET of the load output will be blocked to interrupt the current flow. The load circuit can be re-activated via the remote electronic reset input, control input or manually by means of the ON/OFF button.

Features

- Selective load protection, electronic trip characteristics
- Active current limitation for safe connection of capacitive loads up to 20,000 μ F and on overload/short circuit
- Current ratings 1 A...10 A at 12VDC
- Reliable overload disconnection with $1.1 \times I_{n\text{ plus}}$, even with long load lines or small cable cross sections (see table 3)
- Manual ON/OFF button (S1)
- Control input IN+ for remote ON/OFF signal (option)
- Electronic **reset** input RE (option)
- Clear status and failure indication through LED, status output SF
- Integral fail-safe element adjusted to current rating
- Width per unit only 12.5 mm
- Rail mounting
- Ease of wiring through busbar LINE+ and 0 V
- Hazardous area approved- Class 1 Div 2, Zone 2 (ATEX)



Technical Data (T_{ambient} = 25°C, operating voltage U_S = 12VDC)

Operating data	
Operating voltage U _B	12VDC (9...18 V)
Current rating I _N	fixed current ratings: 1 A, 2 A, 3 A, 4 A, 6 A, 10 A
Closed current I _Q	ON condition: typically 20...30 mA depending on signal output
Status indication by means of	<ul style="list-style-type: none"> multicolor LED: <ul style="list-style-type: none"> GREEN: unit is ON, power-MOSFET is switched on - status output SF ON, supplies + 12VDC ORANGE: in the event of overload or short circuit until electronic disconnection RED: - unit electronically disconnected - load circuit/Power-MOSFET OFF - low voltage (< 3.25 V) - after switch-on till the end of switch-on delay OFF: - manually switched off (S1 = OFF) or device is dead - undervoltage status output SF (option) ON/OFF/ condition of switch S1
Load circuit	
Load output	Power-MOSFET switching output (high side switch)
Overload disconnection	typically 1.1 x I _N (1.05...1.35 x I _N)
Short-circuit current I _K	active current limitation (see table 1)
Trip time for electronic disconnection	see time/current characteristics typically 3 s at I _{Load} > 1.1 x I _N typically 3 s...50 ms at I _{Load} > 1.8 x I _N (or 1.5 x I _N /1.3 x I _N)
Temperature disconnection	internal temperature monitoring with electronic disconnection
Low voltage monitoring load output	with hysteresis at voltage dips < 500 ms, no reset required: load "OFF" at U _B < 3.2 V
Starting delay t _{start}	typically 10 ms
Disconnection of load circuit	electronic disconnection
Free-wheeling circuit	external free-wheeling diode recommended with inductive load
Several load outputs must not be connected in parallel	

Technical Data (T_{ambient} = 25°C, operating voltage U_S = 12VDC)

Status output SF	
Electrical data	ESX10-TC-114/-124/ plus-switching signal output, connects U _S to terminal 12 of module 17 plus nominal data: 12VDC / max. 0.2 A (short circuit proof) status output is internally connected to GND with a 10 kΩ resistor
Status OUT	ESX10-TC-114/-124 (signal status OUT), +12 V = S1 is ON, load output connected through OV = S1 is ON, load output blocked and/or switch S1 is OFF red LED lit
OFF condition	0 V level at status output when: <ul style="list-style-type: none"> switch S1 is in ON position, but device is still in switch-on delay switch S1 is OFF, or control signal OFF, device is switched off no operating voltage U_S
Reset input RE	
Electrical data	ESX10-TC-124 voltage: max. +32VDC high > 4.5VDC ≤ 18VDC low ≤ 2.5VDC > 0 V power consumption typically 1.4 mA (+12VDC) min. pulse duration typically 10 ms
Reset signal RE (terminal 22)	The electronically blocked ESX10-TC-124 may remotely be reset via an external momentary switch due to the falling edge of a +12 V pulse. A common reset signal can be applied to several devices simultaneously. Switched on devices remain unaffected.
Control input IN+	
Electrical data	ESX10-TC-114 see reset input RE
Control signal IN+ (terminal 21)	+12V level (HIGH): device will be switched on by a remote ON/OFF signal 0 V level (LOW): device will be switched off by a remote ON/OFF signal
Switch S1 ON/OFF	unit can only be switched on with S1 if a HIGH level is applied to IN+

Technical Data (T_{ambient} = 25°C, operating voltage U_S = 12VDC)

General data	
Fail-safe element:	backup fuse for ESX10-T not required because of the integral redundant fail-safe element
Terminals	
LINE+ / LOAD+ / 0V	
screw terminals	M4
max. cable cross section	
flexible with wire end ferrule w/wo plastic sleeve	20-6 AWG (0.5 - 10 mm ²)
multi-lead connection (2 identical cables)	
rigid/flexible	20-11 AWG (0.5 - 4 mm ²)
flexible with wire end ferrule without plastic sleeve	20-13 AWG (0.5 - 2.5 mm ²)
flexible with TWIN wire end ferrule with plastic sleeve	20-9 AWG (0.5 - 6 mm ²)
wire stripping length	10 mm
tightening torque (EN 60934)	1.2 Nm
Terminals	
aux. contacts	
screw terminals M3	
max. cable cross section	
flexible with wire end ferrule w/wo plastic sleeve	23-13 AWG (0.25 - 2.5 mm ²)
wire stripping length	8 mm
tightening torque (EN 60934)	0.5 Nm
Housing material	moulded

Mounting	symmetrical rail to EN 50022-35x7.5
Ambient temperature	-20...+60 °C (without condensation, see EN 60204-1) (with condensation upon request)
Storage temperature	-20...+70 °C
Humidity	96 hrs/95 % RH/40 °C to IEC 60068-2-78-Cab climate class 3K3 to EN 60721
Vibration	3 g, test to IEC 68-2-6 test Fc
Degree of protection	housing: IP20 DIN 40050 terminals: IP20 DIN 40050
EMC	emission: EN 61000-6-3
(EMC directive, CE logo)	susceptibility: EN 61000-6-2
Insulation co-ordination (IEC 60934)	0.5 kV/2 pollution degree 2 re-inforced insulation in operating area
dielectric strength	max. 18VDC (load circuit)
Insulation resistance (OFF condition)	n/a, only electronic disconnection
Dimensions (W x H x D)	12.5 x 80 x 83 mm
Mass	approx. 65 g

Table 1: voltage drop, current limitation, max. load current

current rating I _N	typically voltage drop U _{on} at I _N	active current limitation (typically)	max. load current at 100% ON duty	
			T _u = 40 °C	T _u = 50 °C
1 A	80 mV	1.8 x I _N	1 A	1 A
2 A	130 mV	1.8 x I _N	2 A	2 A
3 A	80 mV	1.8 x I _N	3 A	3 A
4 A	100 mV	1.8 x I _N	4 A	4 A
6 A	130 mV	1.8 x I _N	6 A	5 A
10 A	150 mV	1.5 x I _N	10 A	9 A

Attention: when mounted side-by-side without convection the ESX10-TC should not carry more than 80% of its rated load with 100% ON duty due to thermal effects.

Please note:

- The user should ensure that the cable cross sections of the relevant load circuit are suitable for the current rating of the ESX10-TC used.
- Automatic start-up of machinery after shut down must be prevented (Machinery Directive 98/37/EG and EN 60204-1). In the event of a short circuit or overload the load circuit will be disconnected electronically by the ESX10-TC.
- Refer to UL file for proper wiring and installation techniques.

Table 2: ESX10-TC - Ordering Information

Version	Signal input		Signal output
	Control input ON/OFF Reset	Remote Reset	
ESX10-TC-114	x		Status OUT Positive 12V = OK x
ESX10-TC-124		x	x

Table 3: Specifications

Protection	to EN6052 housing IP30, terminals IP00
EMC	emitted interference to EN 61000-6-3 noise immunity to EN 61000-6-2
Insulation co-ordination	0.5 kV / pollution degree 2, re-inforced insulation in operating area to IEC60934 / IEC60664
CE logo	to 2004/108/EG and 94/9/EG
UL	UL2367, File No E306740 UL508, File No E322549 UL 1604, File No E320024
ATEX	IEC/EN60079-0 /-14/-15 Ⓔ II 3G Ex nA II B T4 Gc X

ESX10-TC-114*		ESX10-TC-124**	
Current Rating (amps)	Control Input Part Number	Current Rating (amps)	Control Input Part Number
1	6720005351	1	6720005331
2	6720005352	2	6720005471
3	6720005353	3	6720005333
4	6720005354	4	6720005334
6	6720005356	6	6720005472
10	6720005357	10	6720005473

* Control force input on/off

** Reset input only to reset under fault conditions

ESX10-TC Signal inputs / outputs (wiring diagram)

ESX10-TC-114
with control input IN+ (+12VDC)
with status output SF (+12 V = load output ON)

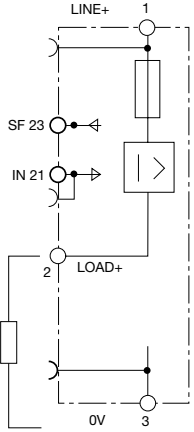

operating condition: SF +12 V = OK
fault condition: SF 0 V

ESX10-TC-124
with reset input RE (+12VDC)
with status output SF (+12 V = load output ON)

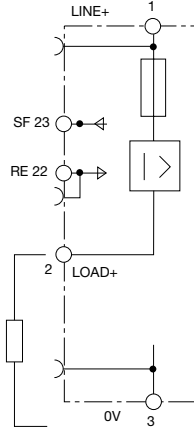

operating condition: SF +12 V = OK
fault condition: SF 0 V

Schematic diagram

(Example)

ESX10-TC-124-...

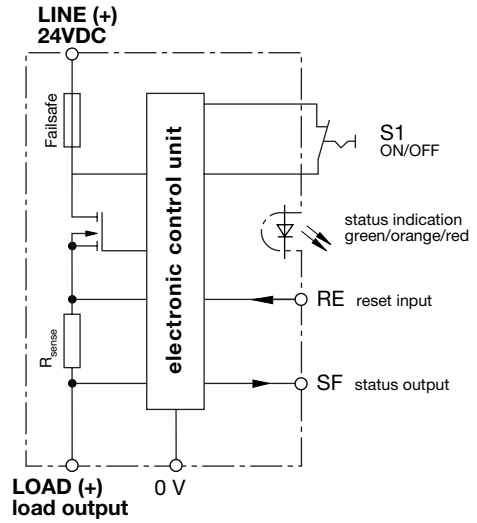

Terminal wiring diagram and dimensions

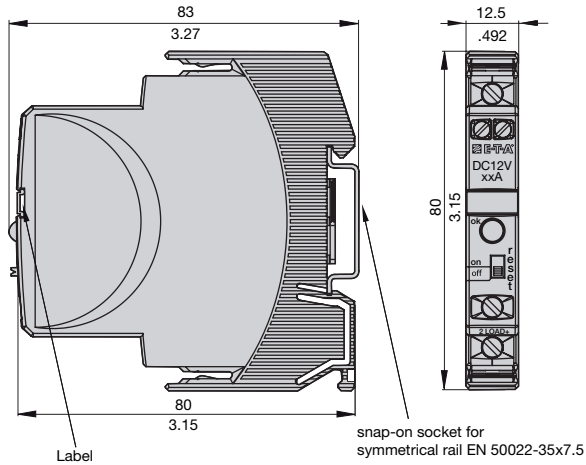

Time/Current characteristic curve (T_a = 25 °C)

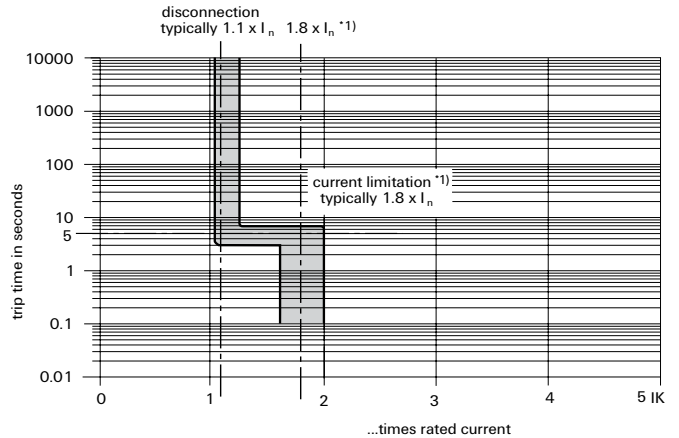

† current limitation typically 1.8 x I_n times rated current at I_n = 1.0 A..6 A
current limitation typically 1.5 x I_n times rated current at I_n = 10 A

- The trip time is typically 3 seconds in the range between 1.1 and 1.8 x I_n†.
- Electronic current limitation occurs at typically 1.8 x I_n† which means that under all overload conditions (independent of the power supply and the resistance of the load circuit) the max. overload before disconnection will not exceed 1.8 x I_n† times the current rating. Trip time is between 100 ms and 3 sec (depending on overload or at short circuit).
- Without this current limitation a considerably higher overload current would flow in the event of an overload or short circuit.

Accessories for ESX10-TC

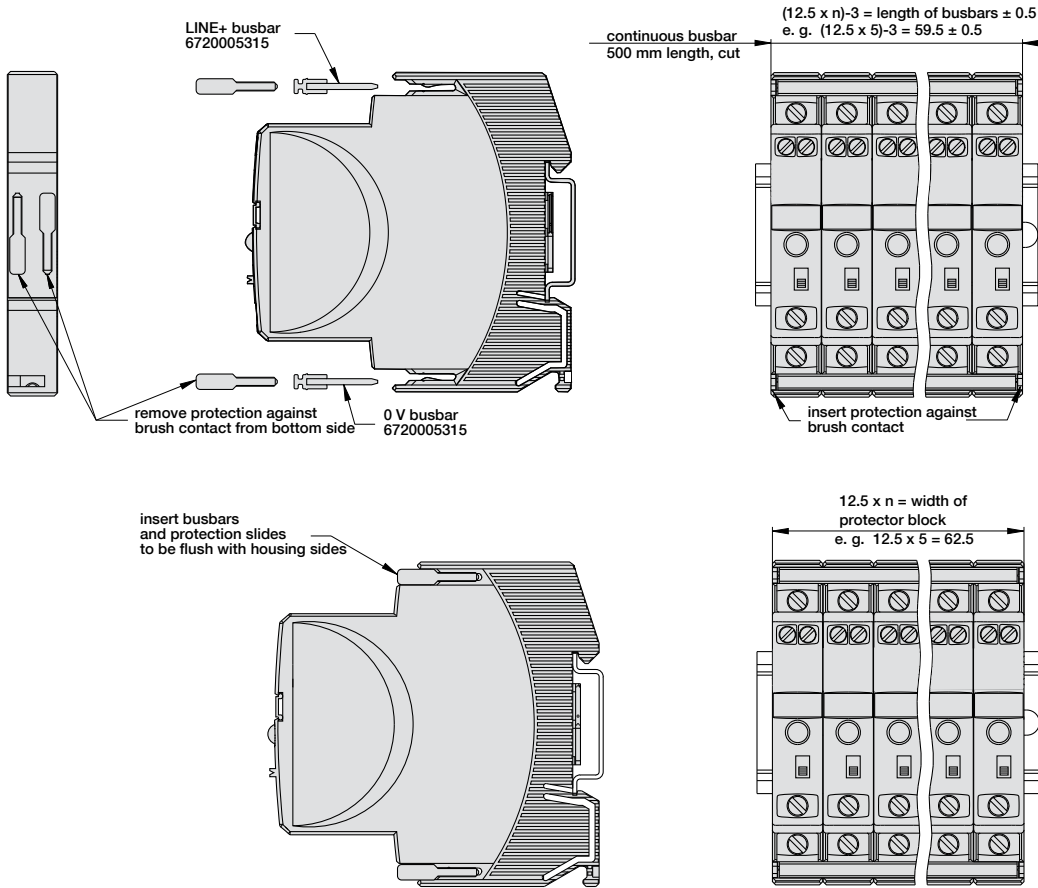

Mounting procedure:

Before wiring, insert busbars into protection block.
 Max. 10 insertion/removal cycles for busbars.

Recommendation:

Every 10 units busbars should be interrupted and fed in anew.

Table of lengths for busbars:

(see accessories)

No. of Units	2	3	4	5	6	7	8	9	10
Length of busbar [mm] + 0.5 mm	22	34.5	47	59.5	72	84.5	97	10.95	122

Accessories for ESX10-TC

The ESX10-TC features an integral power distribution system. The following wiring modes are possible with various pluggable current and signal busbars:

- LINE +(12VDC)
- 0 V

Caution: The electronic devices ESX10-TC require a 0 V connection

Description	Part No.
Busbars for LINE+ and 0 V	6720005315
max. load with one line entry	50 A
(recommended: center line entry) I _{max}	
max. load with two line entries I _{max}	63 A
length:	500 mm

TS32 rail adapter	9102100000
-------------------	-------------------

(Remove protection walls/barriers before using adapter.) For detailed installation instructions and approvals contact Weidmüller at 1-800-849-9343 or go to www.weidmuller.com

Accessories

Busbars for LINE+ and 0 V

max. load with one line entry
(recommended: centre line entry)
max. load with two line entries

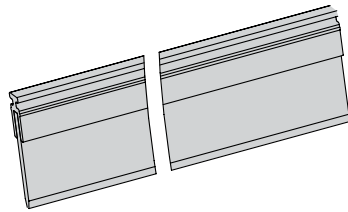

Description	Length	Insulation Color	Part No.
Busbars for LINE+ and 0 V	500mm	Grey	6720005315

Busbars for LINE+ and 0 V

grey insulation
max. number of plug-on operations 10:

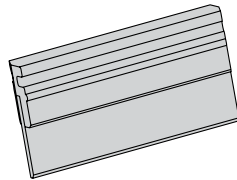

Description	Length	Insulation Color	Packing Unit	Part No.
Busbars for LINE+ and 0 V - (3-unit-block ESX 10-T)	34.5mm	Grey	10	6720005335
Busbars for LINE+ and 0 V - (4-unit-block ESX 10-T)	47mm	Grey	10	6720005336
Busbars for LINE+ and 0 V - (5-unit-block ESX 10-T)	59.5mm	Grey	10	6720005337
Busbars for LINE+ and 0 V - (8-unit-block ESX 10-T)	97mm	Grey	4	6720005474
Busbars for LINE+ and 0 V - (10-unit-block ESX 10-T)	122mm	Grey	4	6720005475

Connector bus link - K10

suitable for auxiliary contacts (series connection)

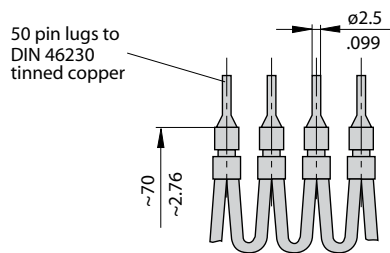

Description	Length	Insulation Color	Part No.
Connector bus link - K10	1.5mm ²	Brown	6720005476

Supply module for LINE+ and 0 V

suitable for ESX10-T... versions

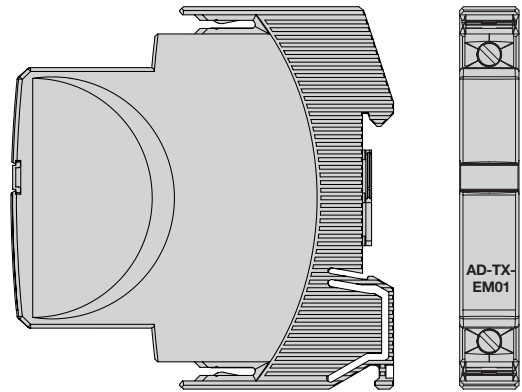

Description	I _{max}	Part No.
Supply module for LINE+ and 0 V	50A	AD-TX-EM01

SPD II 1 - Surge Protectors for AC Power Distribution

SPD II PV - Surge Protectors for DC Photovoltaic Installations



Weidmüller's SPD II 1 series transient voltage surge protectors consist of a range of innovative, compact modules for the protection of low voltage AC distribution systems or (PV models) for DC photovoltaic installations. In AC applications, the SPD II 1 would be installed downstream of the main circuit breaker and fuse(s), connected between each live conductor to be protected and ground. For multi-phase circuits, multiple modules are used with jumper options between ground terminals and permitting a single connection to ground. In photovoltaic applications, the SPD II 1 PV would typically be in a combiner enclosure protecting the DC output and return conductor to ground.

Voltage limiting technology is integrated, which differentiates between transient pulses and longer-lasting overvoltages. This circuitry eliminates the disadvantages of varistor devices (MOVs) which, in competitive products, may switch-on inadvertently in conditions where the supply voltage is not well-regulated. Weidmüller's hybrid arrester design ensures efficient MOV operation and hence conserves energy, maximizes the operating lifetime of the arrester and eliminates arcing when the thermal disconnect operates.

Each module is a two-part construction, comprising a TS35 DIN-rail mountable base and a pluggable replaceable arrester, with each single-conductor assembly only 18mm wide. Products are specified by their working voltage level, or maximum continuous operating voltage (MCOV) and each has a maximum surge current rating of 50kA.

Base/arrester assemblies are available either with or without a remote signaling option and arresters are available as spare parts.

- Models for LV AC distribution or photovoltaic installations
- Quick replacement with spare pluggable, replaceable arresters
- Nominal voltages up to 480VAC (550V MCOV) or 1200VDC
- Maximum surge current (I_{max}) 50kA
- Remote status signaling option
- UL1449 Ed3 approved and CSA equivalent
- No discharge path fuse needed (Type 2)

For transient voltage protection of single and multi-phase circuits, in the main electrical panel, downstream of the main circuit breaker, or in control panels.

SPD II 0 150V/40kA
SPD II 1 150V/40kA
SPD II 1 R 150V/40kA



R model shown

SPD II 0 280V/40kA
SPD II 1 280V/40kA
SPD II 1 R 280V/40kA



R model shown

Technical Data

AC Network
Connection Mode
Max. Operating Voltage (MCOV)
Leakage Current at U _c
Follow Current
UL 1449 Category
UL Nominal Discharge Current (I _n), 15 Impulses 8/20 us
Max. Discharge Current (I _{max}), 1 Impulse 8/20 us
UL Voltage Protection Rating (VPR)
Protection Level (Up)
UL Short-Circuit Current Rating (SCCR)
Sparkover time / Drop-out time
Overcurrent Protection
Connection (network)
Remote Signal Option (Contact Rating)
Mounting
Operating Temp
Operating Altitude (Max.)
Relative Humidity
Enclosure Material
Environmental Rating
Weight (g) and Dimensions (mm)
SPD II 0
SPD II 1
SPD II 1 R

120 V, Single phase
1 Pole, L-N or L-G.
150 VAC
<1mA
None
Type 2
20 kA
50 kA
1.2 kV
≤ 1200 V
200 kA
<100 ns
No fuse required in discharge circuit
Screw connections (2 - 14AWG)
250 V / 0,5 A, 48 VDC /0,1 A
DIN-rail, TS 35
-40°C...+70°C
2,000m
0 - 95% non-condensing
Thermoplastic UL94-V0
IP 20
66 g; 18W x 45H x 60D
138 g; 18W x 90H x 73.5D
142 g; 18W x 100H x 73.5D

230 V, Single phase
1 Pole, L-N or L-G.
277 VAC
<1mA
None
Type 2
20 kA
50 kA
1.6 kV
≤ 1600 V
200 kA
<100 ns
No fuse required in discharge circuit
Screw connections (2 - 14AWG)
250 V / 0,5 A, 48 VDC /0,1 A
DIN-rail, TS 35
-40°C...+70°C
2,000m
0 - 95% non-condensing
Thermoplastic UL94-V0
IP 20
66 g; 18W x 45H x 60D
140 g; 18W x 90H x 73.5D
142 g; 18W x 100H x 73.5D

Approvals

UL 1449 (USA and CANADA)

UL File E354261, Type 2 UL1449 Ed. 3, CSA Electrical Notice No. 516

UL File E354261, Type 2 UL1449 Ed. 3, CSA Electrical Notice No. 516

Ordering Data

Surge Protector
Spare arrester 120V nom.
Spare arrester 230V nom.
SPD assembly w/o relay
SPD assembly with relay
Bus bars
2-pole jumper
3-pole jumper
4-pole jumper

Type	Part No.
SPD II 0 150V/40kA	1348330000
—	—
SPD II 1 150V/40kA	1348340000
SPD II 1 R 150V/40kA.	1348350000
Type	Part No.
QB 18-2	8877540000
QB 18-3	8877500000
QB 18-4	8877520000

Type	Part No.
—	—
SPD II 0 280V/40kA	1348370000
SPD II 1 280V/40kA	1348380000
SPD II 1 R 280V/40kA.	1348390000
Type	Part No.
QB 18-2	8877540000
QB 18-3	8877500000
QB 18-4	8877520000

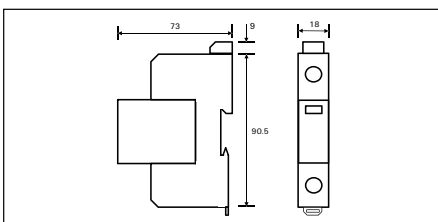

Dimensions

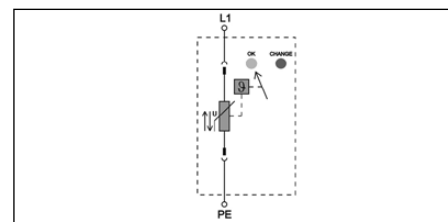

Electrical Function



2-, 3- and 4-pole Jumpers

For transient voltage protection of single and multi-phase circuits, in the main electrical panel, downstream of the main circuit breaker, or in control panels.

SPD II 0 400V/40kA
SPD II 1 400V/40kA
SPD II 1 R 400V/40kA



R model shown

SPD II 0 550V/40kA
SPD II 1 550V/40kA
SPD II 1 R 550V/40kA



R model shown

Technical Data

AC Network	277/347 V, Single phase
Connection Mode	1 Pole, L-N or L-G.
Max. Operating Voltage (MCOV)	385 VAC
Leakage Current at Uc	<1mA
Follow Current	None
UL Category	Type 2
UL Nominal Discharge Current (In), 15 Impulses 8/20 us	20 kA
Max. Discharge Current (Imax), 1 Impulse 8/20 us	50 kA
UL Voltage Protection Rating (VPR)	1.8 kV
Protection Level (Up)	≤ 1800 V
UL Short-Circuit Current Rating (SCCR)	200 kA
Sparkover time / Drop-out time	<100 ns
Overcurrent Protection	No fuse required in discharge circuit
Connection (network)	Screw connections (2 - 14AWG)
Remote Signal (Contact Rating)	250 V / 0,5 A, 48 VDC /0,1 A
Mounting	DIN-rail, TS 35
Operating Temp	-40°C...+70°C
Operating Altitude (Max.)	2,000m
Relative Humidity	0 - 95% non-condensing
Enclosure Material	Thermoplastic UL94-V0
Environmental Rating	IP 20
Weight (g) and Dimensions (mm)	
SPD II 0	66 g; 18W x 45H x 60D
SPD II 1	138 g; 18W x 90H x 73.5D
SPD II 1 R	150 g; 18W x 100H x 73.5D

AC Network	480 V, Single phase
Connection Mode	1 Pole, L-N or L-G.
Max. Operating Voltage (MCOV)	550 VAC
Leakage Current at Uc	<1mA
Follow Current	None
UL Category	Type 2
UL Nominal Discharge Current (In), 15 Impulses 8/20 us	20 kA
Max. Discharge Current (Imax), 1 Impulse 8/20 us	50 kA
UL Voltage Protection Rating (VPR)	2.5 kV
Protection Level (Up)	≤ 2500 V
UL Short-Circuit Current Rating (SCCR)	200 kA
Sparkover time / Drop-out time	<100 ns
Overcurrent Protection	No fuse required in discharge circuit
Connection (network)	Screw connections (2 - 14AWG)
Remote Signal (Contact Rating)	250 V / 0,5 A, 48 VDC /0,1 A
Mounting	DIN-rail, TS 35
Operating Temp	-40°C...+70°C
Operating Altitude (Max.)	2,000m
Relative Humidity	0 - 95% non-condensing
Enclosure Material	Thermoplastic UL94-V0
Environmental Rating	IP 20
Weight (g) and Dimensions (mm)	
SPD II 0	66 g; 18W x 45H x 60D
SPD II 1	138 g; 18W x 90H x 73.5D
SPD II 1 R	150 g; 18W x 100H x 73.5D

AC Network	480 V, Single phase
Connection Mode	1 Pole, L-N or L-G.
Max. Operating Voltage (MCOV)	550 VAC
Leakage Current at Uc	<1mA
Follow Current	None
UL Category	Type 2
UL Nominal Discharge Current (In), 15 Impulses 8/20 us	20 kA
Max. Discharge Current (Imax), 1 Impulse 8/20 us	50 kA
UL Voltage Protection Rating (VPR)	2.5 kV
Protection Level (Up)	≤ 2500 V
UL Short-Circuit Current Rating (SCCR)	200 kA
Sparkover time / Drop-out time	<100 ns
Overcurrent Protection	No fuse required in discharge circuit
Connection (network)	Screw connections (2 - 14AWG)
Remote Signal (Contact Rating)	250 V / 0,5 A, 48 VDC /0,1 A
Mounting	DIN-rail, TS 35
Operating Temp	-40°C...+70°C
Operating Altitude (Max.)	2,000m
Relative Humidity	0 - 95% non-condensing
Enclosure Material	Thermoplastic UL94-V0
Environmental Rating	IP 20
Weight (g) and Dimensions (mm)	
SPD II 0	66 g; 18W x 45H x 60D
SPD II 1	138 g; 18W x 90H x 73.5D
SPD II 1 R	150 g; 18W x 100H x 73.5D

Approvals

UL 1449 (USA and CANADA)

UL File E354261, Type 2 UL1449 Ed. 3, CSA Electrical Notice No. 516

UL File E354261, Type 2 UL1449 Ed. 3, CSA Electrical Notice No. 516

Ordering Data

Surge Protector
Spare arrester 277V nom.
Spare arrester 440/480V nom.
SPD assembly w/o relay
SPD assembly with relay
Bus bars
2-pole jumper
3-pole jumper
4-pole jumper

Type	Part No.
SPD II 0 400V/40kA	1348400000
-	-
SPD II 1 400V/40kA	1348420000
SPD II 1 R 400V/40kA.	1348430000
Type	Part No.
QB 18-2	8877540000
QB 18-3	8877500000
QB 18-4	8877520000

Type	Part No.
-	-
SPD II 0 550V/40kA	1348440000
SPD II 1 550V/40kA	1348450000
SPD II 1 R 550V/40kA.	1348470000
Type	Part No.
QB 18-2	8877540000
QB 18-3	8877500000
QB 18-4	8877520000

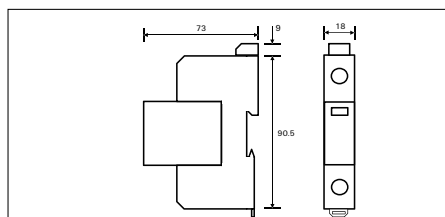

Dimensions

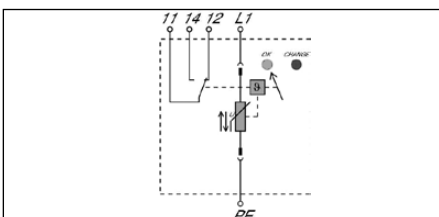

Electrical Function



2-, 3- and 4-pole Jumpers

Basic AC configurations 1 (with remote signaling options)

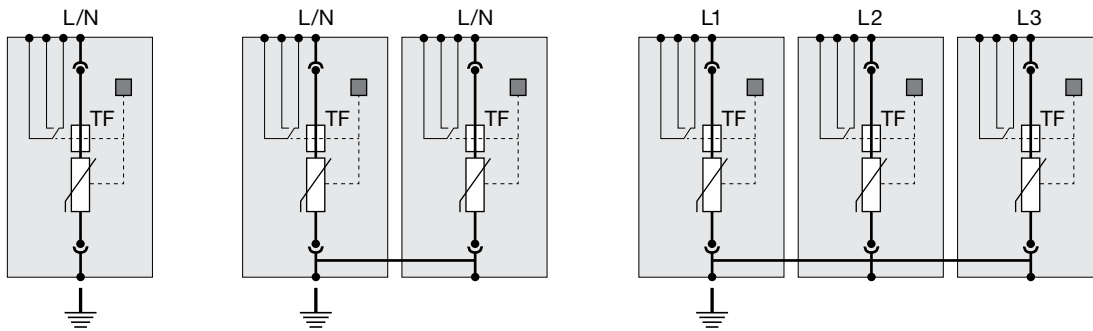

SPD parts needed:

Nom. V	Description	Qty	Qty	Qty	Part No.
110/120V	SPD II 150V/40kA	1	2	3	1348350000
230/240V	SPD II 280V/40kA	1	2	3	1348390000
277V	SPD II 400V/40kA	1	2	3	1348430000
480V	SPD II 550V/40kA	1	2	3	1348470000
All	QB18-2	0	1	0	8877540000
All	QB18-3	0	0	1	8877500000

Basic AC configurations 2 (with remote signaling options)

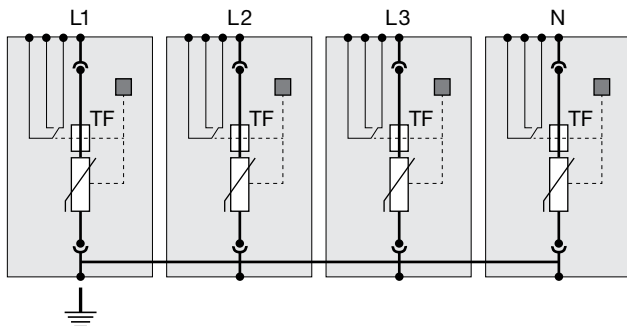

SPD parts needed:

Nom. V	Description	Qty	Part No.
110/120V	SPD II 1 R 150V/40kA	4	1348350000
230/240V	SPD II 1 R 280V/40kA	4	1348390000
277V	SPD II 1 R 400V/40kA	4	1348430000
480V	SPD II 1 R 550V/40kA	4	1348470000
All	QB 18-4	1	8877520000

For use on the DC side of photovoltaic installations, typically in a combiner enclosure, protecting the DC output and return conductor to the ground.

SPD II 0 PV 600VDC
SPD II 2 PV 600VDC
SPD II 2 R PV 600VDC

SPD II 0 PV 1000VDC
SPD II 2 PV 1000VDC
SPD II 2 R PV 1000VDC

SPD II 0 PV 1200VDC
SPD II 3 PV 1200VDC
SPD II 3 R PV 1200VDC



R model shown



R model shown



R model shown

Technical Data

DC Network	600 VDC	1000 VDC	1200 VDC
Connection Mode	Screw connection	Screw connection	Screw connection
Max. Operating Voltage (MCOV)	550 VDC	1000 VDC	1200 VDC
Leakage Current at U _c	<1mA	<1mA	<1mA
UL Category	Type 2	Type 2	Type 2
UL Nominal Discharge Current (I _n), 5 Impulses 8/20 us	20 kA	20 kA	20 kA
Max. Discharge Current (I _{max}), 1 Impulse 8/20 us	50 kA	50 kA	50 kA
UL Voltage Protection Rating (VPR)	2 kV	4 kV	4 kV
Protection Level (Up)	≤ 2000 V	≤ 4000 V	≤ 4000 V
UL Short-Circuit Current Rating (SCCR)	200 kA	200 kA	200 kA
Sparkover time / Drop-out time	<100 ns	<100 ns	<100 ns
Overcurrent Protection	No fuse required in discharge circuit	No fuse required in discharge circuit	No fuse required in discharge circuit
Connection (network)	Screw connection, pluggable	Screw connection, pluggable	Screw connection, pluggable
Remote Signal (Contact Rating)	250 V / 0,5 A, 48 VDC /0,1 A	250 V / 0,5 A, 48 VDC /0,1 A	250 V / 0,5 A, 48 VDC /0,1 A
Mounting	DIN-rail, TS 35, TS 35 x 15, TS 35 x 7.5	DIN-rail, TS 35, TS 35 x 15, TS 35 x 7.5	DIN-rail, TS 35, TS 35 x 15, TS 35 x 7.5
Operating Temp	-40°C...+70°C	-40°C...+70°C	-40°C...+70°C
Operating Altitude (Max.)	2000m	2000m	2000m
Relative Humidity	0 - 95% non-condensing	0 - 95% non-condensing	0 - 95% non-condensing
Enclosure Material	Thermoplastic UL94-V0	Thermoplastic UL94-V0	Thermoplastic UL94-V0
Environmental Rating	IP 20	IP 20	IP 20
Weight (g)	274	292	402
Dimensions (mm)	36W x 100H x 73.5D	36W x 100H x 73.5D	54W x 100H x 73.5D
Approvals			
UL 1449 (USA and CANADA)	UL File E354261, Type 2 UL1449 Ed. 3, CSA Electrical Notice No. 516	UL File E354261, Type 2 UL1449 Ed. 3, CSA Electrical Notice No. 516	UL File E354261, Type 2 UL1449 Ed. 3, CSA Electrical Notice No. 516

Ordering Data

Surge Protector	Type	Part No.	Type	Part No.	Type	Part No.
Spare arrester 600V nom.	SPD II 0 PV 600VDC	1348520000	-	-	-	-
Spare arrester 1000V nom.	-	-	SPD II 0 PV 1000VDC	1348480000	-	-
Spare arrester 1200V nom.	-	-	-	-	SPD II 0 PV 1200VDC	1348550000
PV SPD assembly w/o relay	SPD II 2 PV 600VDC	1348540000	SPD II 2 PV 1000VDC	1348490000	SPD II 3 PV 1200VDC	1348570000
PV SPD assembly with relay	SPD II 2 R PV 600VDC	1348430000	SPD II 2 R PV 1000VDC	1348500000	SPD II 3 R PV 1200VDC	1348580000

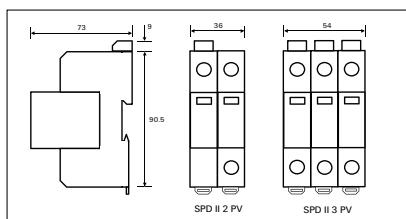

Dimensions

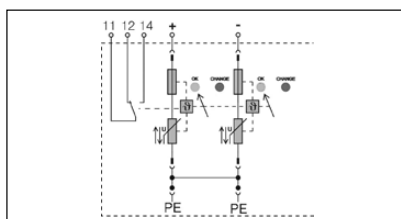

Electrical Function
PSPD II 2 R PV

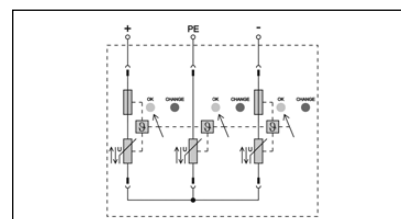

Electrical Function
PSPD II 3 PV

SPD II & III - AC Surge Protector



The SPD II range of surge protectors are used for transient surge protection of single and multi-phase power circuits at the main electrical panel. SPD IIIs are for the protection of individual electrical devices. They provide common-mode protection (between each Line and Ground), with impulse discharge capacity (I_{max}) 40kA for SPD II and 20kA for SPD III.

The SPD design is based on high-energy varistors (MOVs) equipped with thermal disconnects and integral failure indicators. A remote signaling contact for disconnection indication is standard on each unit. For ease of replacement, varistors are housed in pluggable modules with connections that are mechanically keyed to the base to prevent incorrect arrester module replacement.

Typical applications include low voltage distribution or protection of industrial control systems, equipment assemblies and devices.

For transient voltage protection of single and multi-phase circuits, in the main electrical panel, downstream of the main circuit breaker, or in control panels.

SPD II 120V/40kA



SPD II 230V/40kA



Technical Data

AC Network	
Connection Mode	
Max. Operating Voltage (MCOV)	
TOV Withstand	
Leakage Current at Uc	
Follow Current	
UL Nominal Discharge Current (In), 15 impulses 8/20 µs	
Max. Discharge Current (Imax), 1 impulse 8/20 µs	
UL Voltage Protection Rating (VPR)	
Protection Level (Up)	
UL Short-Circuit Current Rating (SCCR)	
AC System	
Thermal Disconnect	
Overcurrent Protection	
Dimensions (mm)	
Connection	
Remote Signal Indicator	
Mounting	
Operating Temp	
Operating Altitude (Max.)	
Relative Humidity	
Enclosure Material	
Environmental Rating	
Weight	

120/240V, 120/208V	
1 Pole, L/N or L-G	
150VAC	
150VAC	
<1mA	
none	
20kA	
40kA	
500V	
0.9kV	
25kAIC	
Single-phase	
UL 60691	
Time Delay - 125A Max.	
90 x 18 x 67	
Screw terminals, #4 AWG Max.	
250VAC Max, 2A	
Din-rail, TS35	
-50°C to +85°C	
13,000 ft (4,000m)	
5 to 95% non-condensing, up to 100% external	
Thermoplastic UL94-V0	
IP20	
3.4 oz	

220/380V, 240/415V	
1 Pole, L/N or L-G	
275VAC	
275VAC	
<1mA	
none	
20kA	
40kA	
900V	
1.25kV	
25kAIC	
Single-phase	
UL 60691	
Time Delay - 125A Max.	
90 x 18 x 67	
Screw terminals, #4 AWG Max.	
250VAC Max, 2A	
Din-rail, TS35	
-50°C to +85°C	
13,000 ft (4,000m)	
5 to 95% non-condensing, up to 100% external	
Thermoplastic UL94-V0	
IP20	
3.4 oz	

Approvals

IEC 61643-1 - INTERNATIONAL
EN 61643-11 - EUROPE
NF EN 61643-11 - FRANCE
UL1449 3rd Edition - USA and CANADA
RoHS

Class I, Class II
Class I, Class II
Class I, Class II
Low Voltage SPD
Directive 2002/95/EC

Class I, Class II
Class I, Class II
Class I, Class II
Low Voltage SPD
Directive 2002/95/EC

Ordering Data

Surge Protector
Bus bars

Type	Part No.
SPD II 120V/40kA	6720005410
Type	Part No.
SPD 2P LINK	6720005417
SPD 3P LINK	6720005418
SPD 4P LINK	6720005419

Type	Part No.
SPD II 230V/40kA	6720005411
Type	Part No.
SPD 2P LINK	6720005417
SPD 3P LINK	6720005418
SPD 4P LINK	6720005419

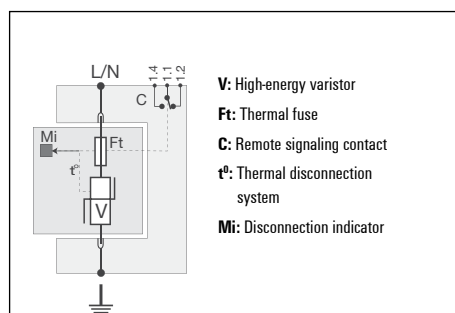
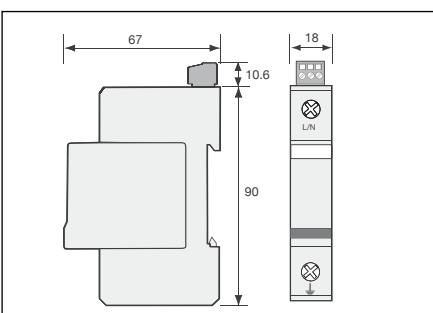

SPD II & III - AC Surge Protectors

For transient voltage protection of single and multi-phase circuits, in the main electrical panel, downstream of the main circuit breaker, or in control panels.

SPD II 277V/40kA



SPD II 480V/40kA



Technical Data

AC Network	220/380V, 277V
Connection Mode	1 Pole, L-N or L-G
Max. Operating Voltage (MCOV)	400VAC
TOV Withstand	400VAC
Leakage Current at Uc	<1mA
Follow Current	none
UL Nominal Discharge Current (In), 15 impulses 8/20 μs	20kA
Max. Discharge Current (Imax), 1 impulse 8/20 μs	40kA
UL Voltage Protection Rating (VPR)	1500V
Protection Level (Up)	1.8kV
UL Short-Circuit Current Rating (SCCR)	25kAIC
AC System	Single-phase
Thermal Disconnect	UL 60691
Overcurrent Protection	Time Delay - 125A Max.
Dimensions (mm)	90 x 18 x 67
Connection	Screw terminals, #4 AWG Max.
Remote Signal Indicator	250VAC Max, 2A
Mounting	Din-rail, TS35
Operating Temp	-50°C to +85°C
Operating Altitude (Max.)	13,000 ft (4,000m)
Relative Humidity	5 to 95% non-condensing, up to 100% external
Enclosure Material	Thermoplastic UL94-V0
Environmental Rating	IP20
Weight	3.4 oz

Approvals

IEC 61643-1 - INTERNATIONAL
EN 61643-11 - EUROPE
NF EN 61643-11 - FRANCE
UL1449 3rd Edition - USA and CANADA
RoHS

Ordering Data

Surge Protector	Type	Part No.
	SPD II 277V/40kA	6720005412

Bus bars	Type	Part No.
	SPD 2P LINK	6720005417
	SPD 3P LINK	6720005418
	SPD 4P LINK	6720005419

AC Network	347/600V, 480V
Connection Mode	1 Pole, L-N or L-G
Max. Operating Voltage (MCOV)	550VAC
TOV Withstand	550VAC
Leakage Current at Uc	<1mA
Follow Current	none
UL Nominal Discharge Current (In), 15 impulses 8/20 μs	20kA
Max. Discharge Current (Imax), 1 impulse 8/20 μs	40kA
UL Voltage Protection Rating (VPR)	1800V
Protection Level (Up)	2.5kV
UL Short-Circuit Current Rating (SCCR)	25kAIC
AC System	Single-phase
Thermal Disconnect	UL 60691
Overcurrent Protection	Time Delay - 125A Max.
Dimensions (mm)	90 x 18 x 67
Connection	Screw terminals, #4 AWG Max.
Remote Signal Indicator	250VAC Max, 2A
Mounting	Din-rail, TS35
Operating Temp	-50°C to +85°C
Operating Altitude (Max.)	13,000 ft (4,000m)
Relative Humidity	5 to 95% non-condensing, up to 100% external
Enclosure Material	Thermoplastic UL94-V0
Environmental Rating	IP20
Weight	3.4 oz

AC Network	347/600V, 480V
Connection Mode	1 Pole, L-N or L-G
Max. Operating Voltage (MCOV)	550VAC
TOV Withstand	550VAC
Leakage Current at Uc	<1mA
Follow Current	none
UL Nominal Discharge Current (In), 15 impulses 8/20 μs	20kA
Max. Discharge Current (Imax), 1 impulse 8/20 μs	40kA
UL Voltage Protection Rating (VPR)	1800V
Protection Level (Up)	2.5kV
UL Short-Circuit Current Rating (SCCR)	25kAIC
AC System	Single-phase
Thermal Disconnect	UL 60691
Overcurrent Protection	Time Delay - 125A Max.
Dimensions (mm)	90 x 18 x 67
Connection	Screw terminals, #4 AWG Max.
Remote Signal Indicator	250VAC Max, 2A
Mounting	Din-rail, TS35
Operating Temp	-50°C to +85°C
Operating Altitude (Max.)	13,000 ft (4,000m)
Relative Humidity	5 to 95% non-condensing, up to 100% external
Enclosure Material	Thermoplastic UL94-V0
Environmental Rating	IP20
Weight	3.4 oz

Approvals	Class I, Class II
	Class I, Class II
	Class I, Class II
	Class I, Class II
	Low Voltage SPD
	Directive 2002/95/EC

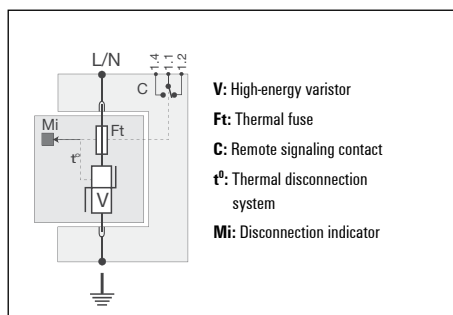
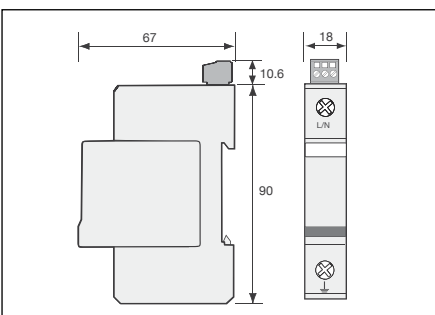

SPD II bus bars

For transient voltage protection of multi-phase circuits with TT grounding systems.

SPD II N/PE



Technical Data

Network	230/400V, 120/208V
Max. Operating Voltage (MCOV)	255VAC
TDV Withstand	400VAC
Leakage Current at Uc	none
Follow Current	100A
Nominal Discharge Current (In), 15 impulses 8/20 µs	20kA
Max. Discharge Current (Imax), 1 impulse 8/20 µs	40kA
Protection Level (Up)	1.5kV
UL Short-Circuit Current Rating (SCCR)	25kAIC
Dimensions (mm)	90 x 18 x 67
Connection	Screw terminals, #4 AWG Max.
Mounting	Din-rail, TS35
Operating Temp	-40°C to +85°C
Enclosure Material	Thermoplastic UL94-V0
Environmental Rating	IP20
Approvals	
IEC 61643-1 - INTERNATIONAL	Class II
EN 61643-11 - EUROPE	Class II
NF EN 61643-11 - FRANCE	Class II
UL1449 3rd Edition - USA and CANADA	Low Voltage SPD

Ordering Data

Surge Protector	Type	Part No.
	SPD II N/PE	6720005414
Bus bars	Type	Part No.
	SPD S LINK 1/3	6720005461

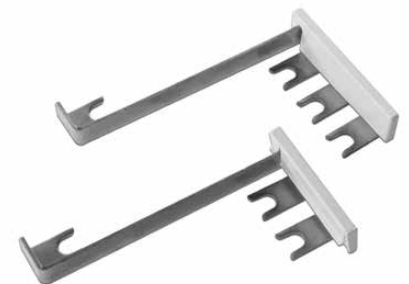
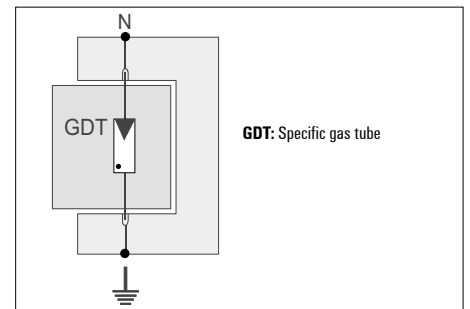
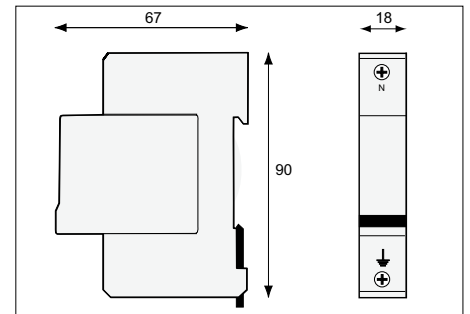

SPD II bus bars



For devices with single phase voltage supplies

- Protects L & N conductors (common and differential modes)
- Integrated contact for remote status indication
- Local status indicator on arrester
- Quick replacement with pluggable arrester

SPD II 120V/G/40kA



SPD II 240V/G/40kA



Technical Data

AC Network	120V
Connection Mode	TN-TT
Max. Operating Voltage (MCOV)	150VAC
TDV Withstand	150VAC
Leakage Current at Uc	<1mA
Protection Mode	MC/MD
Nominal Discharge Current (In), 15 impulses 8/20 µs	20kA
Max. Discharge Current (Imax), 1 impulse 8/20 µs	40kA
Protection Level (Up)	1.5/0.9kV
Residual Voltage @ 5k	0.6kV
Short-Circuit Current Rating (SCCR)	10kAIC
AC System	Single-phase
Thermal Disconnecter	Internal
Overcurrent Protection	Fuses type gG 50A Max.
Dimensions (mm)	90 x 18 x 58
Connection	Screw terminals, #4AWG Max.
Disconnection Indicator	2 mechanical indicators
Installation Ground Fault Breaker	Type S or delayed
Mounting	Din-rail, TS35
Operating Temp	-40°C to +85°C
Operating Altitude	13,000 ft (4,000m)
Relative Humidity	5 to 95% non-condensing, up to 100% external
Enclosure Material	Thermoplastic UL94-V0
Environmental Rating	IP20
Weight	3.4 oz
Approvals	
IEC 61643-1 - INTERNATIONAL	Low Voltage SPD - Test Class II
EN 61643-11 - EUROPE	Low Voltage SPD - Test Class II
NF EN 61643-11 - FRANCE	Low Voltage SPD - Test Class II
UL1449 3rd Edition - USA and CANADA	UL file E338172, CSA file 253665

120V
TN-TT
150VAC
150VAC
<1mA
MC/MD
20kA
40kA
1.5/0.9kV
0.6kV
10kAIC
Single-phase
Internal
Fuses type gG 50A Max.
90 x 18 x 58
Screw terminals, #4AWG Max.
2 mechanical indicators
Type S or delayed
Din-rail, TS35
-40°C to +85°C
13,000 ft (4,000m)
5 to 95% non-condensing, up to 100% external
Thermoplastic UL94-V0
IP20
3.4 oz
Low Voltage SPD - Test Class II
Low Voltage SPD - Test Class II
Low Voltage SPD - Test Class II
UL file E338172, CSA file 253665

230V
TN
255VAC
255VAC
<1mA
MC/MD
20kA
40kA
1.5/1.25kV
0.9kV
10000 A
Single-phase
Internal
Fuses type gG 50A Max.
90 x 18 x 67
Screw terminals, #4AWG Max.
2 mechanical indicators
Type S or delayed
Din-rail, TS35
-40°C to +85°C
13,000 ft (4,000m)
5 to 95% non-condensing, up to 100% external
Thermoplastic UL94-V0
IP20
3.4 oz
Low Voltage SPD - Test Class
Low Voltage SPD - Test Class
Parafoudre Basse Tension - Essais Classe
UL file E338172, CSA file 253665

Ordering Data

Surge Protector
Bus bars

Type	Part No.
SPD II 120V/G/40kA	6720005415
Type	Part No.
SPD 2P LINK	6720005417
SPD 3P LINK	6720005418
SPD 4P LINK	6720005419

Type	Part No.
SPD II 240V/G/40kA	6720005403
Type	Part No.
SPD 2P LINK	6720005417
SPD 3P LINK	6720005418
SPD 4P LINK	6720005419

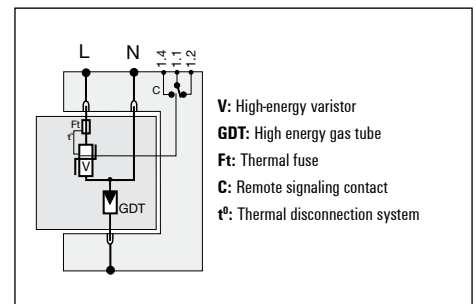
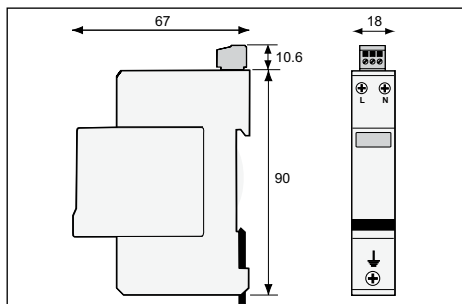

For transient voltage protection of single-phase devices.

- Protects 2 conductors - typically L & N, but could also be L1 & L2
- Integrated contact for remote status indication
- Pluggable replaceable arrester

SPD III 120V/40kA



Technical Data

AC Network	120V
Connection Mode	TN
Max. Operating Voltage (MCOV)	150VAC
TOV Withstand	150VAC
Max load current	16A
Leakage Current at Uc	<1mA
Follow Current	none
Nominal Discharge Current (In), 15 impulses 8/20 μs	20kA
Max. Discharge Current (Imax), 1 impulse 8/20 μs	40kA
Protection Level (Up)	1.5/0.9kV
Short-Circuit Current Rating (SCCR)	10kAIC
AC System	Single-phase
Thermal Disconnecter	UL 60691 Internal
Overcurrent Protection	Fuses type gG - 50A Max.
Dimensions (mm)	90 x 18 x 58
Connection	Screw terminals, #4 AWG Max.
Remote Signal Indicator	250VAC Max, 2A
Mounting	Din-rail, TS35
Operating Temp	-40°C to +85°C
Operating Altitude	13,000 ft (4,000m)
Relative Humidity	5 to 95% non-condensing, up to 100% external
Enclosure Material	Thermoplastic UL94-V0
Environmental Rating	IP20
Weight	3,4 oz
Approvals	
IEC 61643-1 - INTERNATIONAL	Class II, Class III
EN 61643-11 - EUROPE	Class II, Class III
NF EN 61643-11 - FRANCE	Class II, Class III
UL1449 3rd Edition - USA and CANADA	UL file E338172, file 253665

Ordering Data

Surge Protector	Type	Part No.
	SPD III 120V/40kA	6720005416

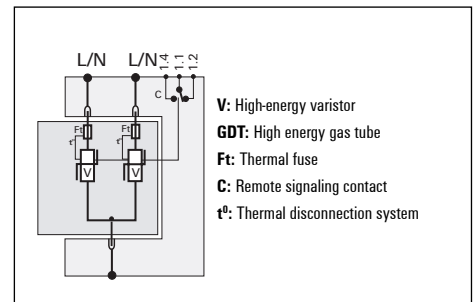
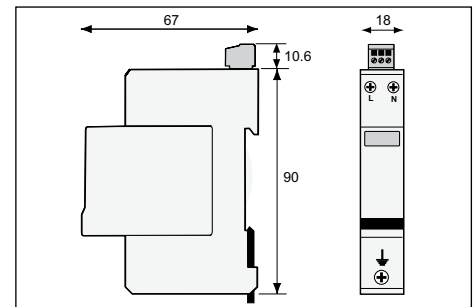

Basic configurations 1

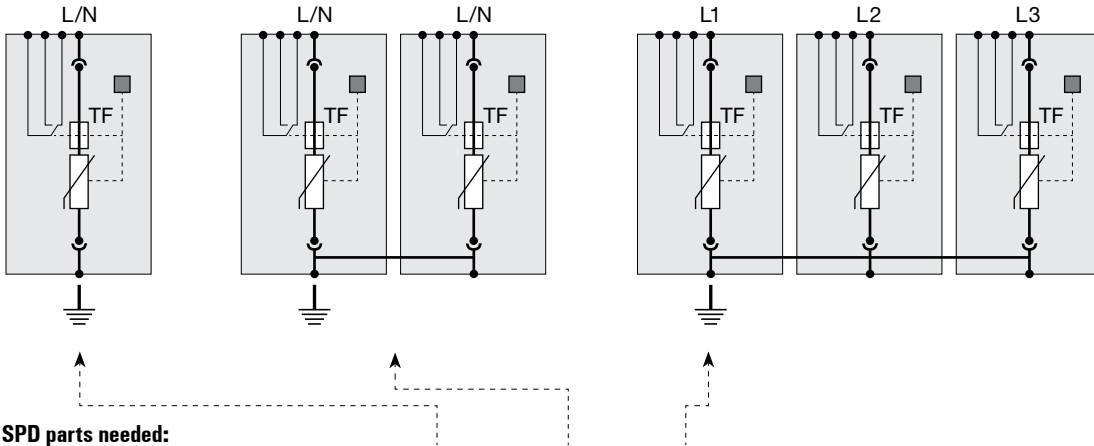

SPD parts needed:

Nom. V	Description	Qty	Qty	Qty	Part No.
110/120V	SPD II 120V/40kA	1	2	3	6720005410
230/240V	SPD II 230V 40kA	1	2	3	6720005411
277V	SPD II 277V 40kA	1	2	3	6720005412
480V	SPD II 480V 40kA	1	2	3	6720005413
All	SPD 2P Link	0	1	0	6720005417
All	SPD 3P Link	0	0	1	6720005418

Basic configurations 2

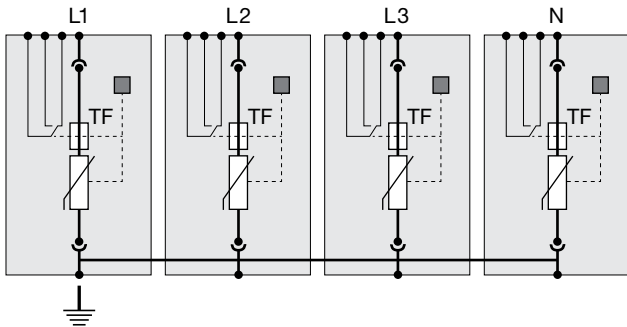

SPD parts needed:

Nom. V	Description	Qty	Part No.
110/120V	SPD II 120V/40kA	4	6720005410
230/240V	SPD II 230V 40kA	4	6720005411
277V	SPD II 277V 40kA	4	6720005412
480V	SPD II 480V 40kA	4	6720005413
All	SPD 4P Link	1	6720005419

Basic configurations 3

TT network
Nom: 120V

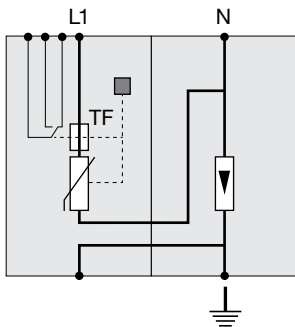

SPD parts needed:

Nom. V	Description	Qty	Part No.
120V	SPD II 120V/G/40kA	1	6720005415

TT network

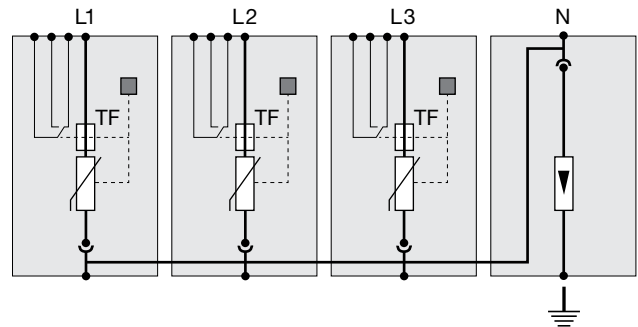

SPD parts needed:

Nom. V	Description	Qty	Part No.
110/120V	SPD II 120V/40kA	3	6720005410
230/240V	SPD II 230V 40kA	3	6720005411
277V	SPD II 277V 40kA	3	6720005412
480V	SPD II 480V 40kA	3	6720005413
All	SPD II N/PE	1	6720005414
All	SPD S Link 1/3	1	6720005461

VARITECTOR - Surge Protection for Control I/O Signals

Product quick selection for measurement and control signals

Instrumentation and control equipment

Interface/ signal	Mounting	Connection system	Protected wires	Discharge	Operating	max.	Protection device	Part No. Arrestor	Part No. Direct earthing base	Part No. Indirect earthing base
				capacity	current	voltage				
				8/20 μ s	I _{max} .	DC				
0(4) ... 20 mA	on DIN-rail, separable	Screw terminals	4	5 kA	0.45 A	28 V	VSPC 2CL 24 V DC 0.5 A	8924470000	8924710000	8924270000
0(4) ... 20 mA	on DIN-rail, separable	Screw terminals	2	5 kA	0.45 A	28 V	VSPC 1CL 24 V DC 0.5 A	8924480000	8924730000	8924290000
0...10 V	on DIN-rail, separable	Screw terminals	4	5 kA	0.45 A	28 V	VSPC 2CL 24 V DC 0.5 A	8924470000	8924710000	8924270000
0...10 V	on DIN-rail, separable	Screw terminals	2	5 kA	0.45 A	28 V	VSPC 1CL 24 V DC 0.5 A	8924480000	8924730000	8924290000
0-20 mA, 4-20 mA	on DIN-rail, compact	Tension clamp terminals	2	5 kA	0.5 A - 1.25 A	28 V	MCZ OVP 1CL 24 V 0.5 A	8448920000 8449080000		
VSSC and VSPC for binary signals	on DIN-rail, compact	Screw terminals	2	5 kA	0.5 A					
Hart	on DIN-rail, separable	Screw terminals	2	5 kA	0.45 A	28 V	VSPC 1CL 24 V DC 0.5 A	8924480000	8924730000	8924290000
Cathodic corrosion protection	on DIN-rail, separable	Screw terminals	2	5 kA	2 A	72 V	VSPC GDT 2 CH 90 V 20 kA	8924570000	8924740000	8924300000
PT 100, PT 1000	on DIN-rail, compact	Tension clamp terminals	2	5 kA	1.25 A	24 V	MCZ OVP SL 24 V 1.25 A	8448970000		
PT 100	on DIN-rail, binary	Screw terminals	4	5 kA	0.45 A	24 V	VSPC 3/4WIRE 24 V DC	8924550000	8924740000	8924300000
RS232	on DIN-rail, compact	Tension clamp terminals	2	5 kA	0.5 A	24 V	MCZ OVP SL 24 V 0.5 A	8448940000		
RS422,V11	on DIN-rail, compact	Tension clamp terminals	2	5 kA	0.5 A	24 V	MCZ OVP SL 24 V 0.5 A	8448940000		
RS422A, V.11, X.27, RS423A	on DIN-rail, separable	Screw terminals	4	5 kA	0.45 A	15 V	VSPC 2CL HF 12 V DC	8924460000	8924710000	8924270000
RS449	on DIN-rail, separable	Screw terminals	4	5 kA	0.45 A	15 V	VSPC 2CL HF 12 V DC	8924460000	8924710000	8924270000
RS485	on DIN-rail, compact	Tension clamp terminals	2	5 kA	0.5 A	24 V	MCZ OVP SL 24 V 0.5 A	8448940000		
RS485	built-in housing	Screw terminals	4	0.5 kA		12 V	RS485/RS422 K21	8008501001		
RS485	on DIN-rail, separable	Screw terminals	4	5 kA	0.45 A	6.4 V	VSPC R485 2 CH	8924670000	8924710000	8924270000
RS232-C / V.24	on DIN-rail, separable	Screw terminals	4	5 kA	0.45 A	15 V	VSPC 2CL HF 12 V DC	8924460000	8924710000	8924270000
TTL	on DIN-rail, compact	Tension clamp terminals	2	5 kA	0.5 A	24 V	MCZ OVP SL 24 V 0.5 A	8448940000		
TTY	on DIN-rail, compact	Tension clamp terminals	2	5 kA	0.5 A	24 V	MCZ OVP SL 24 V 0.5 A	8448940000		

Bus systems

Interface/ signal	Mounting	Connection system	Protected wires	Discharge	Operating	max.	Protection device	Part No. Arrestor	Part No. Direct earthing base	Part No. Indirect earthing base
				capacity	current	voltage				
				8/20 μ s	I _{max} .	DC				
ARCNET (Plus)	on DIN-rail	Screw terminals	2	2 kA	16 A	-	PU III R 48 V	8860350000		
ASI	on DIN-rail	Screw terminals	2	2 kA	16 A	-	PU III R 24 V	8860360000		
ASI	on DIN-rail, separable	Screw terminals	4	5 kA	0.45 A	15 V	VSPC 2CL HF 12 V DC	8924460000	8924710000	8924270000
BITBUS	on DIN-rail, separable	Screw terminals	4	5 kA	0.45 A	15 V	VSPC 2CL HF 12 V DC	8924460000	8924710000	8924270000
BLN (Building Level Network)	on DIN-rail, separable	Screw terminals	2	5 kA	0.45 A	28 V	VSPC 1CL 24 V DC 0.5 A	8924480000	8924730000	8924290000
BLN (Building Level Network)	on DIN-rail, separable	Screw terminals	4	5 kA	0.45 A	28 V	VSPC 2CL HF 12 V DC	8924460000	8924710000	8924270000
CAN-Bus	on DIN-rail, separable	Screw terminals	4	5 kA	0.45 A	15 V	VSPC 2CL HF 12 V DC	8924460000	8924710000	8924270000
CANopen	on DIN-rail, compact	Tension clamp terminals	2	5 kA	0.3 A	12 V	MCZ OVP HF 12 V 0.3 A	8948610000		
C-BUS	on DIN-rail, separable	Screw terminals	4	5 kA	0.45 A	15 V	VSPC 2CL HF 12 V DC	8924460000	8924710000	8924270000
C-Bus (Honeywell)	on DIN-rail, compact	Tension clamp terminals	2	5 kA	0.3 A	5 V	MCZ OVP HF 5 V 0.3 A	8948620000		
CC-LINK	on DIN-rail, separable	Screw terminals	4	5 kA	0.45 A	15 V	VSPC 2CL HF 12 V DC	8924460000	8924710000	8924270000
Data Highway (Plus), DH+	on DIN-rail, separable	Screw terminals	4	5 kA	0.45 A	15 V	VSPC 2CL HF 12 V DC	8924460000	8924710000	8924270000
DATEX P	on DIN-rail, compact	Tension clamp terminals	2	5 kA	0.3 A	24 V	MCZ OVP HF 24 V 0.3 A	8948600000		
Device Net	on DIN-rail, compact	Tension clamp terminals	2	5 kA	0.3 A	12 V	MCZ OVP HF 12 V 0.3 A	8948610000		
DeviceNet	on DIN-rail, separable	Screw terminals	4	5 kA	0.45 A	15 V	VSPC 2CL HF 12 V DC	8924460000	8924710000	8924270000
DIN measurement bus	on DIN-rail, separable	Screw terminals	2	5 kA	0.45 A	15 V	VSPC 1CL 12 V DC 0.5 A	8924450000	8924730000	8924290000
Dupline / Miniplex	on DIN-rail, separable	Screw terminals	2	5 kA	0.45 A	28 V	VSPC 1CL 24 V DC 0.5 A	8924480000	8924730000	8924290000

Bus systems

Interface/ signal	Mounting	Connection system	Protected wires	Discharge	Operating	max.	Protection device	Part No. Arrestor	Part No. Direct earthing base	Part No. Indirect earthing base
				capacity	current	voltage				
				8/20 µs	I _{max} .	DC				
E1	on DIN-rail, separable	Screw terminals	4	5 kA	0.45 A	6.4 V	VSPC 2CL HF 5 V DC	8924430000	8924710000	8924270000
EIB (European Installation Bus)	on DIN-rail, separable	Screw terminals	2	5 kA	0.45 A	28 V	VSPC 1CL 24 V DC 0.5 A	8924480000	8924730000	8924290000
ET 200	on DIN-rail, separable	Screw terminals	2	5 kA	0.45 A	28 V	VSPC 1CL 5 V DC 0.5 A	8924420000	8924730000	8924290000
ET 200	on DIN-rail, compact	Tension clamp terminals	2	5 kA	0.3 A	5 V	MCZ OVP HF 5 V 0.3 A	8948620000		
Ethernet Cat.6	Plug-in adapter	RJ 45 connection	4	10 kA	1 A	48 V	V DATA Cat.6	1348590000		
Ethernet Cat.5	Adapter plug	M12	4	10 kA		30 V	JACKPAC® Ethernet Cat.5 M12	8805570000		
Ethernet Cat.6	Adapter plug	RJ 45 connection	4	10 kA		48 V	JACKPAC® Ethernet Cat.6 IP20	8805550000		
Ethernet Cat.6	Adapter plug	RJ 45 connection	4	10 kA		48 V	JACKPAC® Ethernet Cat.6 IP67	8805560000		
FIPIO / FIPWAY	on DIN-rail, separable	Screw terminals	4	5 kA	0.45 A	6.4 V	VSPC 2CL HF 5 V DC	8924430000	8924710000	8924270000
Genius I/O Bus	on DIN-rail, separable	Screw terminals	4	5 kA	0.45 A	15 V	VSPC 2CL 12 V DC 0.5 A	8924440000	8924710000	8924270000
HDSL	on DIN-rail, compact	Tension clamp terminals	2	5 kA	0.3 A	24 V	MCZ OVP HF 24 V 0.3 A	8948600000		
IEC-BUS	on DIN-rail, separable	Screw terminals	4	5 kA	0.45 A	6.4 V	VSPC 2CL HF 5 V DC	8924430000	8924710000	8924270000
Interbus	on DIN-rail, compact	Tension clamp terminals	2	5 kA	0.3 A	5 V	MCZ OVP HF 5 V 0.3 A	8948620000		
Interbus-Inline I/O	on DIN-rail, compact	Tension clamp terminals	2	10 kA	1.25 A	53 V	MCZ OVP CL 48 V 1.25 A	8449040000		
LON™ (Works)	on DIN-rail, separable	Screw terminals	4	5 kA	0.45 A	85 V	VSPC 1CL 48 V AC 0.5 A	8924520000	8924730000	8924290000
LON™ TP/XF 78	on DIN-rail, compact	Tension clamp terminals	2	10 kA	0.5 A	28 V	MCZ OVP CL 24 V 0.5 A	8448920000		
LON™ TP/XF 78	on DIN-rail, compact	Tension clamp terminals	2	0,1 kA	16 A	14 V	MCZ OVP LON Bus	8473470000		
LON™-Bus	on DIN-rail, compact	Tension clamp terminals	2	5 kA	0.3 A	12 V	MCZ OVP HF 12 V 0.3 A	8948610000		
LRE networks	on DIN-rail, separable	Screw terminals	4	5 kA	0.45 A	6.4 V	VSPC 2CL HF 5 V DC	8924430000	8924710000	8924270000
LUXMATE-Bus	on DIN-rail, separable	Screw terminals	4	5 kA	0.45 A	28 V	VSPC 2CL HF 24 V DC	8924510000	8924710000	8924270000
M-Bus	on DIN-rail, compact	Tension clamp terminals	2	5 kA	0.3 A	24 V	MCZ OVP HF 24 V 0.3 A	8948600000		
M-Bus (remote reading of meter)	on DIN-rail, separable	Screw terminals	2	5 kA	0.45 A	28 V	VSPC 1CL 24 V AC 0.5 A	8924500000	8924730000	8924290000
MOD-Bus	on DIN-rail, compact	Tension clamp terminals	2	5 kA	0.3 A	5 V	MCZ OVP HF 5 V 0.3 A	8948620000		
MODBUS(-PLUS)	on DIN-rail, separable	Screw terminals	4	5 kA	0.45 A	15 V	VSPC 2CL HF 12 V DC	8924460000	8924710000	8924270000
MPI Bus	on DIN-rail, separable	Screw terminals	4	5 kA	0.45 A	6.4 V	VSPC R485 2 CH	8924670000	8924710000	8924270000
N1 LAN	on DIN-rail, separable	Screw terminals	4	5 kA	0.45 A	6.4 V	VSPC 2CL HF 5 V DC	8924430000	8924710000	8924270000
N2 Bus	on DIN-rail, separable	Screw terminals	2	5 kA	0.45 A	6.4 V	VSPC 2SL 5 V DC 0.5 A	8924210000	8924720000	8924280000
(P-Bus)	on DIN-rail, compact	Screw terminals	2	2 kA	16 A	-	PU III R 24 V	8860360000		
P-NET	on DIN-rail, separable	Screw terminals	4	5 kA	0.45 A	15 V	VSPC 2CL HF 12 V DC	8924460000	8924710000	8924270000
Procontic CS31	on DIN-rail, separable	Screw terminals	2	5 kA	0.45 A	15 V	VSPC 1CL 12 V DC 0.5 A	8924450000	8924730000	8924290000
Procontic CS31	on DIN-rail, separable	Screw terminals	4	5 kA	0.45 A	15 V	VSPC 2CL HF 12 V DC	8924460000	8924710000	8924270000
Procontic T200	on DIN-rail, separable	Screw terminals	4	5 kA	0.45 A	15 V	VSPC 2CL HF 12 V DC	8924460000	8924710000	8924270000
Profibus	on DIN-rail, compact	Tension clamp terminals	2	5 kA	0.3 A	5 V	MCZ OVP HF 5 V 0.3 A	8948620000		
(Profibus DP)	on DIN-rail, separable	Screw terminals	4	5 kA	0.45 A	6.4 V	VSPC R485 2 CH	8924670000	8924710000	8924270000
Profibus DP (FMS)	on DIN-rail, separable	Screw terminals	4	5 kA	0.45 A	6.4 V	VSPC 2CL HF 5 V DC	8924430000	8924710000	8924270000
Profibus DP (FMS)	on DIN-rail, separable	Screw terminals	4	5 kA	0.45 A	15 V	VSPC 2CL HF 12 V DC	8924460000	8924710000	8924270000
Profibus DP/FMS	on DIN-rail, separable	Screw terminals	2	6 kA	1.5 A	12 V	RS485	9454930000+8007871001		
Profibus PA	on DIN-rail, compact	Tension clamp terminals	2	10 kA	1.25 A	53 V	MCZ OVP CL 48 V 1.25 A	8449040000		
Profinet	on DIN-rail, compact	Tension clamp terminals	2	5 kA	0.3 A	5 V	MCZ OVP HF 5 V 0.3 A	8948620000		
Process Bus, Panel Bus	on DIN-rail, separable	Screw terminals	4	5 kA	0.45 A	15 V	VSPC 2CL HF 12 V DC	8924460000	8924710000	8924270000
PSM-EG-RS422...	on DIN-rail, separable	Screw terminals	4	5 kA	0.45 A	15 V	VSPC 2CL HF 12 V DC	8924460000	8924710000	8924270000
PSM-EG-RS485...	on DIN-rail, separable	Screw terminals	4	5 kA	0.45 A	15 V	VSPC 2CL HF 12 V DC	8924460000	8924710000	8924270000
RACKBUS	on DIN-rail, separable	Screw terminals	4	5 kA	0.45 A	6.4 V	VSPC 2CL HF 5 V DC	8924430000	8924710000	8924270000
SDLC	on DIN-rail, separable	Screw terminals	4	5 kA	0.45 A	15 V	VSPC 2CL HF 12 V DC	8924460000	8924710000	8924270000
SDSL	on DIN-rail, separable	Screw terminals	4	5 kA	0.45 A	185 V	VSPC Uko	8924660000	8924710000	8924270000
SecuriLan-LON™-Bus	on DIN-rail, separable	Screw terminals	2	5 kA	0.45 A	15 V	VSPC 1CL 12 V DC 0.5 A	8924450000	8924730000	8924290000
SINEC L1	on DIN-rail, separable	Screw terminals	4	5 kA	0.45 A	6.4 V	VSPC 2CL HF 5 V DC	8924430000	8924710000	8924270000
Sinec L2	on DIN-rail, compact	Tension clamp terminals	2	5 kA	0.3 A	5 V	MCZ OVP HF 5 V 0.3 A	8948620000		
SINEC L2 DP	on DIN-rail, separable	Screw terminals	4	5 kA	0.45 A	6.4 V	VSPC 2CL HF 5 V DC	8924430000	8924710000	8924270000
Sinec L2 DP/ -Profibus DP	on DIN-rail, separable	Screw terminals	2	6 kA	1.5 A	12 V	RS485	9454930000+8007871001		
TCP / IP	on DIN-rail, compact	Tension clamp terminals	2	5 kA	0.3 A	5 V	MCZ OVP HF 5 V 0.3 A	8948620000		
Token Ring	on DIN-rail, compact	Tension clamp terminals	2	0.5 kA	16 A	27 V	MCZ OVP TAZ 24 V	8449160000		
Token Ring	on DIN-rail, compact	Tension clamp terminals	2	5 kA	0.3 A	5 V	MCZ OVP HF 5 V 0.3 A	8948620000		
TP/FTT 10+TP/LPT10	on DIN-rail, compact	Tension clamp terminals	2	10 kA	1.25 A	53 V	MCZ OVP CL 48 V 1.25 A	8449040000		
U-BUS	on DIN-rail, separable	Screw terminals	4	5 kA	2 A	72 V	VSPC GDT 2 CH 90 V 20 kA	8924570000	8924740000	8924300000

Product quick selection, information technology

Telecommunications

Interface/ signal	Mounting	Connection system	Protected wires	Discharge	Operating	max.	Protection device	Part No. Arrestor	Part No. Direct earthing base	Part No. Indirect earthing base
				capacity	current	voltage				
				8/20 μ s	I _{max}	DC				
ADSL	on DIN-rail, separable	Screw terminals	4	5 kA	0.45 A	185 V	VSPC Uko	8924660000	8924710000	8924270000
ADVANT	on DIN-rail, separable	Screw terminals	4	5 kA	0.45 A	6.4 V	VSPC 2CL HF 5 V DC	8924430000	8924710000	8924270000
HDSL	on DIN-rail, separable	Screw terminals	4	5 kA	0.45 A	185 V	VSPC Uko	8924660000	8924710000	8924270000
SHDSL	on DIN-rail, separable	Screw terminals	4	5 kA	0.45 A	185 V	VSPC Uko	8924660000	8924710000	8924270000
T-DSL	on DIN-rail, separable	Screw terminals	4	5 kA	0.45 A	185 V	VSPC Uko	8924660000	8924710000	8924270000
Telephone analog	on DIN-rail, separable	Screw terminals	4	5 kA	0.45 A	185 V	VSPC Uko	8924660000	8924710000	8924270000
TTY, 0(4) - 20 mA	on DIN-rail, separable	Screw terminals	4	5 kA	0.45 A	28 V	VSPC 2CL 24 V DC 0.5 A	8924470000	8924710000	8924270000
(Uko-Bus)	on DIN-rail, separable	Screw terminals	4	5 kA	0.45 A	185 V	VSPC Uko	8924660000	8924710000	8924270000
V.35	on DIN-rail, separable	Screw terminals	4	5 kA	0.45 A	6.4 V	VSPC 2CL HF 5 V DC	8924430000	8924710000	8924270000
VDSL	on DIN-rail, separable	Screw terminals	4	5 kA	0.45 A	185 V	VSPC Uko	8924660000	8924710000	8924270000
X.21/X.24	on DIN-rail, separable	Screw terminals	4	5 kA	0.45 A	15 V	VSPC 2CL HF 12 V DC	8924460000	8924710000	8924270000
X.25/X.31	on DIN-rail, separable	Screw terminals	4	5 kA	0.45 A	15 V	VSPC 2CL HF 12 V DC	8924460000	8924710000	8924270000



SIL certification for VSSC and VSPC



Zertifikat

Certificate

Registrier-Nr.
Registration No.
44 799 11 394001-001

Zeichen des Auftraggebers Customer's reference	Auftragsdatum Date of order 16.03.2011	Aktenzzeichen File reference 8000394001	Technischer Bericht Nr. Test report no. 11 799 384001-001
Name und Anschrift des Auftraggebers Customer's name and address	Weidmüller Interface GmbH & Co. KG Klingenbergstraße 16 32758 Detmold		
Geprüft nach Tested in accordance with	EN 61508:2010 Funktionale Sicherheit sicherheitsbezogener elektrischer/elektronischer/programmierbarer elektronischer Systeme		
Beschreibung des Produktes (Details siehe Anlage 1) Description of product (Details see Annex 1)	Überspannungsschutz / Overvoltage protection		
Typenbezeichnung Type Description	VARITECTOR SPC und SSC		
Bemerkung Remark	Die einzelnen Typen der Überspannungsschutzserie können in SIL2 oder SIL3 Sicherheitskreisen eingesetzt werden! The single types of the overvoltage protection series can be used in SIL2 or SIL3 safety circuits. Die sichere Funktion bezieht sich auf den Einsatz in einem Kommunikationspfad! The safety function is intended for application in a communication path.		

Dieses Zertifikat bescheinigt das Ergebnis der Prüfung an dem vorgestellten Prüfgegenstand. Eine allgemein gültige Aussage über die Qualität der Produkte aus der laufenden Fertigung kann hieraus nicht abgeleitet werden.
This certifies the result of the examination of the product sample submitted by the manufacturer. A general statement concerning the quality of the products from the series manufacture cannot be derived therefrom.

TÜV NORD CERT GmbH
Zertifizierungsstelle / Certification body
Maschinen / Machinery
Hannover, 13.04.2011

Gültig bis / Valid to: 12.04.2016

Bitte beachten sie auch die umseitigen Hinweise
Please also pay attention to the information stated overleaf

Langermarkstr. 20 • 45141 Essen • Fon +49 (0)201 825 5120 • Fax +49 (0)201 825 3208 • Email: probstat@tuev-nord.de



Anlage 1 zum Zertifikat Nr.:

Annex 1 to Certificate no.

44 799 11 394001-001

Rev. 1

Aktenzzeichen: 8000394001
File reference

Seite 1 von 2
Page 1 of 2

Allgemeine Angaben
General information

Siehe Seite 1 des Zertifikates
See also page 1 of the Certificate

Typenbezeichnung
Type Description

VARITECTOR SPC und VARITECTOR SSC

Übersicht Parameter VARITECTOR SSC / Overview Parameter VARITECTOR SSC

Type	safe detected Avg. in 1·10 ⁶ [1/h]	safe undetected Avg. in 1·10 ⁶ [1/h]	dangerous detected Avg. in 1·10 ⁶ [1/h]	dangerous undetected Avg. in 1·10 ⁶ [1/h]	SFF	PFH in 1·10 ⁹ [1/a]	Max. SIL
VSSC4 CL	6,1	10,96	0	1,95	89,74%	1,95	2
VSSC4 CL FG	7,1	19,95	0	1,95	93,28%	1,95	3
VSSC4 SL	7	35,1	0	0,9	97,91%	0,9	3
VSSC4 SL FG	7	35,1	0	0,9	97,91%	0,9	3
VSSC4 MOV	2,5	22,75	0,75	0	100,00%	0	3
VSSC4 GDY	1	9	0	0	100,00%	0	3
VSSC4 TAZ	2,5	24,25	5,25	0	100,00%	0	3
VSSC4 RC	2,5	24,13	0,75	0,8	97,76%	0,8	3
VSSC6 CL	6,1	10,96	0	1,95	89,74%	1,95	2
VSSC6 CL FG	7,1	19,95	0	1,95	93,28%	1,95	3
VSSC6 TR CL	6,1	10,96	0	1,95	89,74%	1,95	2
VSSC6 TR CL FG	7,1	19,95	0	1,95	93,28%	1,95	3
VSSC6 SL	7	45,2	0	1,8	96,67%	1,8	3
VSSC6 SL FG	7	45,2	0	1,8	96,67%	1,8	3
VSSC6 TR SL	7	45,2	0	1,8	96,67%	1,8	3
VSSC6 TR SL FG	7	45,2	0	1,8	96,67%	1,8	3
VSSC6 MOV	2,5	22,75	0,75	0	100,00%	0	3
VSSC6 GDY	1	9	0	0	100,00%	0	3
VSSC6 TAZ	2,5	24,25	5,25	0	100,00%	0	3
VSSC6 TR MOV	2,5	32,85	0,75	0,9	97,51%	0,9	3
VSSC6 TR GDY	1	9	0	0	100,00%	0	3
VSSC6 TR TAZ	2,5	34,35	5,25	0,9	97,91%	0,9	3
VSSC6 RS485/VSSC6 RS485 DP	8	43,75	5	3,25	94,58%	3,25	3
VSSC6 RS232	13	57,5	2	3,5	95,36%	3,5	3
VSSC6 RS485 PA	5,5	19,75	2	1,75	93,97%	1,75	3
VSSC6 RTD	8	44,25	7	3,75	94,05%	3,75	3
VSSC6 RTD EX	8	43,75	6	3,25	94,67%	3,25	3



Anlage 1 zum Zertifikat Nr.:

Annex 1 to Certificate no.

44 799 11 394001-001

Rev. 1

Aktenzzeichen: 8000394001
File reference

Seite 2 von 2
Page 2 of 2

Übersicht Parameter VARITECTOR SPC / Overview Parameter VARITECTOR SPC

Type	safe detected Avg. in 1·10 ⁶ [1/h]	safe undetected Avg. in 1·10 ⁶ [1/h]	dangerous detected Avg. in 1·10 ⁶ [1/h]	dangerous undetected Avg. in 1·10 ⁶ [1/h]	SFF	PFH in 1·10 ⁹ [1/a]	Max. SIL
VSPC CL	13,8	29,45	0	1,95	95,67%	1,95	3
VSPC CL R	17,1	67,4	0	3,7	95,27%	3,70	3
VSPC CL HF	15,6	30,45	0	2,95	93,96%	2,95	3
VSPC CL HF R	19,1	58,4	0	4,7	94,26%	4,70	3
VSPC SL	6	27,1	1	8,9	79,30%	8,90	2
VSPC SL R	9,5	55,05	1	10,85	86,02%	10,7	2
VSPC 3/4 WIRE	36	107	0	7	95,33%	7,00	3
VSPC RS485	12	31,75	9	4,25	92,64%	4,25	3
VSPC RS485 R	15,5	59,7	9	6	93,30%	6,00	3
VSPC TELE UNO	15,6	30,45	0	2,95	93,96%	2,95	3
VSPC 1CL FW	13,8	29,45	0	1,95	95,67%	1,95	3
VSPC GDY ZCH	6	5	0	0	100,00%	0,00	3
VSPC MOV ZCH	2,5	22,75	0,75	0	100,00%	0,00	3
VSPC MOV ZCH R	2,5	73,95	0,75	0	100,00%	0,00	3
VSPC TAZ ZCH	2,5	24,25	5,25	0	100,00%	0,00	3
VSPC TAZ 4CH	2,5	24,25	5,25	0	100,00%	0,00	3

TÜV NORD CERT GmbH
Zertifizierungsstelle / Certification body
Maschinen / Machinery
Hannover, 13.04.2011

Gültig bis / Valid to: 12.04.2016

Bitte beachten sie auch die umseitigen Hinweise
Please also pay attention to the information stated overleaf

Langermarkstr. 20 • 45141 Essen • Fon +49 (0)201 825 5120 • Fax +49 (0)201 825 3208 • Email: probstat@tuev-nord.de



Lightning and surge protection for control and instrumentation signals

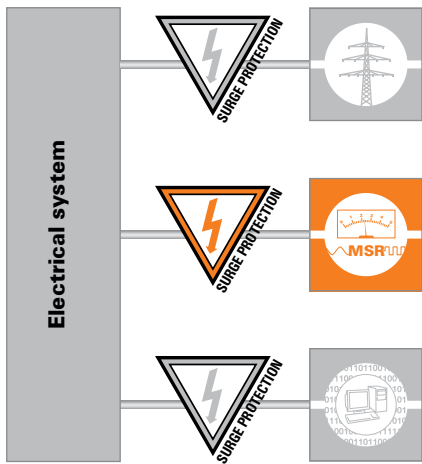

breakdowns or malfunctions can lead to exorbitant costs. As the standards covering low control voltages do not specify many parameters, the use of surge protection, apart from lightning protection zoning concepts, has to be classified according to type of signal, application circuit and the anticipated interference voltage phenomena.

Types of interference voltage

Transient surges coupled into a system via one or more coupling mechanisms occur as normal- or common-mode interference. These are measured as longitudinal or transverse voltages and, depending on the circuit, designated as symmetrical or asymmetrical voltages. (For further information see the "Principles" chapter.)

Basic classification

The current scope of automation technology has resulted in a wide range of applications for surge protection in the field of instrumentation and control engineering. One important prerequisite is the consistent use of coordinated surge protection in all sections of the plant or building. In industry, instrumentation and control systems are important areas and

Types of signal

Binary signals SL [△] (symmetrical loop)

These are two-wire signals with a common reference potential which are required by, for example, by switches, PLC switch outputs, photoelectric barriers, position sensors, solenoid valves, warning lamps, PLC inputs, etc. Normally, these signals have a common reference potential that can be either connected or not connected to earth potential, depending on the type of protection. The coupled transient interference is primarily common-mode interference.

Analog signals CL [△] (current loop)

Measuring circuits are normally designed as two-wire current loops or voltage signals without a common reference potential, like the 0(4)...20 mA current loop. The coupled transient interference is primarily normal-mode interference. For temperature measurements with the PT100 measuring shunt in the three-wire version, the voltage drop at the shunt is measured via the third wire. This must be included in the system of protection. The PT100 measuring shunt is also available in a four-wire version in which the voltage drop at the shunt is measured via the two additional lines without additional line losses in the PT100 measuring circuit. The coupled transient normal-mode interference occurs between the various wires.

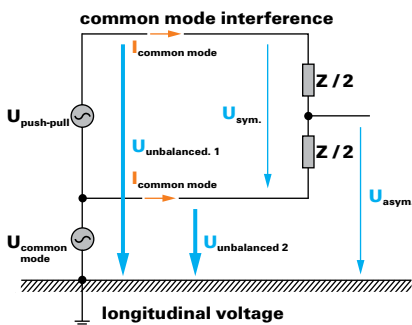

Common-mode interference (asymmetrical interference): Common-mode voltage between conductor and reference potential. (earth)/mainly caused by capacitive coupling (electrical field)

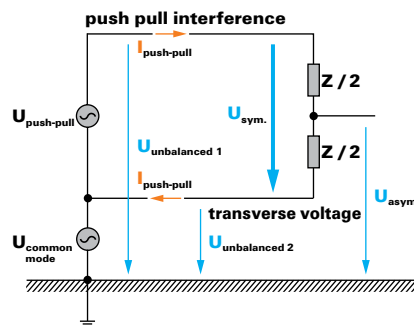

Normal-mode interference (symmetrical interference): Normal-mode voltage between supply and return conductor load and interference source connected in series, e.g. inductive (magnetic field) or conductive coupling (common impedance)

Essential information for users can be found in the IEC 61643-22 standard (application standard for measurement and control signals) and in the IEC 62305-4 standard (application standard for installing internal lightning protection). It is important to determine which protection category is required. There are divisions for D1 (lightning protection), C2 (surge protection / overvoltage protection) and C1 (end device protection). These categories or classes are specified for the following products. All products were subjected to a test in accordance with product standard IEC 61643-21:2008.

Binary signals

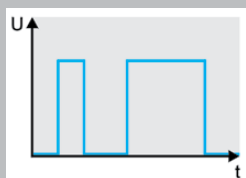

Two-wire, usually with common reference potential, e.g. signals from binary sensors, actuators and indicators such as limit switches, probes, position sensors, photoelectric barriers, contactors, solenoid valves, warning lamps.

Protection for binary signals connected to earth potential.

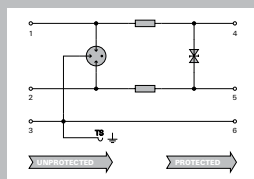

Protection for binary signals not connected to earth potential.

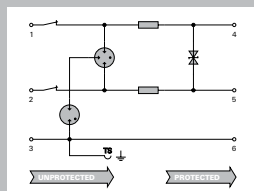

Protection for two-, three- and four-wire versions.

Type

VSPC 2SL	Page 84
VSPC 4SL	Page 88
VSPC 3/4	Page 92
VSPC GDT	Page 94
VSPC MOV	Page 96
VSPC TAZ	Page 98
VSPC UKO	Page 100
VSSC6 SL LD	Page 126
VSSC6 TR SL LD	Page 128
VSSC6 SLFG LD	Page 126
VSSC6 TR SLFG LD	Page 128
VSSC6 MOV	Page 130
VSSC6 TR MOV	Page 132
VSSC6 GDT	Page 134
VSSC6 TR GDT	Page 136
VSSC6 TAZ	Page 138
VSSC6 TR TAZ	Page 138
VSSC6 RTD	Page 142

Type

VSSC4 SL	Page 148
VSSC4 SL FG	Page 148
VSSC4 MOV	Page 150
VSSC4 GDT	Page 152
VSSC4 TAZ	Page 154
VSSC4 RC	Page 156

Analog signals

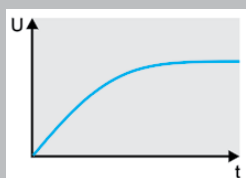

Two-, three- and four-wire versions without common reference potential.

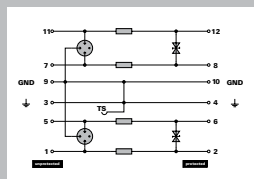

Signals from current loops (analog measurements from sensors over long distances), 4...20 mA, 0...20 mA, etc., e.g. level measurements.

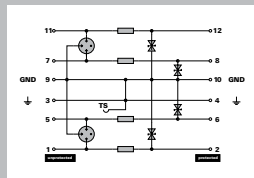

Signals from voltage sensors (analog measurements from sensors over short distances), 0...10 V, PT100, etc., e.g. temperature measurements.

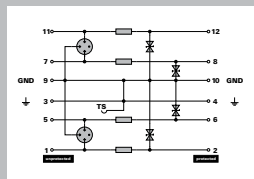

Type

VSPC 1CL	Page 74
VSPC 2CL	Page 78
VSPC 1CL PW	Page 82
VSPC RS485	Page 102
VSSC6 CL	Page 122
VSSC6 TR CL	Page 124
VSSC6 CLFG	Page 122
VSSC6 RS485	Page 140
VSSC6 RS485 DP	Page 141
VSSC6 RS232	Page 140
VSSC4 CL	Page 146
VSSC4 CL FG	Page 146

VARITECTOR SPC

Pluggable surge protection for the measurement and control industry VARITECTOR SPC

Weidmüller's VARITECTOR SPC pluggable surge protection is remarkable for its combination of extremely high protective functionality and compact dimensions. It is suited for use in measurement and control circuits. The size is made possible by the selection of INSTA dimensions, with a width of 17.8 mm (1TE).

Two versions are available:

- VSPC: a surge protector **with no** monitoring function
- VSPC R: a surge protector **with** monitoring function

The base components are plugged in to form a direct earthing contact via the mounting rail. This saves you time when making the connection. The VARITECTOR SPC series is optimally designed for compact installations in process automation, industrial automation and building automation. The two-stage surge-protection base components are equipped with gas discharge tubes, suppressor diodes (TVS) and decoupling components. Individual protective components (such as gas-filled spark gaps, varistors and suppressor diodes) supplement this product line. IEC 62305 requires that a periodic inspection of surge protection products be conducted. The functionality of all VARITECTOR SPC modules can be tested using testing equipment (such as the V-TEST Basic) that is available separately. The VARITECTOR SPC R modules also feature an internal monitoring function. The green LED signals when the protection function is ready. The red LED signals an error.

Up to ten modules can be wired together in succession. The modules alert an evaluative module (the VSPC CONTROL UNIT) in the event of an error. VARITECTOR SPC series surge protection is available with rated voltages of 5 V, 12 V, 24 V, 48 V and 60 V. The product's voltage level is color-coded on the pluggable arrester. An earthing contact is established by snapping onto an earthed TS 35 rail. The TS 35 must be earthed in order to ensure safe power discharging via the terminals of up to 20 kA (8/20 μ s) and 2.5 kA (10/350 μ s). The rail must be screwed onto the earthed mounting plate for reasons of EMC. In order to optimise the protective function, a PE-contact connection should be made over the VSPC module every 60 cm for equipotential bonding. The pluggable protective element can be pulled out during operations without interrupting the measurement circuit. A testing instrument, available as a Weidmüller accessory, allows you to test the protective element in compliance with the IEC 62305-3 directive. The accessory also includes a simple mechanism for applying the wire shield.



Overview of model types

A VARITECTOR SPC (VSPC) consists of a **pluggable component** and a separate **base component (VSPC BASE)**.

Explanation of terms:

CL = current loop / analog signals

SL = symmetric loop - for binary signals

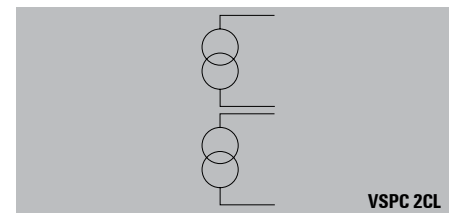
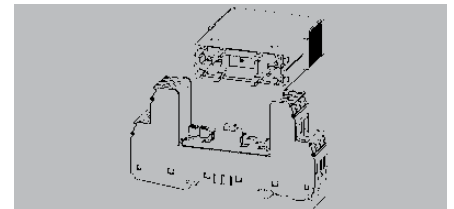

VSPC 2CL (CL = current loop) is a two-stage protective combination with a gas discharge tube and a suppressor diode located between the current paths. This VSPC 2CL limits the surge voltage within **two analog signal circuits** (such as for current loops). This pluggable component can be inserted into the base (VSPC BASE 2CL). The base (VSPC BASE FG 2CL) is used when working with signal circuits which are not earthed. The VSPC 2CL HF is used in order to avoid influencing high-frequency signal circuits (this also includes the VSPC RS485 and the VSPC UKO). This protective combination is also inserted into the base mentioned above.

Monitoring function

The **VSPC 2CL R** products feature monitor and alert functions. As well as the alert function, there are two channels available for current loops in a single housing. The special VSPC BASE 2CL R and SPC BASE 2CL FG R bases

transfer the alert function to a 2-pole screw/plug-in connection in the bases and to the VSPC CONTROL UNIT.

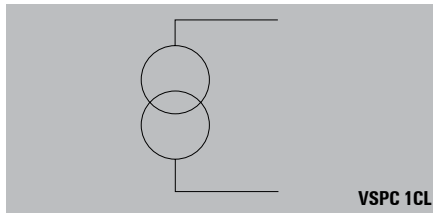

The **VSPC 1CL** is a two-stage protective combination with a gas discharge tube and a suppressor diode located between the current paths. This VSPC 1CL limits the surge voltage within **one analog signal circuit** (such as for current loops). This pluggable component can be inserted into the base (VSPC BASE 1CL). The base (VSPC BASE FG 1CL) is used when working with signal circuits which are not earthed.

Monitoring function

The **VSPC 1CL R** products feature monitor and alert functions. All channels remain despite the alert function. The special VSPC BASE 1CL R and VSPC BASE 1CL FG R bases transfer the alert function to a 2-pole screw/plug-in connection in the bases and to the VSPC CONTROL UNIT.

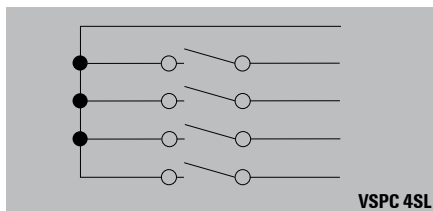

The **VSPC 4SL** is a two-stage protective combination with a gas discharge tube and a suppressor diode from the current path to the PE. This VSPC 4SL limits the surge voltage within **four binary signal circuits** (such as for alert contacts). This pluggable component can be inserted into the base (VSPC BASE 4SL). The base (VSPC BASE FG 4CL) is used

when working with signal circuits which are not earthed.

Monitoring function

The **VSPC 4SL R** products feature monitor and alert functions. Even with the alert function, there are still channels available for the four binary signal circuits in a single housing. The special VSPC BASE 4SL R base transfers the alert function to a 2-pole screw/plug-in connection in the base and to the VSPC CONTROL UNIT.

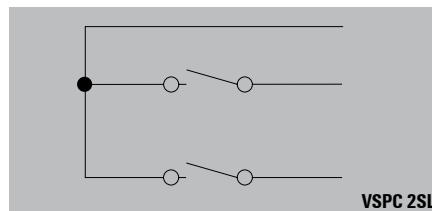

The **VSPC 2SL** is a two-stage protective combination with a gas discharge tube and a suppressor diode from the current path to the PE. This VSPC 2SL limits the surge voltage within **two binary signal circuits** (such as for alert contacts). This pluggable component can be inserted into the base (VSPC BASE 2SL). The base (VSPC BASE 2CL FG) is used when working with signal circuits which are not earthed.

Monitoring function

The VSPC 2SL R products feature monitor and alert functions. Even with the alert function, there are still channels available for the two binary signal circuits in a single housing. The special VSPC BASE 2SL R base transfers the alert function to a 2-pole screw/plug-in connection in the base and to the VSPC CONTROL UNIT.

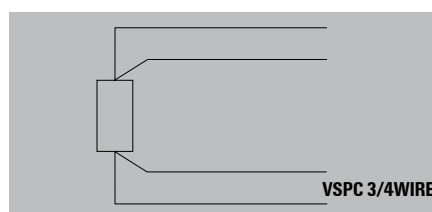

The **VSPC 3/4WIRE** is a two-stage protective combination with a gas discharge tube and a suppressor diode from the current path to the GND. This VSPC 3/4WIRE limits the surge voltage within four temperature-measurement circuits (such as for DMS or PT100/100 sensors). For non-earthed measurement circuits, we recommend using the base (VSPC BASE FG 4CL).

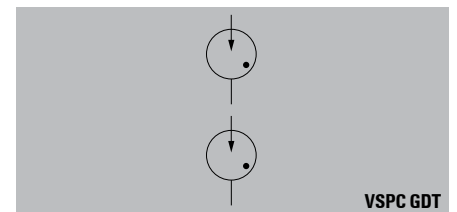

VSPC MOV 2CH, VSPC TAZ 2CH and VSPC GDT 2CH

Four cables can be protected with the 2CH modules. By wiring the connections differently, either two no-voltage signal lines or four binary signal lines can be protected. Two three-pole gas discharge tubes (GDTs) are used for the VSPC GDT 2CH. This universal protective circuitry limits the voltage between the signal lines and also between each signal line and the PE.

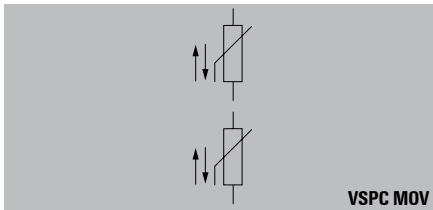
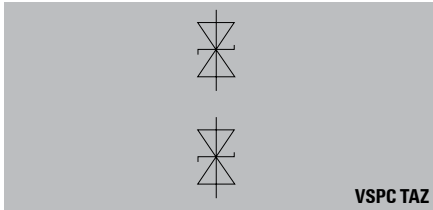

The **VSPC MOV 2CH** and **TAZ 2CH** offer one-stage protection with a varistor (MOV) or suppressor diode (TAZ or TVS) between the current paths. This makes it possible to protect a no-voltage (floating) signal circuit. Two binary signal circuits can also be protected if terminals 1 and 7 are assigned to GND / PE. These VSPC pluggable components are inserted into the base (VSPC BASE 2/4CH). The base (VSPC BASE 2/4CH FG) is used when working with signal circuits which are not earthed.

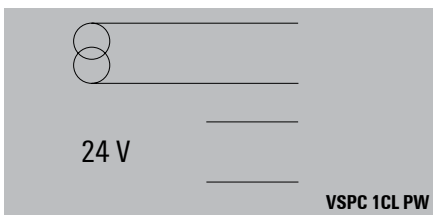

VSPC 1CL PW (power and signal 1CL) offers combined protection that is suitable for the 24 V DC power supply and the current loops within a device. This VSPC protects sensors with an additional 24 V DC.

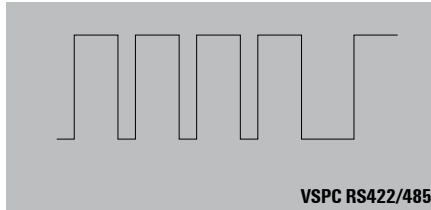

The **VSPC RS485** is a two-stage protective combination with a gas discharge tube and a suppressor diode located between the current paths. This VSPC RS485 limits the surge voltage within **two high-frequency signal circuits**. This pluggable component can be inserted into the base (VSPC BASE 2CL). The base (VSPC BASE FG 2CL) is used when working with signal circuits which are not earthed.

Monitoring function

The **VSPC RS485 R** product features monitoring and alert functions. Even with the alert function, there are still two channels available for current loops in a single housing. The special VSPC BASE 2CL R and VSPC BASE 2CL FG R bases transfer the alert function to a 2-pole screw/plug-in connection in the bases and to the VSPC CONTROL UNIT.

Earthing unit and test plug

The earthing unit can be used during installation to short out the connected wires to earth. The earthing unit is swapped out for a VSPC pluggable component before the initial commissioning. The test plug has 2.3-mm sockets. These sockets can be used by a meter to check the connected measurement circuit.

Applications

The pluggable INSTA housing was created in compliance with DIN 43880. It consists of a lower section (the VSPC BASE) and a pluggable component (the VSPC). The VSPC BASE is made from black PA6.6 V0. The pluggable component is made from red PA6.6 V0. The temperature range is from -40 °C to + 70 °C. The VSPC series has been tested to comply with IEC 61643-21 04/2008 and EN 61643-21. Modules were tested with categories C1, C2 and C3: with quick-rising edges with up to 300 pulses. Category D1 describes high power testing (10/350 µs lightning protection), so that the VSPC can be used according to IEC 62305-4. The base and pluggable components are color coded according to the voltage level. This makes installation easier.

Color coding

The pluggable components transfer their coding to the base element when they are plugged in for the first time. The voltage levels are also labelled with colored Dekafix markers applied to the VSPC pluggable component. This gives you a better overview within the electrical cabinet.

Voltage level	Color
≤ 12 V	green
24 V Binary	blue
24 V Analog	yellow
48 V	red
≥ 60 V	violet
Special function	white

Test possibility / V-TEST

Because the modules are pluggable, it is possible to test the VSPC visually or by using a V-TEST testing device. The VSPC can be easily tested; the user needs only to insert the VSPC pluggable component into the V-TEST. The result is then shown on the display. The VSPC R modules also feature an internal monitoring function for the arrester. An error is displayed at the defective module. The VSPC CONTROL UNIT can then transfer an alert to the control room.

Reoccurring tests / V-TEST

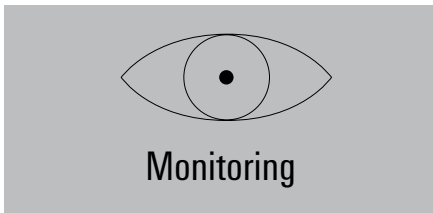

The IEC 62305-3 requires testing and maintenance for lightning protection systems. This includes the testing of the arresters used in the system.

Class of protection	Interval for complete testing	Interval for visual inspection
I	2 years	1 year
II	4 years	2 years
III/IV	6 years	3 years

Caution! These periodic inspections may be extended with stricter requirements pertaining to special applications or regions.

Remote error diagnostics

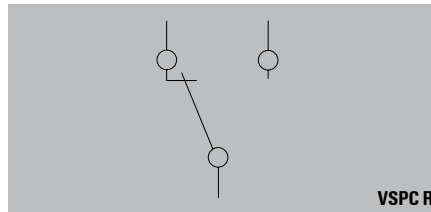

When the VSPC module labelled "R" is inserted into the corresponding "R" base component, it is then possible to use the outage alert function via a two-pole plug. This screw/plug-in connection has a clamping range from 0.5 to 1.5 mm².

The wire stripping length is 6 to 6.5 mm. A screwdriver with a 2-mm blade width is used to turn the screw. The VSPC Rs are connected in succession to the VSPC CONTROL UNIT evaluative module. Up to ten VSPC Rs can be connected in succession to the VSPC CONTROL UNIT. The evaluative module is supplied with 24 V DC. It is then responsible for the switching and for the voltage supply to the VSPC modules. A no-voltage (floating) CO contact can then be used to alert in the event of an outage. The error on the module, with the LED changing color from green to red. An automatic reset is carried out by the VSPC CONTROL UNIT within one minute after the failed VSPC pluggable component is replaced.

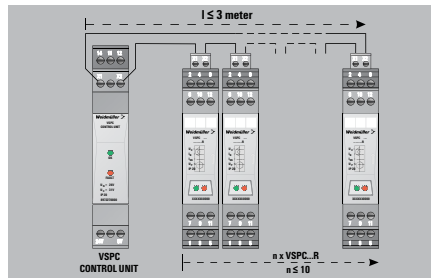

Installation

The VSPC series is appropriate for protecting signal circuits. In order to achieve a complete protective strategy for the facility, the power feed must be protected against Type II surge voltages (for example, by using our VPU II series). For existing lightning protection facilities, Type I protection must be used (for example, by using our VPU I series). Type II protection (for example, our VPU II) is sufficient when there is no lightning protection in place.

Fusing

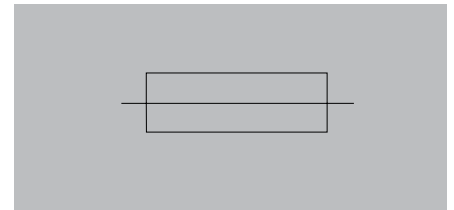

The VSPC surge protection modules are designed so that they are decoupled between the individual protective stages.

The following must be observed when providing fuse protection externally:

- Max. rated current
- Deratings curve
- Type of installation
- Application

Discharge capacity

Testing is conducted using voltage and current pulses according to the IEC 61643-21 standard concerning surge protection in networks which process signals.

Category	Testing pulse	Surge voltage	Surge current	Pulse	Type
C1	Quick rising edge	0.5-2 kV with 1.2/50 µs	0.25-1 kA with 8/20 µs	300	Surge voltage arrester
C2	Quick rising edge	2-10 kV with 1.2/50 µs	1-5 kA with 8/20 µs	10	Surge voltage arrester
C3	Quick rising edge	≥ 1 kV with 1 kV/µs	10-100 A with 10/10.000 µs	300	Surge voltage arrester
D1	High power	≥ 1 kV	0.5-2.5 kA with 10/350 µs	2	Arrester for lightning current and surge voltages

Category C reflects the interference pulses with quick-rising edges and minimised power. Category D uses quick-rising edges and high power to detail the interference pulses. This energy simulates the high-power load that stems from coupled partial lightning currents.

General technical data

Storage temperature -40 °C...+80 °C
 Operating temperature: -40 °C...+70 °C
 Air humidity 5%...96% RH with no condensation
 Material: V0, IP 20

Connection: screw connection
 screwdriver blade: 0.6 x 3.5 DIN 5264 (for example, 0.6x3.5x200, part no. 9010110000)
 rated torque: 0.5 Nm
 max. torque: 0.8 Nm
 stripping length: 7 mm
 solid: 0.5...4 mm²
 flexible: 0.5...2.5 mm²
 wire-end ferrule with plastic collar: 0.5...2.5 mm²

Remote signalling connection: screw connection
 screwdriver blade: 0.4 x 2.0 DIN 5264 (for example, SD 0.4x2.0x60, part no. 9037160000)
 max. torque: 0.2 Nm
 stripping length: 6...6.5 mm
 solid: 0.5...1.5 mm²

Dimensions

Height: 90 mm
 Height: with remote signalling contact: 98 mm
 Depth: 69 mm
 Width: 17.8 mm

Accessories

Markers

The VSPC BASE lower section can be labelled with Dekafix-5 markers. The VSPC pluggable modules are color coded with Dekafix-5 markers according to their rated voltage.

Shield connection

EMC SET, **part no. 1067470000**
 The EMC set consists of a connection component with shielding and a cable tie covered with shielding braid. The RT-1 cable tie tool (**part no. 1296000000**) can be used to fasten the cable ties professionally.



V-TEST

Testing device for functional tests of the pluggable VSPC, PU II and PU I surge protection.



VSPC Ground

This plug is attached to unused wires in the base element, so that all wires have the same potential.

VSPC TEST CONNECTOR

This plug-in component is used for measuring the signal circuits. Testing is very easy when using sockets 2.3.

VARITECTOR SPC – Choice of device depending on the interface

Interface	Pluggable arrester	Part No. Arrester	Part No. Base	Part No. Base floating ground (FG)	Pluggable arrester with operation message (R)	Part No. Arrester	Part No. Base	Part No. Base floating ground (FG)
0(4) ... 20 mA	VSPC 2CL 24 V DC 0.5 A	8924470000	8924710000	8924270000	VSPC 2CL 24 V DC 0.5 A R	8951480000	8951710000	8951720000
0(4) ... 20 mA	VSPC 1CL 24 V DC 0.5 A	8924480000	8924730000	8924290000	VSPC 1CL 12 V DC 0.5 A R	8951540000	8951730000	8951740000
0 ... 10 V	VSPC 2CL 24 V DC 0.5 A	8924470000	8924710000	8924270000	VSPC 2CL 24 V DC 0.5 A R	8951480000	8951710000	8951720000
0 ... 10 V	VSPC 1CL 24 V DC 0.5 A	8924480000	8924730000	8924290000	VSPC 1CL 12 V DC 0.5 A R	8951540000	8951730000	8951740000
ADSL	VSPC Uko	8924660000	8924710000	8924270000				
ADVANT	VSPC 2CL HF 5 V DC	8924430000	8924710000	8924270000	VSPC 2CL HF 5 V DC R	8951680000	8951710000	8951720000
ARCNET (Plus)	VSPC RS485 2ch	8924670000	8924710000	8924270000	VSPC RS485 2ch R	8951670000	8951710000	8951720000
ASI	PU III R 48 V DC	8860350000			PU III R 48 V DC	8860350000		
	PU III R 24 V DC	8860360000			PU III R 24 V DC	8860360000		
BITBUS	VSPC 2CL HF 12 V DC	8924460000	8924710000	8924270000	VSPC 2CL 12 V DC 0.5 A R	8951470000	8951710000	8951720000
BLN (Building Level Network)	VSPC 2CL HF 12 V DC	8924460000	8924710000	8924270000	VSPC 2CL 12 V DC 0.5 A R	8951470000	8951710000	8951720000
	VSPC 1CL 24 V DC 0.5 A	8924480000	8924730000	8924290000	VSPC 1CL 12 V DC 0.5 A R	8951540000	8951730000	8951740000
CAN-Bus	VSPC 2CL HF 12 V DC	8924460000	8924710000	8924270000	VSPC 2CL HF 12 V DC R	8951690000	8951710000	8951720000
C-BUS	VSPC 2CL HF 12 V DC	8924460000	8924710000	8924270000	VSPC 2CL HF 12 V DC R	8951690000	8951710000	8951720000
CC-LINK	VSPC 2CL HF 12 V DC	8924460000	8924710000	8924270000	VSPC 2CL HF 12 V DC R	8951690000	8951710000	8951720000
Data Highway (Plus), DH+	VSPC 2CL HF 12 V DC	8924460000	8924710000	8924270000	VSPC 2CL HF 12 V DC R	8951690000	8951710000	8951720000
Datex-P	VSPC 2CL HF 12 V DC	8924460000	8924710000	8924270000	VSPC 2CL HF 12 V DC R	8951690000	8951710000	8951720000
DeviceNet	VSPC 2CL HF 12 V DC	8924460000	8924710000	8924270000	VSPC 2CL HF 12 V DC R	8951690000	8951710000	8951720000
DIN measurement bus	VSPC 2CL HF 12 V DC	8924460000	8924710000	8924270000	VSPC 2CL HF 12 V DC R	8951690000	8951710000	8951720000
Dupline/Miniplex	VSPC 1CL 12 V DC 0.5 A	8924450000	8924730000	8924290000	VSPC 1CL 12 V DC 0.5 A R	8951540000	8951730000	8951740000
EIB (European Installation Bus)	VSPC 1CL 24 V DC 0.5 A	8924480000	8924730000	8924290000	VSPC 1CL 24 V DC 0.5 A R	8951550000	8951730000	8951740000
ET 200	VSPC 1CL 5 V DC 0.5 A	8924420000	8924730000	8924290000	VSPC 1CL 5 V DC 0.5 A R	8951530000	8951730000	8951740000
E1	VSPC Uko	8924660000	8924710000	8924270000				
	VSPC 2CL HF 5 V DC	8924430000	8924710000	8924270000	VSPC 2CL HF 5 V DC R	8951680000	8951710000	8951720000
FIPIO/FIPWAY	VSPC 2CL HF 5 V DC	8924430000	8924710000	8924270000	VSPC 2CL HF 5 V DC R	8951680000	8951710000	8951720000
Genius I/O Bus	VSPC 2CL 12 V DC 0.5 A	8924440000	8924710000	8924270000	VSPC 2CL 12 V DC 0.5 A R	8951470000	8951710000	8951720000
Hart	VSPC 1CL 24 V DC 0.5 A	8924480000	8924730000	8924290000	VSPC 1CL 24 V AC 0.5 A R	8951560000	8951730000	8951740000
HDSL	VSPC Uko	8924660000	8924710000	8924270000				
IEC-BUS	VSPC 2CL HF 5 V DC	8924430000	8924710000	8924270000	VSPC 2CL HF 5 V DC R	8951680000	8951710000	8951720000
ISDN Basic connection (Uko-Bus)	VSPC Uko	8924660000	8924710000	8924270000				
Cathodic corrosion prevention	VSPC GDT 2ch 90 V 20 kA	8924570000	8924740000	8924300000				
LON™ (Works)	VSPC 1CL 48 V AC 0.5 A	8924520000	8924730000	8924290000				
LRE networks	VSPC 2CL HF 5 V DC	8924430000	8924710000	8924270000	VSPC 2CL HF 5 V DC R	8951680000	8951710000	8951720000
LUXMATE-Bus	VSPC 2CL HF 24 V DC	8924510000	8924710000	8924270000	VSPC 2CL HF 24 V DC R	8951700000	8951710000	8951720000
M-Bus (Remote readout of counter)	VSPC 1CL 48 V AC 0.5 A	8924520000	8924730000	8924290000	VSPC 1CL 24 V DC 0.5 A R	8951550000	8951730000	8951740000
MODBUS-(PLUS)	VSPC 2CL HF 12 V DC	8924460000	8924710000	8924270000	VSPC 2CL HF 12 V DC R	8951690000	8951710000	8951720000
MPI-Bus	VSPC RS485 2ch	8924670000	8924710000	8924270000				
N1 LAN	VSPC 2CL HF 5 V DC	8924430000	8924710000	8924270000	VSPC 2CL HF 5 V DC R	8951680000	8951710000	8951720000
N2 Bus	VSPC 2SL 5 V DC 0.5 A	8924210000	8924720000	8924280000	VSPC 2SL 5 V DC 0.5 A R	8951610000	8951770000	8951780000
P-NET	VSPC 2CL HF 12 V DC	8924460000	8924710000	8924270000	VSPC 2CL HF 12 V DC R	8951690000	8951710000	8951720000
Procontic CS31	VSPC 1CL 12 V DC 0.5 A	8924450000	8924730000	8924290000	VSPC 1CL 12 V DC 0.5 A R	8951540000	8951730000	8951740000
	VSPC 2CL HF 12 V DC	8924460000	8924710000	8924270000	VSPC 2CL HF 12 V DC R	8951690000	8951710000	8951720000
Procontic T200	VSPC 2CL HF 12 V DC	8924460000	8924710000	8924270000	VSPC 2CL HF 12 V DC R	8951690000	8951710000	8951720000
Profibus DP (FMS)	VSPC 2CL HF 5 V DC	8924430000	8924710000	8924270000	VSPC 2CL HF 5 V DC R	8951680000	8951710000	8951720000
	VSPC 2CL HF 12 V DC	8924460000	8924710000	8924270000	VSPC 2CL HF 12 V DC R	8951690000	8951710000	8951720000
Process-Bus	VSPC 2CL HF 12 V DC	8924460000	8924710000	8924270000	VSPC 2CL HF 12 V DC R	8951690000	8951710000	8951720000
Panel-Bus								
PT100	VSPC 3/WIRE 24 V DC	8924550000	8924740000	8924300000				
P-Bus	PU III R 24 V DC	8860360000			PU III R 24 V DC	8860360000		
PSM-EG-RS422...	VSPC 2CL HF 12 V DC	8924460000	8924710000	8924270000	VSPC 2CL HF 12 V DC R	8951690000	8951710000	8951720000
PSM-EG-RS485...	VSPC 2CL HF 12 V DC	8924460000	8924710000	8924270000	VSPC 2CL HF 12 V DC R	8951690000	8951710000	8951720000
RACKBUS	VSPC 2CL HF 5 V DC	8924430000	8924710000	8924270000	VSPC 2CL HF 5 V DC R	8951680000	8951710000	8951720000
RS422A, V.11, X.27, RS423A	VSPC 2CL HF 12 V DC	8924460000	8924710000	8924270000	VSPC 2CL HF 12 V DC R	8951690000	8951710000	8951720000
RS449	VSPC 2CL HF 12 V DC	8924460000	8924710000	8924270000	VSPC 2CL HF 12 V DC R	8951690000	8951710000	8951720000
RS485	VSPC RS485 2ch	8924670000	8924710000	8924270000	VSPC RS485 2ch R	8951670000	8951710000	8951720000
RS232-C/V.24	VSPC 2CL HF 12 V DC	8924460000	8924710000	8924270000	VSPC 2CL HF 12 V DC R	8951690000	8951710000	8951720000
SDLC	VSPC 2CL HF 12 V DC	8924460000	8924710000	8924270000	VSPC 2CL HF 12 V DC R	8951690000	8951710000	8951720000
SDSL	VSPC Uko	8924660000	8924710000	8924270000				
SecurLan-LON™-Bus	VSPC 1CL 12 V DC 0.5 A	8924450000	8924730000	8924290000	VSPC 1CL 12 V DC 0.5 A R	8951540000	8951730000	8951740000
SHDSL	VSPC Uko	8924660000	8924710000	8924270000				
SINEC L1	VSPC 2CL HF 5 V DC	8924430000	8924710000	8924270000	VSPC 2CL HF 5 V DC R	8951680000	8951710000	8951720000
SINEC L2 DP	VSPC 2CL HF 5 V DC	8924430000	8924710000	8924270000	VSPC 2CL HF 5 V DC R	8951680000	8951710000	8951720000
Profibus DP	VSPC RS485 2ch	8924670000	8924710000	8924270000	VSPC RS485 2ch R	8951670000	8951710000	8951720000
T-DSL	VSPC Uko	8924660000	8924710000	8924270000				
Telephone analog	VSPC Uko	8924660000	8924710000	8924270000				
TTY, 0(4) - 20 mA	VSPC 2CL 24 V DC 0.5 A	8924470000	8924710000	8924270000	VSPC 2CL 24 V DC 0.5 A R	8951480000	8951710000	8951720000
U-BUS	VSPC GDT 2ch 90 V 20 kA	8924570000	8924740000	8924300000				
VDSL	VSPC Uko	8924660000	8924710000	8924270000				
V.35	VSPC 2CL HF 5 V DC	8924430000	8924710000	8924270000	VSPC 2CL HF 5 V DC R	8951680000	8951710000	8951720000
X.21/X.24	VSPC 2CL HF 12 V DC	8924460000	8924710000	8924270000	VSPC 2CL HF 12 V DC R	8951690000	8951710000	8951720000
X.25/X.31	VSPC 2CL HF 12 V DC	8924460000	8924710000	8924270000	VSPC 2CL HF 12 V DC R	8951690000	8951710000	8951720000

This table contains recommendations for the choice of device. Our technical consultants will be glad to assist you with your individual requirements.

VARIRECTOR SPC

Pluggable lightning and surge protection for measurement and control circuits

Pluggable lightning and surge protection for 2 analog signals or 4 binary signals in measurement/control circuits – with integrated error detection and alert functions in only 17.8 mm width.

Our pluggable VARIRECTOR SPC surge protection is characterised by highest protective functions with compact dimensions. The arrestor of the modules can be removed, measured or exchanged during running operation impedance-neutral – without interrupting the measuring circuit. These features make this product the ideal secure protection mechanism for interfaces within instrumentation and control circuits.

Maintenance intervals are simplified by the V-TEST test unit, which is used for testing the function of the VARIRECTOR SPC. This test method satisfies the requirements of standard IEC 62305.

With the VARIRECTOR SPC R modules, error detection and error messages are realised by internal monitoring. The green LED indicates the active protective function. The red LED indicates a fault condition. This information is transmitted to the V-Control evaluation unit. From there, the information can be sent across to e.g. a controller.

Due to the impedance-neutral removing of the arrestor, the VARIRECTOR SPC modules can be used instead of terminals. For four binary signals or two analog signals, just 17.8 mm of space on the mounting rail is used. By simply snapping onto a grounded mounting rail, time savings are also ensured when connecting. A color code identifies the various voltage levels for all VARIRECTOR SPC modules. This simplifies maintenance work during operation. The EMC set offers additional convenience for connecting shielded cables. All VARIRECTOR products comply with the latest IEC 61643-21:2008 requirement for a new overstress mode.

Space-saving

Saves space in the switching cabinet: 4 binary signals or 2 analog signals on 17.8 mm.



Standard-conformant

Usable in accordance with installations standard IEC 62305: safely discharges high impulse currents up to 20 kA (8/20 μ s) and 2.5 kA (10/350 μ s) to PE. Tested for class D1, C1 and C2 to IEC 61643-21:2008.

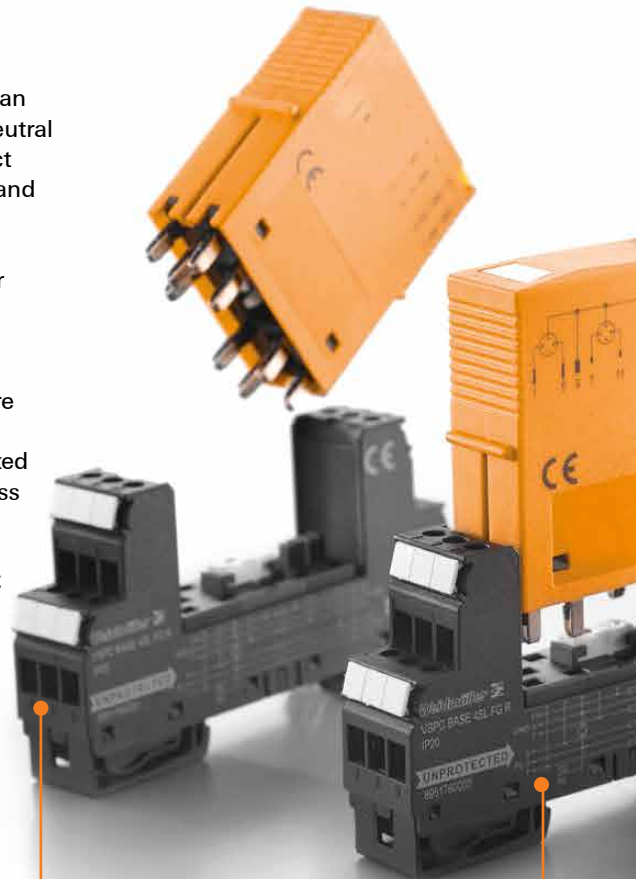

Monitoring function

Status display and message function: the protective function can be evaluated externally.



Quick identification

Color-coded marking: simple identification of the different voltage levels in the switching cabinet.

- ≤ 12 V = green
- 24 V = binary signal, blue
- 24 V = analog signal, yellow
- 48 V = red
- 60 V = violet
- special function = white

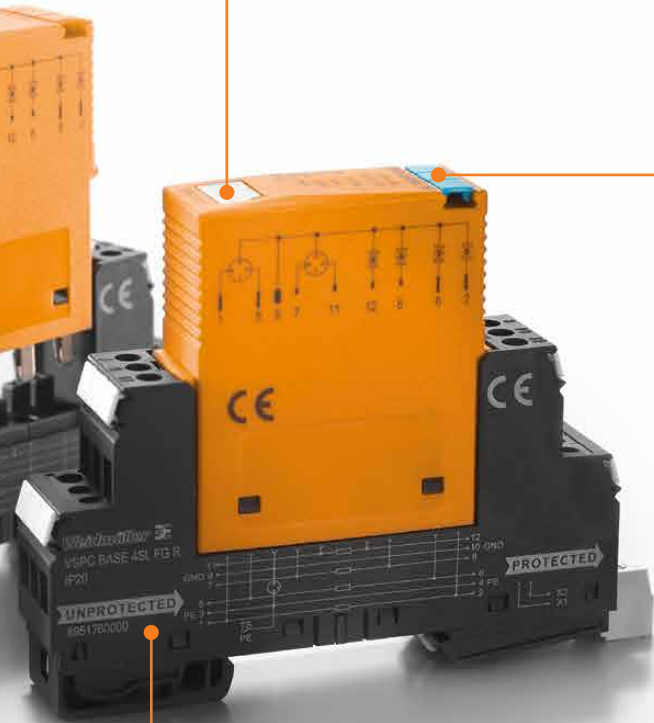
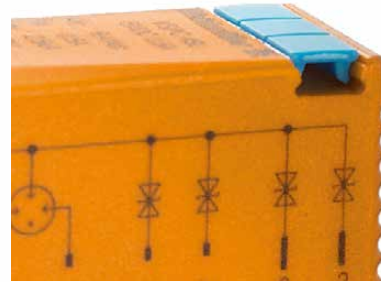

Large variety

A solution for every type of surge protection: current loops and binary signals as well as integrated components and combinations of current loops and voltage supply e.g. 24 V.

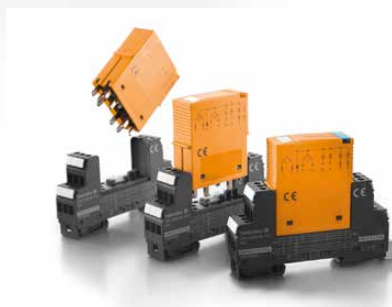

Accessories

EMC-set

Consisting of shield connection and cable binder with shielded sheathing, the EMC set facilitates simple connection of the cable shield to the clamping yoke connections of the VARITECTOR SPC modules.



V-TEST

Instrument for testing the protective function of the product families: PU I, PU II and VSPC to IEC 62305 (periodic testing).



VSPC 1CL - protection for one analog signal

- Optional monitoring function with status indicator and alert function
- Pluggable arrester (impedance-neutral plugging/unplugging without interruption)
- Can be tested with the V-TEST testing device
- Optional version with floating earth PE connection to avoid voltage potential differences
- Usable in accordance with installations standard IEC 62305
- Tested in accordance with IEC 61643-21:08 D1,C1,C2,C3
- Integrated PE foot, safely discharges up to 20 kA (8/20 μs) and 2.5 kA (10/350 μs) to PE

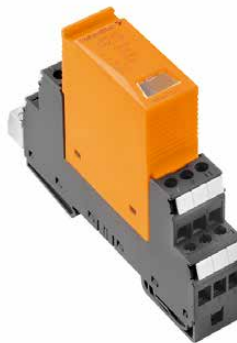

Technical Data

Dielectric strength at FG against PE	≥ 500 V
Volume resistance	2.20 Ω
Overload - failure mode	Modus 2
Requirements category acc. to IEC 61643-21	C1, C2, C3, D1
Surge current-carrying capacity C1	< 1 kA 8/20 μs
Surge current-carrying capacity C2	5 kA 8/20 μs
Surge current-carrying capacity C3	100 A 10/1000 μs
Surge current-carrying capacity D1	2.5 kA 10/350 μs
Discharge current I _s (8/20 μs) wire-wire/wire-PE/GND-PE	2.5 kA / 2.5 kA / 2.5 kA
Discharge I _{max} (8/20 μs) wire-wire/wire-PE/GND-PE	10 kA / 10 kA / 10 kA
Lightning test I _{imp} (10/350 μs) wire-wire/wire-PE/GND-PE	2.5 kA / 2.5 kA / 2.5 kA
Type of connection	Pluggable in VSPC BASE
Storage temperature	-40 °C...+80 °C
Ambient temperature (operational)	-40 °C...+70 °C
Protection degree	IP 20
Failure probability	
Ages	45
MTTF	2537
SIL in compliance with IEC 61508	3
Approvals	
Approvals	CE; GOSTME25; OEVE; TUEV; UL
Standards	IEC 61643-21

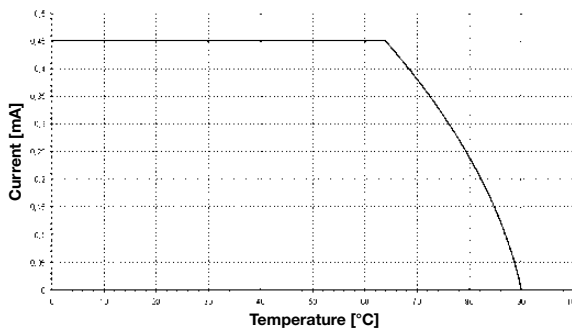
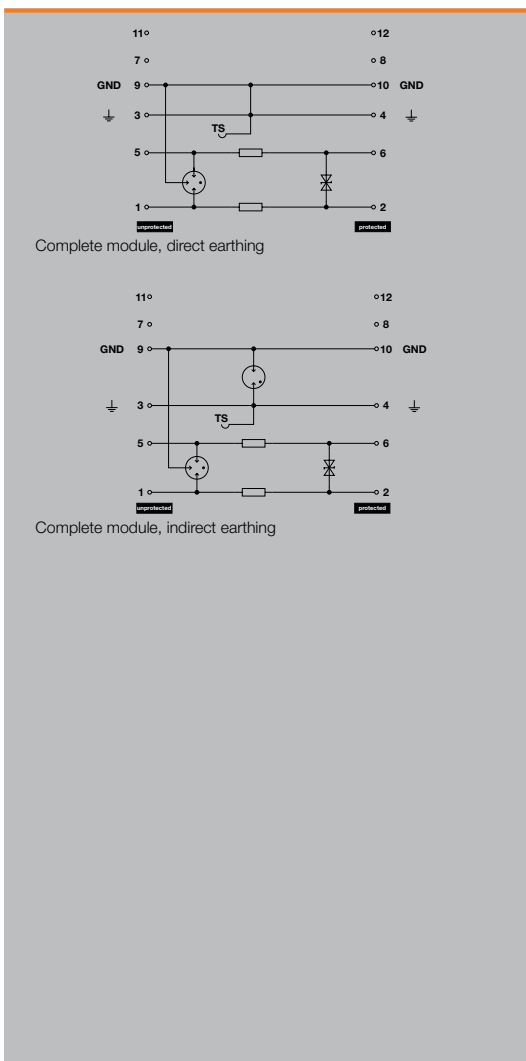

Dimensions of complete module (arrester + base element) no remote sig. contact

Height x width x depth (mm)	90 / 17.8 / 69
-----------------------------	----------------

Note The associated VSPC base element should be ordered with this. The dimension information provided refers to the complete module.

Base elements / base to arresters



Ordering Data (for base)

Description	Type	Qty.	Part No.
Base element, direct earthing	VSPC BASE 1CL	1	8924730000
Base element, indirect earthing / floating earth FG	VSPC BASE 1CL FG	1	8924290000

Note Technical data can be found on page 106.

VSPC 1CL - arrester / plug-in elements



Technical Data

	VSPC 1CL 5 V DC	VSPC 1CL 12 V DC	VSPC 1CL 24 V DC	VSPC 1CL 24 V AC
Rated voltage (AC)				24 V
Rated voltage (DC)	5 V	12 V	24 V	34 V
Max. continuous voltage, U_c (AC)				28 V
Max. continuous voltage, U_c (DC)	6.4 V	15 V	28 V	40 V
Rated current	450 mA	450 mA	450 mA	450 mA
Input attenuation	730 KHz	1.7 MHz	2.4 MHz	2.7 MHz
Pulse-reset capacity	≤ 20 ms	≤ 20 ms	≤ 30 ms	≤ 450 ms
Residual voltage, U_p typical	800 V	800 V	800 V	800 V
Protection level				
Wire-wire 1 kV/ μ s, typically	12 V	25 V	45 V	60 V
Wire-wire 8/20 μ s, typically	12 V	25 V	45 V	60 V
Wire-PE 1 kV/ μ s, typically	450 V	450 V	450 V	450 V
Wire-PE 8/20 μ s, typically	650 V	650 V	650 V	650 V

Ordering Data

No function display	Type	VSPC 1CL 5VDC	VSPC 1CL 12VDC	VSPC 1CL 24VDC	VSPC 1CL 24VAC
	Part No.	8924420000	8924450000	8924480000	8924500000
	Qty.	1 ST	1 ST	1 ST	1 ST
Note					

Technical Data

	VSPC 1CL 48 V AC	VSPC 1CL 60 V AC
Rated voltage (AC)	48 V	60 V
Rated voltage (DC)	68 V	85 V
Max. continuous voltage, U_c (AC)	60 V	72 V
Max. continuous voltage, U_c (DC)	85 V	102 V
Rated current	350 mA	250 mA
Input attenuation	4.8 MHz	7.3 MHz
Pulse-reset capacity	≤ 500 ms	≤ 500 ms
Residual voltage, U_p typical	800 V	800 V
Protection level		
Wire-wire 1 kV/ μ s, typically	85 V	100 V
Wire-wire 8/20 μ s, typically	85 V	100 V
Wire-PE 1 kV/ μ s, typically	450 V	450 V
Wire-PE 8/20 μ s, typically	650 V	650 V

Ordering Data

No function display	Type	VSPC 1CL 48VAC	VSPC 1CL 60VAC
	Part No.	8924520000	8924530000
	Qty.	1 ST	1 ST
Note			

VSPC 1CL - protection for one analog signal with remote alert

- Optional monitoring function with status indicator and alert function
- Pluggable arrester (impedance-neutral plugging/unplugging without interruption)
- Can be tested with the V-TEST testing device
- Optional version with floating earth PE connection to avoid voltage potential differences
- Usable in accordance with installations standard IEC 62305
- Tested in accordance with IEC 61643-21:08 D1,C1,C2,C3
- Integrated PE foot, safely discharges up to 20 kA (8/20 µs) and 2.5 kA (10/350 µs) to PE

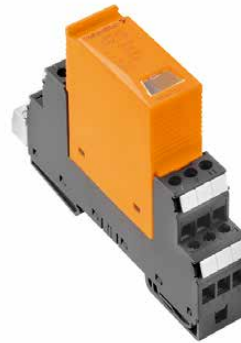

Technical Data

Dielectric strength at FG against PE	≥ 500 V
Volume resistance	2.20 Ω
Overload - failure mode	Modus 2
Requirements category acc. to IEC 61643-21	C1, C2, C3, D1
Surge current-carrying capacity C1	< 1 kA 8/20 µs
Surge current-carrying capacity C2	5 kA 8/20 µs
Surge current-carrying capacity C3	100 A 10/1000 µs
Surge current-carrying capacity D1	2.5 kA 10/350 µs
Discharge current I _s (8/20 µs) wire-wire/wire-PE/GND-PE	2.5 kA / 2.5 kA / 2.5 kA
Discharge I _{max} (8/20 µs) wire-wire/wire-PE/GND-PE	10 kA / 10 kA / 10 kA
Lightning test I _{imp} (10/350 µs) wire-wire/wire-PE/GND-PE	2.5 kA / 2.5 kA / 2.5 kA
Type of connection	Pluggable in VSPC BASE
Storage temperature	-40 °C...+80 °C
Ambient temperature (operational)	-40 °C...+70 °C
Protection degree	IP 20
Failure probability	
Ages	45
MTTF	2537
SIL in compliance with IEC 61508	3
Approvals	
Approvals	CE; GOSTME25; OEVE; TUEV; UL
Standards	IEC 61643-21

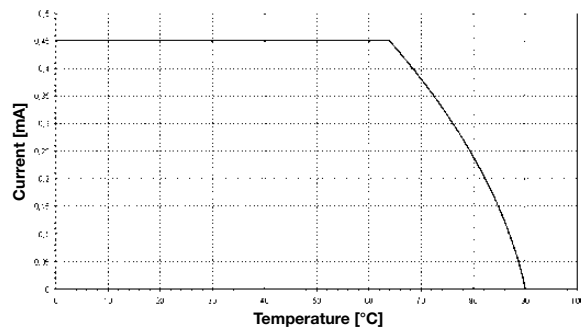
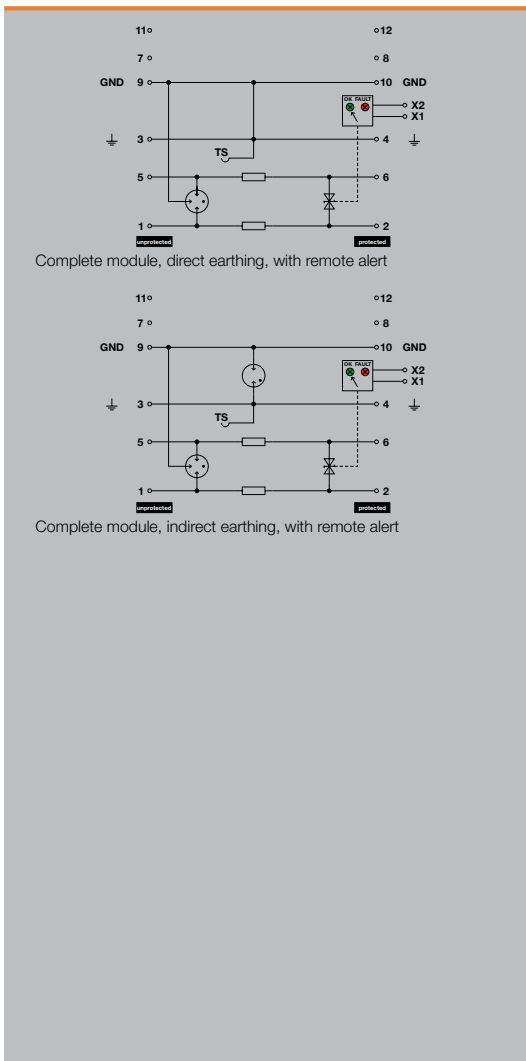

Dimensions of complete module (arrester + base element) with remote signalling (R)

Height x width x depth (mm) 98 / 17.8 / 69

Note The associated VSPC base element should be ordered with this. The dimension information provided refers to the complete module.

Base elements / base to arresters



Ordering Data (for base)

Description	Type	Qty.	Part No.
Base element, indirect earthing with remote contact	VSPC BASE 1CL FG R	1	8951740000
Base element, direct earthing with remote contact	VSPC BASE 1CL R	1	8951730000

Note Technical data can be found on pages 106 and 107. Order with VSPC CONTROL UNIT.

VSPC 1CL - arrester / plug-in components with remote alert



Technical Data

	VSPC 1CL 5 V DC R	VSPC 1CL 12 V DC R	VSPC 1CL 24 V DC R	VSPC 1CL 24 V AC R
Rated voltage (AC)				24 V
Rated voltage (DC)	5 V	12 V	24 V	34 V
Max. continuous voltage, U _c (AC)				28 V
Max. continuous voltage, U _c (DC)	6.4 V	15 V	28 V	40 V
Rated current	450 mA	450 mA	450 mA	450 mA
Signalling contact	U _N 250 V AC 0.1 A 1CO at VSPC R with VSPC CONTROL UNIT	U _N 250 V AC 0.1 A 1CO at VSPC R with VSPC CONTROL UNIT	U _N 250 V AC 0.1 A 1CO at VSPC R with VSPC CONTROL UNIT	U _N 250 V AC 0.1 A 1CO at VSPC R with VSPC CONTROL UNIT
Optical function display	green = OK; red = arrester is defective - replace	green = OK; red = arrester is defective - replace	green = OK; red = arrester is defective - replace	green = OK; red = arrester is defective - replace
Input attenuation	730 KHz	1.7 MHz	2.4 MHz	2.6 MHz
Pulse-reset capacity	20 ms	≤ 20 ms	30 ms	≤ 450 ms
Residual voltage, U _p , typical	800 V	800 V	800 V	800 V
Protection level				
Wire-wire 1 kV/μs, typically	12 V	25 V	45 V	60 V
Wire-wire 8/20 μs, typically	12 V	25 V	45 V	60 V
Wire-PE 1 kV/μs, typically	450 V	450 V	450 V	450 V
Wire-PE 8/20 μs, typically	650 V	650 V	650 V	650 V

Ordering Data

With functional display		VSPC 1CL 5VDC R	VSPC 1CL 12VDC R	VSPC 1CL 24VDC R	VSPC 1CL 24VAC R
Type		VSPC 1CL 5VDC R	VSPC 1CL 12VDC R	VSPC 1CL 24VDC R	VSPC 1CL 24VAC R
Part No.		8951530000	8951540000	8951550000	8951560000
Qty.		1 ST	1 ST	1 ST	1 ST
Note					



VSPC 2CL - protection for two analog signals

- Optional monitoring function with status indicator and alert function
- Pluggable arrester (impedance-neutral plugging/unplugging without interruption)
- Can be tested with the V-TEST testing device
- Version with floating-earth PE connection for avoiding voltage potential differences
- Space-saving design for 2 analog signals with optional alert function and no extra space required
- Usable in accordance with installations standard IEC 62305
- Tested in accordance with IEC 61643-21:08 D1,C1,C2,C3
- Integrated PE foot, safely discharges up to 20 kA (8/20 μs) and 2.5 kA (10/350 μs) to PE

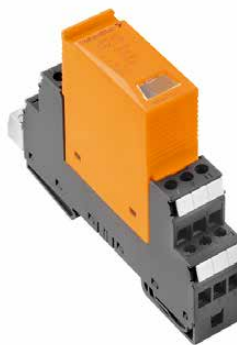

Technical Data

Dielectric strength at FG against PE	≥ 500 V
Volume resistance	2.20 Ω
Overload - failure mode	Modus 2
Requirements category acc. to IEC 61643-21	C1, C2, C3, D1
Surge current-carrying capacity C1	< 1 kA 8/20 μs
Surge current-carrying capacity C2	5 kA 8/20 μs
Surge current-carrying capacity C3	100 A 10/1000 μs
Surge current-carrying capacity D1	2.5 kA 10/350 μs
Discharge current I _s (8/20 μs) wire-wire/wire-PE/GND-PE	2.5 kA / 2.5 kA / 2.5 kA
Discharge I _{max} (8/20 μs) wire-wire/wire-PE/GND-PE	10 kA / 2 x 10 kA / 10 kA
Lightning test I _{imp} (10/350 μs) wire-wire/wire-PE/GND-PE	2.5 kA / 2.5 kA / 2.5 kA
Type of connection	Pluggable in VSPC BASE
Storage temperature	-40 °C...+80 °C
Ambient temperature (operational)	-40 °C...+70 °C
Protection degree	IP 20
Failure probability	
Ages	45
MTTF	2537
SIL in compliance with IEC 61508	3
Approvals	
Approvals	CE; GOSTME25; OEVE; TUEV; UL
Standards	IEC 61643-21

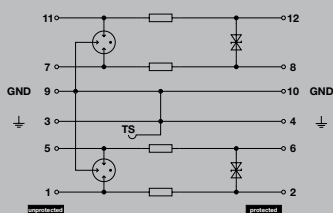

Complete module, direct earthing

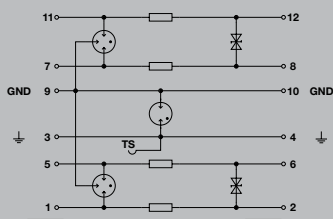

Complete module, indirect earthing

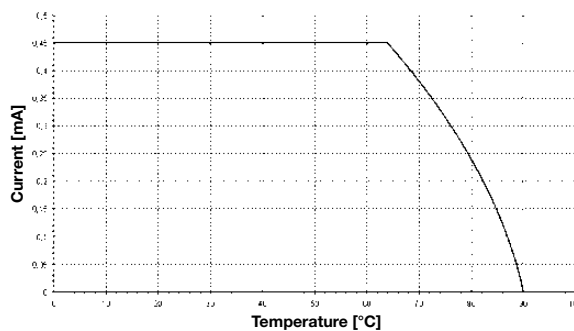

Dimensions of complete module (arrester + base element) no remote sig. contact

Height x width x depth (mm) 90 / 17.8 / 69

Note The associated VSPC base element should be ordered with this. The dimension information provided refers to the complete module.

Base elements / base to arresters



Ordering Data (for base)

Description	Type	Qty.	Part No.
Base element, direct earthing	VSPC BASE 2CL	1	8924710000
Base element, indirect earthing / floating earth FG	VSPC BASE 2CL FG	1	8924270000

Note Technical data can be found on page 106.

VSPC 2CL - arrester / plug-in elements



Technical Data

	VSPC 2CL 5 V DC	VSPC 2CL 12 V DC	VSPC 2CL 24 V DC	VSPC 2CL 24 V AC
Rated voltage (AC)				24 V
Rated voltage (DC)	5 V	12 V	24 V	34 V
Max. continuous voltage, U _c (AC)				28 V
Max. continuous voltage, U _c (DC)	6.4 V	15 V	28 V	40 V
Rated current	450 mA	450 mA	450 mA	450 mA
Input attenuation	730 KHz	1.7 MHz	2.3 MHz	2.7 MHz
Pulse-reset capacity	20 ms	20 ms	30 ms	450 ms
Residual voltage, U _r typical	800 V	800 V	800 V	800 V
Protection level				
Wire-wire 1 kV/μs, typically	12 V	25 V	45 V	60 V
Wire-wire 8/20 μs, typically	12 V	25 V	45 V	60 V
Wire-PE 1 kV/μs, typically	450 V	450 V	450 V	450 V
Wire-PE 8/20 μs, typically	800 V	800 V	800 V	800 V

Ordering Data

No function display				
Type	VSPC 2CL 5VDC	VSPC 2CL 12VDC	VSPC 2CL 24VDC	VSPC 2CL 24VAC
Part No.	8924400000	8924440000	8924470000	8924490000
Qty.	1 ST	1 ST	1 ST	1 ST
Note				

Technical Data

	VSPC 2CL 48 V AC	VSPC 2CL 60 V AC
Rated voltage (AC)	48 V	60 V
Rated voltage (DC)	68 V	85 V
Max. continuous voltage, U _c (AC)	60 V	72 V
Max. continuous voltage, U _c (DC)	85 V	102 V
Rated current	350 mA	250 mA
Input attenuation	4.8 MHz	7.3 MHz
Pulse-reset capacity	500 ms	500 ms
Residual voltage, U _r typical	800 V	800 V
Protection level		
Wire-wire 1 kV/μs, typically	85 V	100 V
Wire-wire 8/20 μs, typically	85 V	100 V
Wire-PE 1 kV/μs, typically	450 V	450 V
Wire-PE 8/20 μs, typically	650 V	650 V

Ordering Data

No function display		
Type	VSPC 2CL 48VAC	VSPC 2CL 60VAC
Part No.	8951490000	8951500000
Qty.	1 ST	1 ST
Note		



VSPC 2CL - protection for two analog signals with remote alert

- Optional monitoring function with status indicator and alert function
- Pluggable arrester (impedance-neutral plugging/unplugging without interruption)
- Can be tested with the V-TEST testing device
- Version with floating-earth PE connection for avoiding voltage potential differences
- Space-saving design for 2 analog signals with optional alert function and no extra space required
- Usable in accordance with installation standard IEC 62305
- Tested in accordance with IEC 61643-21:08 D1, C1, C2, C3
- Integrated PE foot, safely discharges up to 20 kA (8/20 μs) and 2.5 kA (10/350 μs) to PE

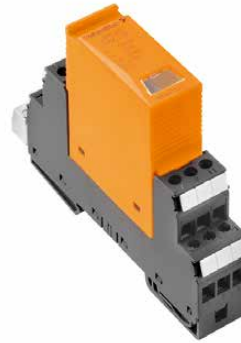

Technical Data

Dielectric strength at FG against PE	≥ 500 V
Volume resistance	2.20 Ω
Overload - failure mode	Modus 2
Requirements category acc. to IEC 61643-21	C1, C2, C3, D1
Surge current-carrying capacity C1	< 1 kA 8/20 μs
Surge current-carrying capacity C2	5 kA 8/20 μs
Surge current-carrying capacity C3	100 A 10/1000 μs
Surge current-carrying capacity D1	2.5 kA 10/350 μs
Discharge current I _d (8/20 μs) wire-wire/wire-PE/GND-PE	2.5 kA / 2.5 kA / 2.5 kA
Discharge I _{max} (8/20 μs) wire-wire/wire-PE/GND-PE	10 kA / 2 x 10 kA / 10 kA
Lightning test I _{imp} (10/350 μs) wire-wire/wire-PE/GND-PE	2.5 kA / 2.5 kA / 2.5 kA
Type of connection	Pluggable in VSPC BASE
Storage temperature	-40 °C...+80 °C
Ambient temperature (operational)	-40 °C...+70 °C
Protection degree	IP 20
Failure probability	
Ages	45
MTTF	2537
SIL in compliance with IEC 61508	3
Approvals	
Approvals	CE; GOSTME25; OEVE; TUEV; UL
Standards	IEC 61643-21

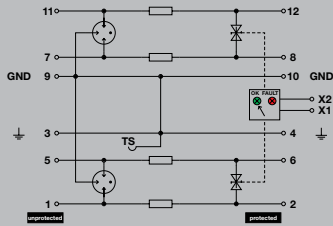

Complete module, direct earthing, with remote alert

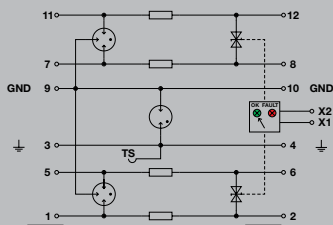

Complete module, indirect earthing, with remote alert

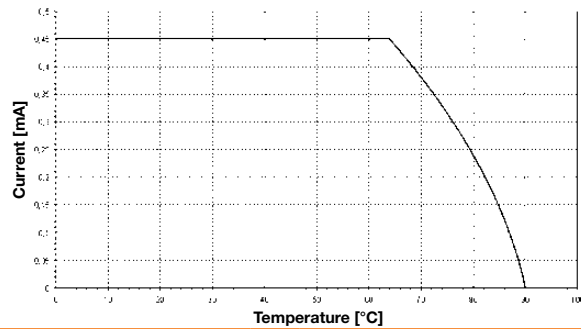

Dimensions of complete module (arrester + base element) with remote signalling (R)

Height x width x depth (mm) 98 / 17.8 / 69

Note The associated VSPC base element should be ordered with this. The dimension information provided refers to the complete module.

Base elements / base to arresters



Ordering Data (for base)

Description	Type	Qty.	Part No.
Base element, indirect earthing with remote contact	VSPC BASE 2CL FG R	1	8951720000
Base element, direct earthing with remote contact	VSPC BASE 2CL R	1	8951710000

Note Technical data can be found on page 106. Order with VSPC CONTROL UNIT.

VSPC 2CL - arrester / plug-in components with remote alert



Technical Data

	VSPC 2CL 5 V DC R	VSPC 2CL 12 V DC R	VSPC 2CL 24 V DC R	VSPC 2CL 24 V AC R
Rated voltage (AC)				24 V
Rated voltage (DC)	5 V	12 V	24 V	34 V
Max. continuous voltage, U _c (AC)				28 V
Max. continuous voltage, U _c (DC)	6.4 V	15 V	28 V	40 V
Rated current	450 mA	450 mA	450 mA	450 mA
Signalling contact	U _N 250 V AC 0.1 A 1CO at VSPC R with VSPC CONTROL UNIT	U _N 250 V AC 0.1 A 1CO at VSPC R with VSPC CONTROL UNIT	U _N 250 V AC 0.1 A 1CO at VSPC R with VSPC CONTROL UNIT	U _N 250 V AC 0.1 A 1CO at VSPC R with VSPC CONTROL UNIT
Optical function display	green = OK; red = arrester is defective - replace	green = OK; red = arrester is defective - replace	green = OK; red = arrester is defective - replace	green = OK; red = arrester is defective - replace
Input attenuation	730 KHz	1.7 MHz	2.3 MHz	2.7 MHz
Pulse-reset capacity	20 ms	20 ms	30 ms	450 ms
Residual voltage, U _p typical	800 V	800 V	800 V	
Protection level				
Wire-wire 1 kV/μs, typically	12 V	25 V	45 V	60 V
Wire-wire 8/20 μs, typically	12 V	25 V	45 V	60 V
Wire-PE 1 kV/μs, typically	450 V	450 V	450 V	450 V
Wire-PE 8/20 μs, typically	800 V	800 V	800 V	800 V

Ordering Data

With functional display					
Type		VSPC 2CL 5VDC R	VSPC 2CL 12VDC R	VSPC 2CL 24VDC R	VSPC 2CL 24VAC R
Part No.		8951460000	8951470000	8951480000	1093400000
Qty.		1 ST	1 ST	1 ST	1 ST
Note					



VSPC 1CL PW - combination of current loop protection and end device protection

- Pluggable arrester (impedance-neutral plugging/unplugging without interruption)
- Can be tested with the V-TEST testing device
- Version with floating-earth PE connection for avoiding voltage potential differences
- Usable in accordance with installations standard IEC 62305
- Tested in accordance with IEC 61643-21:08 D1,C1,C2,C3
- Tested in accordance with IEC 61643-11:09 Class III
- Integrated PE foot, safely discharges up to 20 kA (8/20 µs) and 2.5 kA (10/350 µs) to PE

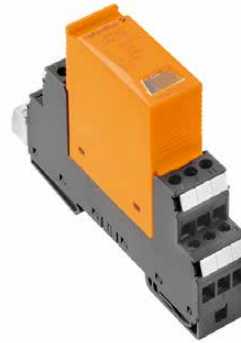

Technical Data

Measurement and control protection data	
Dielectric strength at FG against PE	≥ 500 V
Volume resistance	2.20 Ω
Rated current	450 mA
Overload - failure mode	Modus 2
Requirements category acc. to IEC 61643-21	C1, C2, C3, D1
Surge current-carrying capacity C1	< 1 kA 8/20 µs
Surge current-carrying capacity C2	5 kA 8/20 µs
Surge current-carrying capacity C3	100 A 10/1000 µs
Surge current-carrying capacity D1	2.5 kA 10/350 µs
Standards	IEC 61643-21
Discharge current I _s (8/20µs) wire-wire	2.5 kA / 2.5 kA / 2.5 kA
Discharge I _{max} (8/20 µs) wire-wire/wire-PE/GND-PE	10 kA / 10 kA / 10 kA
Lightning test current, I _{imp} (10/350 µs) wire-wire	2.5 kA / 2.5 kA / 2.5 kA
End device protection data	
Combined pulse U _{oc}	6 kV
Max. continuous voltage, U _c (DC)	38 V
Residual voltage, U _r typical	900 V
Rated current	10 A
General data	
Type of connection	Pluggable in VSPC BASE
Storage temperature	-40 °C...+80 °C
Requirements category acc. to IEC 61643-21	C1, C2, C3, D1
Ambient temperature (operational)	-40 °C...+70 °C
Protection degree	IP 20
Failure probability	
λ _{ges}	45
MTTF	2537
SIL in compliance with IEC 61508	3
Approvals	
Approvals	CE; GOSTME25; OEVE; TUEV; UL
Standards	IEC 61643-21

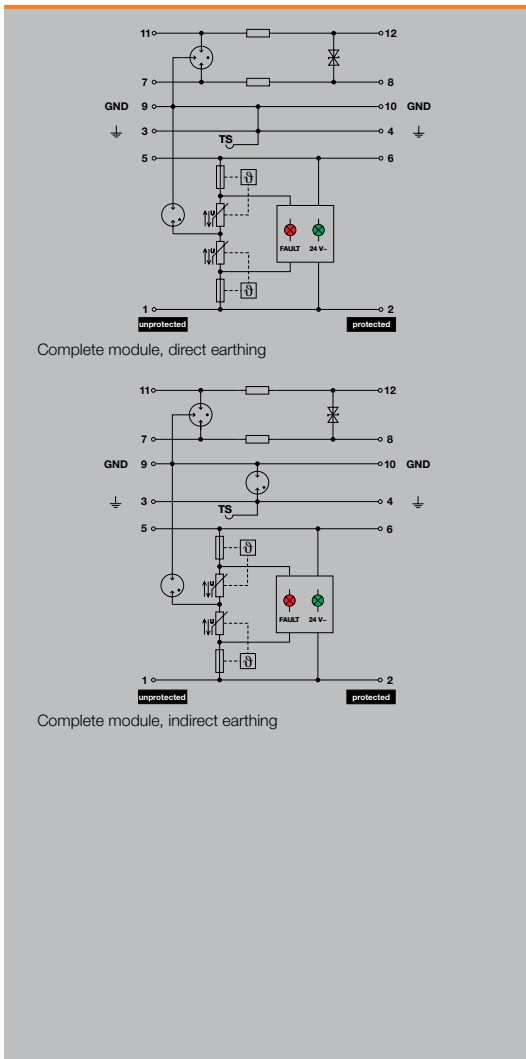

Dimensions of complete module (arrester + base element) no remote sig. contact	
Height x width x depth (mm)	90 / 17.8 / 69
Note	The associated VSPC base element should be ordered with this. The dimension information provided refers to the complete module.

Base elements / base to arresters



Ordering Data (for base)

Description	Type	Qty.	Part No.
Base element, indirect earthing / floating earth FG	VSPC BASE 1CL PW FG	1	1105700000
Base element, direct earthing	VSPC BASE 1CL PW	1	1070230000

Note Technical data can be found on page 106.

VSPC 1CL PW - arrester / plug-in components



Technical Data

Rated voltage (AC)
Rated voltage (DC)
Max. continuous voltage, U _c (AC)
Max. continuous voltage, U _c (DC)
Signalling contact
Optical function display
Input attenuation
Pulse-reset capacity
Residual voltage, U _r , typical

Protection level

Wire-wire 1 kV/μs, typically
Wire-wire 8/20 μs, typically
Wire-PE 1kV/μs, typically
Wire-PE 8/20 μs, typically

VSPC 1CL PW 24 V DC

34 V
24 V
27 V
38 V
For Class III protection, green = OK; red = arrester is defective - replace
3 MHz
≤ 10 ms
900 V
60 V
60 V
450 V
650 V

Ordering Data

No function display

Type	VSPC 1CL PW 24V
Part No.	8951510000
Qty.	1 ST

Note



VSPC 2SL - protection for two binary signals

- Optional monitoring function with status indicator and alert function
- Pluggable arrester (impedance-neutral plugging/unplugging without interruption)
- Can be tested with the V-TEST testing device
- Version with floating-earth PE connection for avoiding voltage potential differences
- Usable in accordance with installations standard IEC 62305
- Tested in accordance with IEC 61643-21:08 D1,C1,C2,C3
- Integrated PE foot, safely discharges up to 20 kA (8/20 μs) and 2.5 kA (10/350 μs) to PE

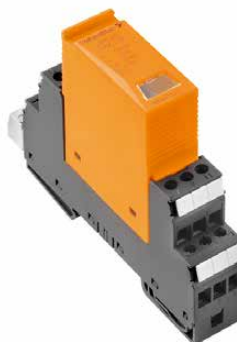

Technical Data

Dielectric strength at FG against PE	≥ 500 V
Volume resistance	4.7 Ω
Overload - failure mode	Modus 2
Requirements category acc. to IEC 61643-21	C1, C2, C3, D1
Surge current-carrying capacity C1	< 1 kA 8/20 μs
Surge current-carrying capacity C2	5 kA 8/20 μs
Surge current-carrying capacity C3	100 A 10/1000 μs
Surge current-carrying capacity D1	2.5 kA 10/350 μs
Discharge current I _s (8/20 μs) wire-wire/wire-PE/GND-PE	2.5 kA / 2.5 kA / 2.5 kA
Discharge I _{max} (8/20 μs) wire-wire/wire-PE/GND-PE	10 kA / 10 kA / 10 kA
Lightning test I _{imp} (10/350 μs) wire-wire/wire-PE/GND-PE	2.5 kA / 2.5 kA / 2.5 kA
Type of connection	Pluggable in VSPC BASE
Storage temperature	-40 °C...+80 °C
Ambient temperature (operational)	-40 °C...+70 °C
Protection degree	IP 20
Failure probability	
Ages	43
MTTF	2665
SIL in compliance with IEC 61508	2
Approvals	
Approvals	CE; GOSTME25; OEVE; TUEV; UL
Standards	IEC 61643-21

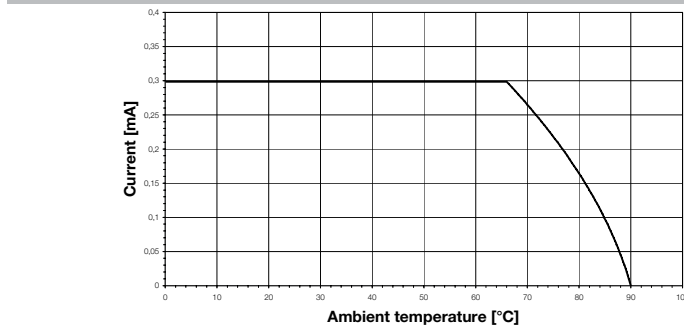
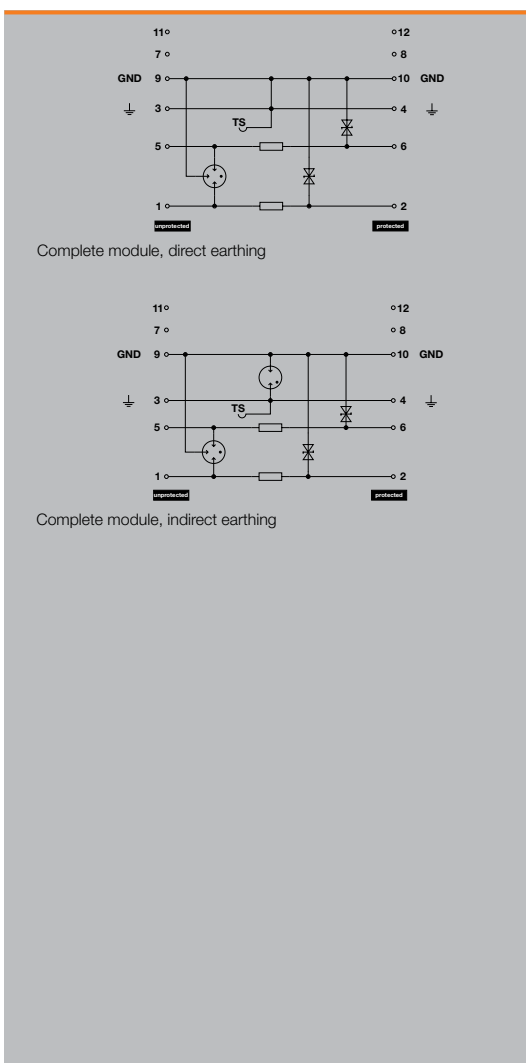

Dimensions of complete module (arrester + base element) no remote sig. contact	
Height x width x depth (mm)	90 / 17.8 / 69

Note The associated VSPC base element should be ordered with this. The dimension information provided refers to the complete module.

Base elements / base to arresters



Ordering Data (for base)

Description	Type	Qty.	Part No.
Base element, direct earthing	VSPC BASE 2SL	1	8924720000
Base element, indirect earthing / floating earth FG	VSPC BASE 2SL FG	1	8924280000

Note Technical data can be found on page 106.

VSPC 2SL - arrester / plug-in components



Technical Data

	VSPC 2SL 5 V DC	VSPC 2SL 12 V DC	VSPC 2SL 12 V AC	VSPC 2SL 24 V DC
Rated voltage (AC)			12 V	
Rated voltage (DC)	5 V	12 V	16 V	24 V
Max. continuous voltage, U _c (AC)			13.2 V	
Max. continuous voltage, U _c (DC)	6.4 V	15 V	18.5 V	28 V
Rated current	300 mA	300 mA	300 mA	300 mA
Input attenuation	1.2 MHz	2.5 MHz	3.2 MHz	2.7 MHz
Pulse-reset capacity	20 ms	20 ms	20 ms	30 ms
Residual voltage, U _p typical	25 V	50 V	50 V	60 V
Protection level				
Wire-wire 1 kV/μs, typically	25 V	45 V	55 V	80 V
Wire-wire 8/20 μs, typically	25 V	45 V	55 V	80 V
Wire-PE 1kV/μs, typically	12 V	25 V	30 V	40 V
Wire-PE 8/20 μs, typically	25 V	50 V	50 V	60 V

Ordering Data

No function display	Type	VSPC 2SL 5VDC	VSPC 2SL 12VDC	VSPC 2SL 12VAC	VSPC 2SL 24VDC
	Part No.	8924210000	8924230000	8924250000	8924330000
	Qty.	1 ST	1 ST	1 ST	1 ST
Note					

Technical Data

	VSPC 2SL 24 V AC	VSPC 2SL 48 V AC	VSPC 2SL 60 V AC
Rated voltage (AC)	24 V	48 V	60 V
Rated voltage (DC)	34 V	68 V	85 V
Max. continuous voltage, U _c (AC)	28 V	60 V	72 V
Max. continuous voltage, U _c (DC)	40 V	85 V	102 V
Rated current	300 mA	250 mA	200 mA
Input attenuation	5.5 MHz	8.7 MHz	13.6 MHz
Pulse-reset capacity	60 ms	60 ms	60 ms
Residual voltage, U _p typical	60 V	125 V	165 V
Protection level			
Wire-wire 1 kV/μs, typically	110 V	210 V	280 V
Wire-wire 8/20 μs, typically	80 V	80 V	80 V
Wire-PE 1kV/μs, typically	60 V	85 V	100 V
Wire-PE 8/20 μs, typically	60 V	125 V	165 V

Ordering Data

No function display	Type	VSPC 2SL 24VAC	VSPC 2SL 48VAC	VSPC 2SL 60VAC
	Part No.	8924350000	8924370000	8924390000
	Qty.	1 ST	1 ST	1 ST
Note				



VSPC 2SL - protection for two binary signals with remote alert

- Optional monitoring function with status indicator and alert function
- Pluggable arrester (impedance-neutral plugging/unplugging without interruption)
- Can be tested with the V-TEST testing device
- Version with floating-earth PE connection for avoiding voltage potential differences
- Usable in accordance with installations standard IEC 62305
- Tested in accordance with IEC 61643-21:08 D1,C1,C2,C3
- Integrated PE foot, safely discharges up to 20 kA (8/20 µs) and 2.5 kA (10/350 µs) to PE

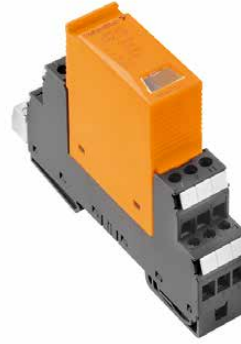

Technical Data

Dielectric strength at FG against PE	≥ 500 V
Volume resistance	4.7 Ω
Overload - failure mode	Modus 2
Requirements category acc. to IEC 61643-21	C1, C2, C3, D1
Surge current-carrying capacity C1	< 1 kA 8/20 µs
Surge current-carrying capacity C2	5 kA 8/20 µs
Surge current-carrying capacity C3	100 A 10/1000 µs
Surge current-carrying capacity D1	2.5 kA 10/350 µs
Discharge current I ₁ (8/20 µs) wire-wire/wire-PE/GND-PE	2.5 kA / 2.5 kA / 2.5 kA
Discharge I _{max} (8/20 µs) wire-wire/wire-PE/GND-PE	10 kA / 10 kA / 10 kA
Lightning test I _{imp} (10/350 µs) wire-wire/wire-PE/GND-PE	2.5 kA / 2.5 kA / 2.5 kA
Type of connection	Pluggable in VSPC BASE
Storage temperature	-40 °C...+80 °C
Ambient temperature (operational)	-40 °C...+70 °C
Protection degree	IP 20
Failure probability	
Ages	43
MTTF	2665
SIL in compliance with IEC 61508	2
Approvals	
Approvals	CE; GOSTME25; OEVE; TUEV; UL
Standards	IEC 61643-21

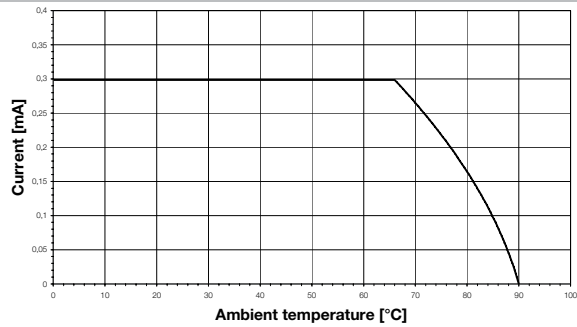
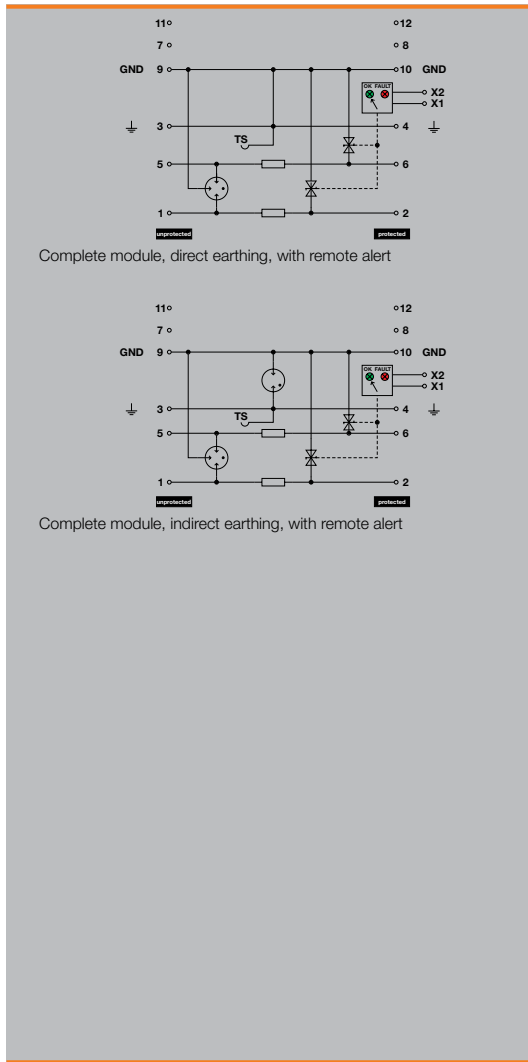

Dimensions of complete module (arrester + base element) with remote signalling (R)	
Height x width x depth (mm)	98 / 17.8 / 69
Note	The associated VSPC base element should be ordered with this. The dimension information provided refers to the complete module.

Base elements / base to arresters



Ordering Data (for base)

Description	Type	Qty.	Part No.
Base element, indirect earthing with remote contact	VSPC BASE 2SL FG R	1	8951780000
Base element, direct earthing with remote contact	VSPC BASE 2SL R	1	8951770000

Note Technical data can be found on page 107. Order with VSPC CONTROL UNIT.

VSPC 2SL - arrester / plug-in elements with remote alert



Technical Data

	VSPC 2SL 5 V DC R	VSPC 2SL 12 V DC R	VSPC 2SL 24 V DC R	VSPC 2SL 24 V AC R
Rated voltage (AC)				24 V
Rated voltage (DC)	5 V	12 V	24 V	34 V
Max. continuous voltage, U _c (AC)				28 V
Max. continuous voltage, U _c (DC)	6.4 V	15 V	28 V	40 V
Rated current	300 mA	300 mA	300 mA	300 mA
Signalling contact	U _N 250 V AC 0.1 A 1CO at VSPC R with VSPC CONTROL UNIT	U _N 250 V AC 0.1 A 1CO at VSPC R with VSPC CONTROL UNIT	U _N 250 V AC 0.1 A 1CO at VSPC R with VSPC CONTROL UNIT	U _N 250 V AC 0.1 A 1CO at VSPC R with VSPC CONTROL UNIT
Optical function display	green = OK; red = arrester is defective - replace	green = OK; red = arrester is defective - replace	green = OK; red = arrester is defective - replace	green = OK; red = arrester is defective - replace
Input attenuation	1.2 MHz	2.5 MHz	2.7 MHz	5.5 MHz
Pulse-reset capacity	20 ms	20 ms	30 ms	60 ms
Residual voltage, U _p , typical	25 V	50 V	60 V	60 V
Protection level				
Wire-wire 1 kV/μs, typically	25 V	45 V	80 V	110 V
Wire-wire 8/20 μs, typically	25 V	45 V	80 V	80 V
Wire-PE 1 kV/μs, typically	12 V	25 V	40 V	60 V
Wire-PE 8/20 μs, typically	25 V	50 V	60 V	60 V

Ordering Data

With functional display		VSPC 2SL 5VDC R	VSPC 2SL 12VDC R	VSPC 2SL 24VDC R	VSPC 2SL 24VAC R
Type		VSPC 2SL 5VDC R	VSPC 2SL 12VDC R	VSPC 2SL 24VDC R	VSPC 2SL 24VAC R
Part No.		8951610000	8951620000	8951630000	8951640000
Qty.		1 ST	1 ST	1 ST	1 ST
Note					



VSPC 4SL - protection for four binary signals

- Optional monitoring function with status indicator and alert function
- Pluggable arrester (impedance-neutral plugging/unplugging without interruption)
- Can be tested with the V-TEST testing device
- Version with floating-earth PE connection for avoiding voltage potential differences
- Space-saving design for 4 binary signals with optional alert function and no extra space required
- Usable in accordance with installation standard IEC 62305
- Tested in accordance with IEC 61643-21:08 D1, C1, C2, C3
- Integrated PE foot, safely discharges up to 20 kA (8/20 μs) and 2.5 kA (10/350 μs) to PE

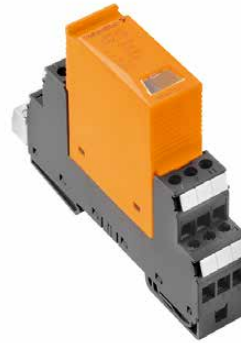

Technical Data

Dielectric strength at FG against PE	≥ 500 V
Volume resistance	4.7 Ω
Overload - failure mode	Modus 2
Requirements category acc. to IEC 61643-21	C1, C2, C3, D1
Surge current-carrying capacity C1	< 1 kA 8/20 μs
Surge current-carrying capacity C2	5 kA 8/20 μs
Surge current-carrying capacity C3	100 A 10/1000 μs
Surge current-carrying capacity D1	2.5 kA 10/350 μs
Discharge current I _a (8/20 μs) wire-wire/wire-PE/GND-PE	2.5 kA / 2.5 kA / 2.5 kA
Discharge I _{max} (8/20 μs) wire-wire/wire-PE/GND-PE	10 kA / 10 kA / 10 kA
Lightning test I _{imp} (10/350 μs) wire-wire/wire-PE/GND-PE	2.5 kA / 2.5 kA / 2.5 kA
Type of connection	Pluggable in VSPC BASE
Storage temperature	-40 °C...+80 °C
Ambient temperature (operational)	-40 °C...+70 °C
Protection degree	IP 20
Failure probability	
Ages	43
MTTF	2665
SIL in compliance with IEC 61508	2
Approvals	
Approvals	CE; GOSTME25; OEVE; TUEV; UL
Standards	IEC 61643-21

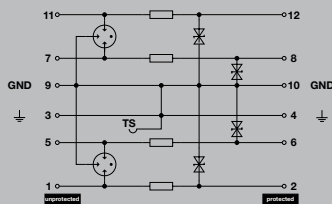

Complete module, direct earthing

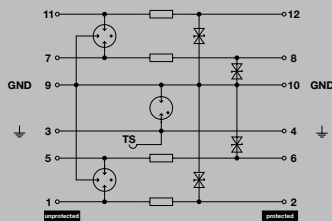

Complete module, indirect earthing

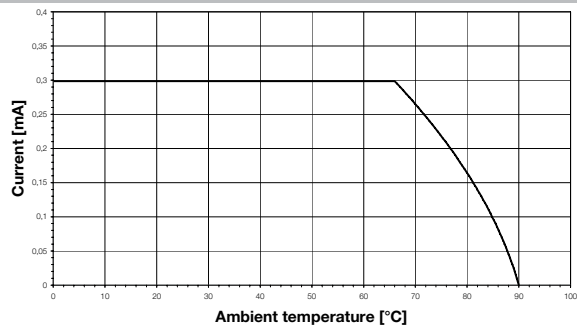

Dimensions of complete module (arrester + base element) no remote sig. contact	
Height x width x depth (mm)	90 / 17.8 / 69

Note The associated VSPC base element should be ordered with this. The dimension information provided refers to the complete module.

Base elements / base to arresters



Ordering Data (for base)

Description	Type	Qty.	Part No.
Base element, direct earthing	VSPC BASE 4SL	1	8924700000
Base element, indirect earthing / floating earth FG	VSPC BASE 4SL FG	1	8924260000

Note Technical data can be found on page 106.

VSPC 4SL - arrester / plug-in elements



Technical Data

	VSPC 4SL 5 V DC	VSPC 4SL 12 V DC	VSPC 4SL 12 V AC	VSPC 4SL 24 V DC
Rated voltage (AC)			12 V	
Rated voltage (DC)	5 V	12 V	16 V	24 V
Max. continuous voltage, U _c (AC)			13.2 V	
Max. continuous voltage, U _c (DC)	6.4 V	15 V	18 V	28 V
Rated current	300 mA	300 mA	300 mA	300 mA
Input attenuation	1.2 MHz	2.5 MHz	3.2 MHz	4 MHz
Pulse-reset capacity	20 ms	20 ms	20 ms	30 ms
Residual voltage, U _p typical	25 V	35 V	50 V	60 V
Protection level				
Wire-wire 1 kV/μs, typically	25 V	45 V	55 V	80 V
Wire-wire 8/20 μs, typically	25 V	45 V	55 V	80 V
Wire-PE 1 kV/μs, typically	12 V	25 V	30 V	40 V
Wire-PE 8/20 μs, typically	25 V	50 V	50 V	60 V

Ordering Data

No function display	Type	VSPC 4SL 5VDC	VSPC 4SL 12VDC	VSPC 4SL 12VAC	VSPC 4SL 24VDC
	Part No.	8924200000	8924220000	8924240000	8924320000
	Qty.	1 ST	1 ST	1 ST	1 ST
Note					

Technical Data

	VSPC 4SL 24 V AC	VSPC 4SL 48 V AC	VSPC 4SL 60 V AC
Rated voltage (AC)	24 V	48 V	60 V
Rated voltage (DC)	34 V	68 V	85 V
Max. continuous voltage, U _c (AC)	28 V	60 V	72 V
Max. continuous voltage, U _c (DC)	39 V	85 V	101 V
Rated current	300 mA	250 mA	200 mA
Input attenuation	2.7 MHz	8.7 MHz	13.6 MHz
Pulse-reset capacity	40 ms	60 ms	60 ms
Residual voltage, U _p typical	60 V	125 V	165 V
Protection level			
Wire-wire 1 kV/μs, typically	110 V	210 V	280 V
Wire-wire 8/20 μs, typically	80 V	80 V	80 V
Wire-PE 1 kV/μs, typically	60 V	85 V	110 V
Wire-PE 8/20 μs, typically	60 V	125 V	165 V

Ordering Data

No function display	Type	VSPC 4SL 24VAC	VSPC 4SL 48VAC	VSPC 4SL 60VAC
	Part No.	8924340000	8924360000	8924380000
	Qty.	1 ST	1 ST	1 ST
Note				



VSPC 4SL - protection for four binary signals with remote alert

- Optional monitoring function with status indicator and alert function
- Pluggable arrester (impedance-neutral plugging/unplugging without interruption)
- Can be tested with the V-TEST testing device
- Version with floating-earth PE connection for avoiding voltage potential differences
- Space-saving design for 4 binary signals with optional alert function and no extra space required
- Usable in accordance with installation standard IEC 62305
- Tested in accordance with IEC 61643-21:08 D1, C1, C2, C3
- Integrated PE foot, safely discharges up to 20 kA (8/20 μs) and 2.5 kA (10/350 μs) to PE

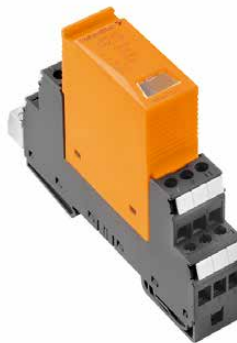

Technical Data

Dielectric strength at FG against PE	≥ 500 V
Volume resistance	4.7 Ω
Overload - failure mode	Modus 2
Requirements category acc. to IEC 61643-21	C1, C2, C3, D1
Surge current-carrying capacity C1	< 1 kA 8/20 μs
Surge current-carrying capacity C2	5 kA 8/20 μs
Surge current-carrying capacity C3	100 A 10/1000 μs
Surge current-carrying capacity D1	2.5 kA 10/350 μs
Discharge current I _d (8/20 μs) wire-wire/wire-PE/GND-PE	2.5 kA / 2.5 kA / 2.5 kA
Discharge I _{max} (8/20 μs) wire-wire/wire-PE/GND-PE	10 kA / 10 kA / 10 kA
Lightning test I _{imp} (10/350 μs) wire-wire/wire-PE/GND-PE	2.5 kA / 2.5 kA / 2.5 kA
Type of connection	Pluggable in VSPC BASE
Storage temperature	-40 °C...+80 °C
Ambient temperature (operational)	-40 °C...+70 °C
Protection degree	IP 20
Failure probability	
Ages	43
MTTF	2665
SIL in compliance with IEC 61508	2
Approvals	
Approvals	CE; GOSTME25; OEVE; TUEV; UL
Standards	IEC 61643-21

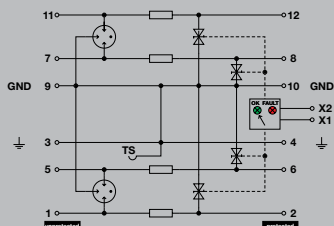

Complete module, direct earthing, with remote alert

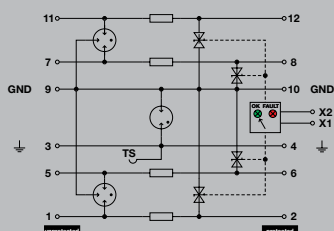

Complete module, indirect earthing, with remote alert

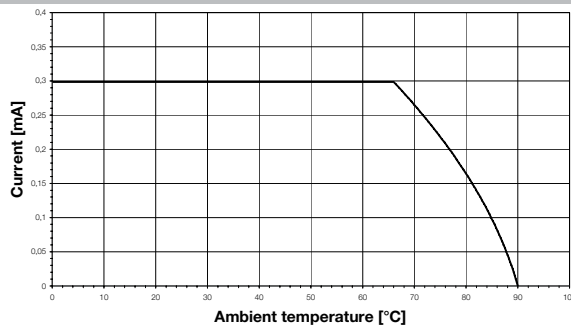

Dimensions of complete module (arrester + base element) with remote signalling (R)

Height x width x depth (mm) 98 / 17.8 / 69

Note The associated VSPC base element should be ordered with this. The dimension information provided refers to the complete module.

Base elements / base to arresters



Ordering Data (for base)

Description	Type	Qty.	Part No.
Base element, indirect earthing with remote contact	VSPC BASE 4SL FG R	1	8951760000
Base element, direct earthing with remote contact	VSPC BASE 4SL R	1	8951750000

Note Technical data can be found on page 107. Order with VSPC CONTROL UNIT.

VSPC 4SL - arrester / plug-in elements with remote alert



Technical Data

	VSPC 4SL 5 V DC R	VSPC 4SL 12 V DC R	VSPC 4SL 24 V DC R	VSPC 4SL 24 V AC R
Rated voltage (AC)				24 V
Rated voltage (DC)	5 V	12 V	24 V	34 V
Max. continuous voltage, U _c (AC)				28 V
Max. continuous voltage, U _c (DC)	6.4 V	15 V	28 V	39 V
Rated current	300 mA	300 mA	300 mA	300 mA
Signalling contact	U _N 250 V AC 0.1 A 1CO at VSPC R with VSPC CONTROL UNIT	U _N 250 V AC 0.1 A 1CO at VSPC R with VSPC CONTROL UNIT	U _N 250 V AC 0.1 A 1CO at VSPC R with VSPC CONTROL UNIT	U _N 250 V AC 0.1 A 1CO at VSPC R with VSPC CONTROL UNIT
Optical function display	green = OK; red = arrester is defective - replace	green = OK; red = arrester is defective - replace	green = OK; red = arrester is defective - replace	green = OK; red = arrester is defective - replace
Input attenuation	1.2 MHz	2.5 MHz	4 MHz	2.7 MHz
Pulse-reset capacity	20 ms	20 ms	30 ms	40 ms
Residual voltage, U _p , typical	25 V	35 V	60 V	60 V
Protection level				
Wire-wire 1 kV/μs, typically	25 V	45 V	80 V	110 V
Wire-wire 8/20 μs, typically	25 V	45 V	80 V	80 V
Wire-PE 1 kV/μs, typically	12 V	25 V	40 V	60 V
Wire-PE 8/20 μs, typically	25 V	50 V	60 V	60 V

Ordering Data

With functional display		VSPC 4SL 5VDC R	VSPC 4SL 12VDC R	VSPC 4SL 24VDC R	VSPC 4SL 24VAC R
Type		VSPC 4SL 5VDC R	VSPC 4SL 12VDC R	VSPC 4SL 24VDC R	VSPC 4SL 24VAC R
Part No.		8951570000	8951580000	8951590000	8951600000
Qty.		1 ST	1 ST	1 ST	1 ST
Note					



VSPC 4 SL WIRE - protection for 3/4-wire signals

- Protection of measuring bridge signals
- Pluggable arrester (impedance-neutral plugging/unplugging without interruption)
- Can be tested with the V-TEST testing device
- Version with floating-earth PE connection for avoiding voltage potential differences
- Space-saving design for 4 binary signals with optional alert function and no extra space required
- Usable in accordance with installations standard IEC 62305
- Tested in accordance with IEC 61643-21:08 D1,C1,C2,C3
- Integrated PE foot, safely discharges up to 20 kA (8/20 μs) and 2.5 kA (10/350 μs) to PE

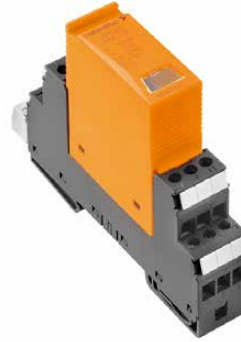

Technical Data

Dielectric strength at FG against PE	≥ 500 V
Volume resistance	0.20 Ω
Overload - failure mode	Modus 2
Requirements category acc. to IEC 61643-21	C1, C2, C3, D1
Surge current-carrying capacity C1	< 1 kA 8/20 μs
Surge current-carrying capacity C2	5 kA 8/20 μs
Surge current-carrying capacity C3	100 A 10/1000 μs
Surge current-carrying capacity D1	2.5 kA 10/350 μs
Discharge current I ₁ (8/20 μs) wire-wire/wire-PE/GND-PE	2.5 kA / 2.5 kA / 2.5 kA
Discharge I _{max} (8/20 μs) wire-wire/wire-PE/GND-PE	10 kA / 10 kA / 10 kA
Lightning test I _{imp} (10/350 μs) wire-wire/wire-PE/GND-PE	2.5 kA / 2.5 kA / 2.5 kA
Type of connection	Pluggable in VSPC BASE
Storage temperature	-40 °C...+80 °C
Ambient temperature (operational)	-40 °C...+70 °C
Protection degree	IP 20
Failure probability	
Ages	43
MTTF	2655
SIL in compliance with IEC 61508	3
Approvals	
Approvals	CE; GOSTME25; OEVE; TUEV; UL
Standards	IEC 61643-21

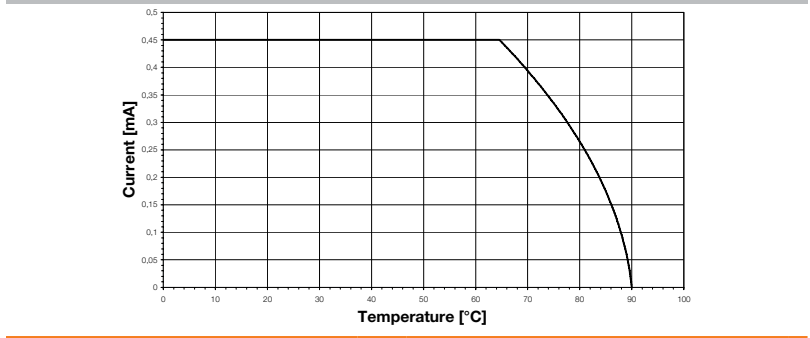
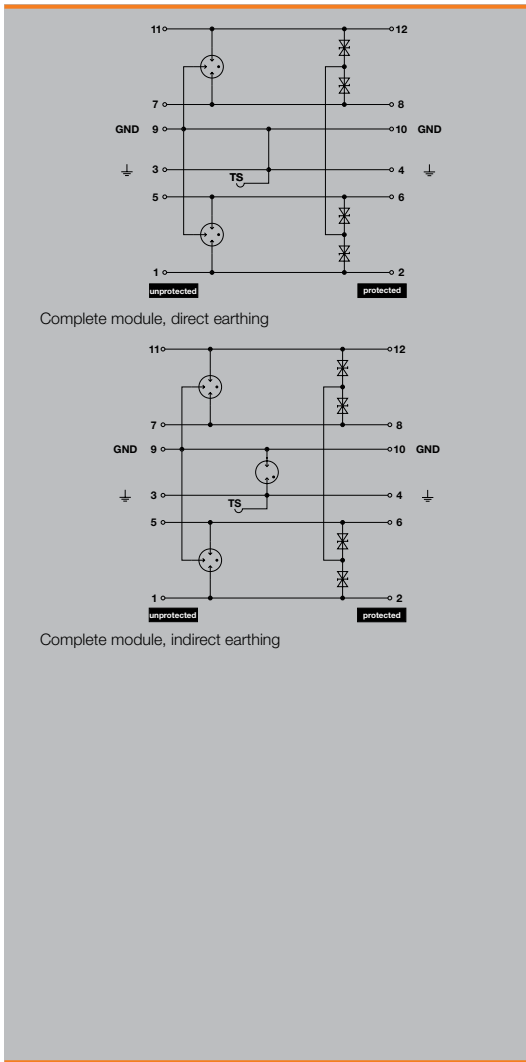

Dimensions of complete module (arrester + base element) no remote sig. contact	
Height x width x depth (mm)	90 / 17.8 / 69
Note	The associated VSPC base element should be ordered with this. The dimension information provided refers to the complete module.

Base elements / base to arresters



Ordering Data (for base)

Description	Type	Qty.	Part No.
Base element, direct earthing	VSPC BASE 2/4CH	1	8924740000
Base element, indirect earthing / floating earth FG	VSPC BASE 2/4CH FG	1	8924300000

Note Technical data can be found on page 106. Order with VSPC CONTROL UNIT.

VSPC 4SL WIRE - arrester / plug-in components



Technical Data

Rated voltage (AC)
 Rated voltage (DC)
 Max. continuous voltage, U_c (AC)
 Max. continuous voltage, U_c (DC)
 Rated current
 Signalling contact
 Optical function display
 Capacitance
 Pulse-reset capacity
 Residual voltage, U_r typical
Protection level
 Wire-wire 1 kV/μs, typically
 Wire-wire 8/20 μs, typically
 Wire-PE 1kV/μs, typically
 Wire-PE 8/20 μs, typically

	VSPC 3/4 WIRE 5 V DC	VSPC 3/4 WIRE 24 V DC
Rated voltage (AC)		
Rated voltage (DC)	3 V	24 V
Max. continuous voltage, U _c (AC)		
Max. continuous voltage, U _c (DC)	6.4 V	28 V
Rated current	450 mA	450 mA
Signalling contact	No	No
Optical function display	No	No
Capacitance	2.3 nF	935 pF
Pulse-reset capacity	≤ 20 ms	≤ 30 ms
Residual voltage, U _r typical	800 V	800 V
Protection level		
Wire-wire 1 kV/μs, typically	35 V	50 V
Wire-wire 8/20 μs, typically	35 V	50 V
Wire-PE 1kV/μs, typically	250 V	270 V
Wire-PE 8/20 μs, typically	800 V	800 V

Ordering Data

No function display		
Type	VSPC 3/4WIRE 5VDC	VSPC 3/4WIRE 24VDC
Part No.	8924540000	8924550000
Qty.	1 ST	1 ST
Note		



VSPC GDT - with sparkover gap (GDT)

- Pluggable arrester (impedance-neutral plugging/unplugging without interruption)
- Can be tested with the V-TEST testing device
- Version with floating-earth PE connection for avoiding voltage potential differences
- Tested in accordance with IEC 61643-21:08
- Integrated PE foot, safely discharges up to 20 kA (8/20 μs) and 2.5 kA (10/350 μs) to PE

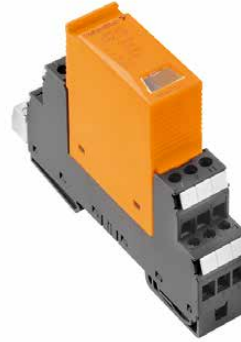

Technical Data

Dielectric strength at FG against PE	≥ 500 V
Volume resistance	0.20 Ω
Overload - failure mode	Modus 2
Requirements category acc. to IEC 61643-21	C1, C2, C3, D1
Surge current-carrying capacity C1	< 1 kA 8/20 μs
Surge current-carrying capacity C2	5 kA 8/20 μs
Surge current-carrying capacity C3	100 A 10/1000 μs
Surge current-carrying capacity D1	2.5 kA 10/350 μs
Discharge current I ₁ (8/20 μs) wire-wire/wire-PE/GND-PE	2 x 2.5 kA / 2.5 kA / 2.5 kA
Discharge I _{max} (8/20 μs) wire-wire/wire-PE/GND-PE	2 x 10 kA / / 10 kA
Lightning test I _{imp} (10/350 μs) wire-wire/wire-PE/GND-PE	2 x 0.2 kA / / 0.2 kA
Type of connection	Pluggable in VSPC BASE
Storage temperature	-40 °C...+80 °C
Ambient temperature (operational)	-40 °C...+70 °C
Protection degree	IP 20
Failure probability	
Ages	11
MTTF	10378
SIL in compliance with IEC 61508	3
Approvals	
Approvals	CE; GOSTME25; TUEV; UL
Standards	According to IEC61643-21

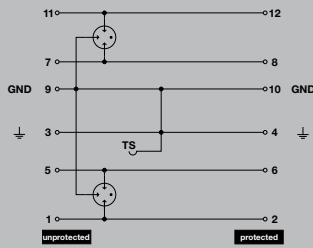

Complete module, direct earthing

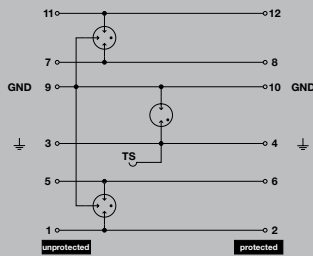

Complete module, indirect earthing

Dimensions of complete module (arrester + base element) no remote sig. contact

Height x width x depth (mm) 90 / 17.8 / 69

Note The associated VSPC base element should be ordered with this. The dimension information provided refers to the complete module.

Base elements / base to arresters



Ordering Data (for base)

Description	Type	Qty.	Part No.
Base element, direct earthing	VSPC BASE 2/4CH	1	8924740000
Base element, indirect earthing / floating earth FG	VSPC BASE 2/4CH FG	1	8924300000

Note Technical data can be found on page 106. Order with VSPC CONTROL UNIT.

VSPC GDT - arrester / plug-in components



Technical Data

	VSPC GDT 2CH 90 V	VSPC GDT 2CH 150 V AC/230 V DC
Rated voltage (AC)	48 V	110 V
Rated voltage (DC)	68 V	150 V
Max. continuous voltage, U _c (AC)	50 V	125 V
Max. continuous voltage, U _c (DC)	72 V	180 V
Rated current	2 A	2 A
Signalling contact	No	No
Optical function display	No	No
Capacitance	9.37 pF	7.45 pF
Residual voltage, U _r typical	1000 V	800 V
Protection level		
Wire-wire 1 kV/μs, typically	650 V	450 V
Wire-wire 8/20 μs, typically	1000 V	800 V
Wire-PE 1kV/μs, typically	650 V	800 V
Wire-PE 8/20 μs, typically	950 V	800 V

Ordering Data

No function display		
Type	VSPC GDT 2CH 90V	VSPC GDT 2CH 150Vac/230Vdc
Part No.	8924570000	8924590000
Qty.	1 ST	1 ST
Note	The 90 V gas discharge tube has a tolerance of +/- 20%.	The 230 V gas discharge tube has a tolerance of +/- 20%.



VSPC MOV - protection with varistor

- Pluggable arrester (impedance-neutral plugging/unplugging without interruption)
- Can be tested with the V-TEST testing device
- Optional monitoring function with status display and alert functions for MOV components
- Version with floating-earth PE connection for avoiding voltage potential differences
- Tested in accordance with IEC 61643-21:08
- Integrated PE foot, safely discharges up to 20 kA (8/20 μs) and 2.5 kA (10/350 μs) to PE

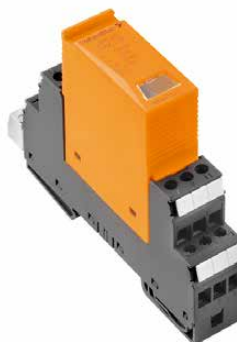

Technical Data

Dielectric strength at FG against PE	≥ 500 V
Volume resistance	0.20 Ω
Overload - failure mode	Mode 1
Requirements category acc. to IEC 61643-21	C1, C2, C3, D1
Surge current-carrying capacity C1	< 1 kA 8/20 μs
Surge current-carrying capacity C2	1.5 kA 8/20 μs
Surge current-carrying capacity C3	100 A 10/1000 μs
Surge current-carrying capacity D1	0.5 kA 10/350 μs
Discharge current I ₁ (8/20 μs) wire-wire/wire-PE/GND-PE	0.2 kA / 2.5 kA / 0.5 kA
Discharge I _{max} (8/20 μs) wire-wire/wire-PE/GND-PE	1.5 kA / / 1.5 kA
Lightning test I _{imp} (10/350 μs) wire-wire/wire-PE/GND-PE	0.2 kA / / 0.5 kA
Type of connection	Pluggable in VSPC BASE
Storage temperature	-40 °C...+80 °C
Ambient temperature (operational)	-40 °C...+70 °C
Protection degree	IP 20
Failure probability	
Ages	26
MTTF	4391
SIL in compliance with IEC 61508	3
Approvals	
Approvals	CE; GOSTME25; OEVE; TUEV; UL
Standards	IEC 61643-21

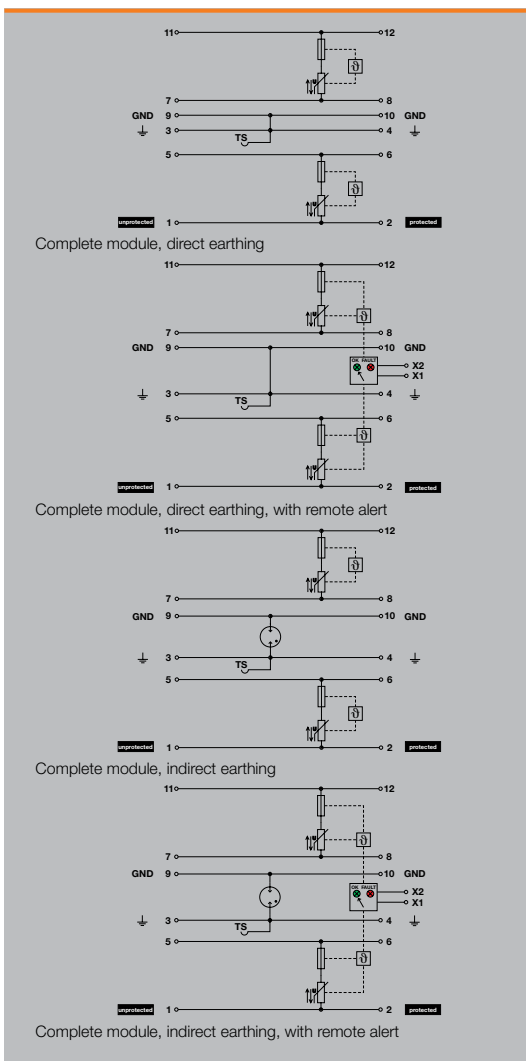

Dimensions of complete module (arrester + base element) no remote sig. contact	
Height x width x depth (mm)	90 / 17.8 / 69
Note	
The associated VSPC base element should be ordered with this. The dimension information provided refers to the complete module.	

Base elements / base to arresters



Ordering Data (for base)

Description	Type	Qty.	Part No.
Base element, indirect earthing with remote contact	VSPC BASE 2/4CH FG R	1	895180000
Base element, direct earthing with remote contact	VSPC BASE 2/4CH R	1	8951790000
Base element, direct earthing	VSPC BASE 2/4CH	1	8924740000
Base element, indirect earthing / floating earth FG	VSPC BASE 2/4CH FG	1	8924300000

Note Technical data can be found on pages 106 and 107. Order with VSPC CONTROL UNIT.

VSPC MOV - arrester / plug-in components



Technical Data

	VSPC MOV 2CH 24 V	VSPC MOV 2CH 230 V	VSPC MOV 2CH 24 V R	VSPC MOV 2CH 230 V R
Rated voltage (AC)	24 V	230 V	24 V	230 V
Rated voltage (DC)	24 V	230 V	24 V	230 V
Max. continuous voltage, U _c (AC)	30 V	275 V	30 V	275 V
Max. continuous voltage, U _c (DC)	38 V	350 V	38 V	350 V
Rated current	10 A	10 A	10 A	10 A
Signalling contact	No	No	U _N 250 V AC 0.1 A 1CO at VSPC R with VSPC CONTROL UNIT	U _N 250 V AC 0.1 A 1CO at VSPC R with VSPC CONTROL UNIT
Optical function display	No	No	green = OK; red = arrester is defective - replace	green = OK; red = arrester is defective - replace
Capacitance	14.5 nF	720 pF	14.5 nF	720 pF
Residual voltage, U _r typical	200 V	850 V	200 V	850 V
Protection level				
Wire-wire 1 kV/μs, typically	80 V	600 V	80 V	600 V
Wire-wire 8/20 μs, typically	95 V	700 V	95 V	700 V
Wire-PE 1kV/μs, typically				
Wire-PE 8/20 μs, typically				

Ordering Data

	Without functional display	Without functional display	With functional display	With functional display
Type	VSPC MOV 2CH 24V	VSPC MOV 2CH 230V	VSPC MOV 2CH 24V R	VSPC MOV 2CH 230V R
Part No.	892460000	892461000	895165000	895166000
Qty.	1 ST	1 ST	1 ST	1 ST
Note				



VSPC TAZ - protection with transport diode

- Pluggable arrester (impedance-neutral plugging/unplugging without interruption)
- Can be tested with the V-TEST testing device
- Optional monitoring function with status display and alert functions for MOV components
- Lower residual voltage
- Version with floating-earth PE connection for avoiding voltage potential differences
- Tested in accordance with IEC 61643-21:08
- Integrated PE foot, safely discharges up to 20 kA (8/20 μs) and 2.5 kA (10/350 μs) to PE

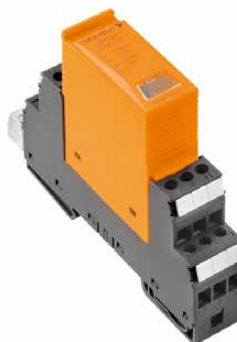

Technical Data

Dielectric strength at FG against PE	≥ 500 V
Volume resistance	0.20 Ω
Overload - failure mode	Mode 1
Requirements category acc. to IEC 61643-21	C3
Surge current-carrying capacity C1	
Surge current-carrying capacity C2	
Surge current-carrying capacity C3	20 A 10/1000 μs
Surge current-carrying capacity D1	
Discharge current I ₁ (8/20 μs) wire-wire/wire-PE/GND-PE	0.05 kA / /
Discharge I _{max} (8/20 μs) wire-wire/wire-PE/GND-PE	0,1 kA / /
Lightning test I _{imp} (10/350 μs) wire-wire/wire-PE/GND-PE	
Type of connection	Pluggable in VSPC BASE
Storage temperature	-40 °C...+80 °C
Ambient temperature (operational)	-40 °C...+70 °C
Protection degree	IP 20
Failure probability	
Ages	32
MTTF	3567
SIL in compliance with IEC 61508	3
Approvals	
Approvals	CE; GOSTME25; OEVE; TUEV; UL
Standards	According to IEC61643-21

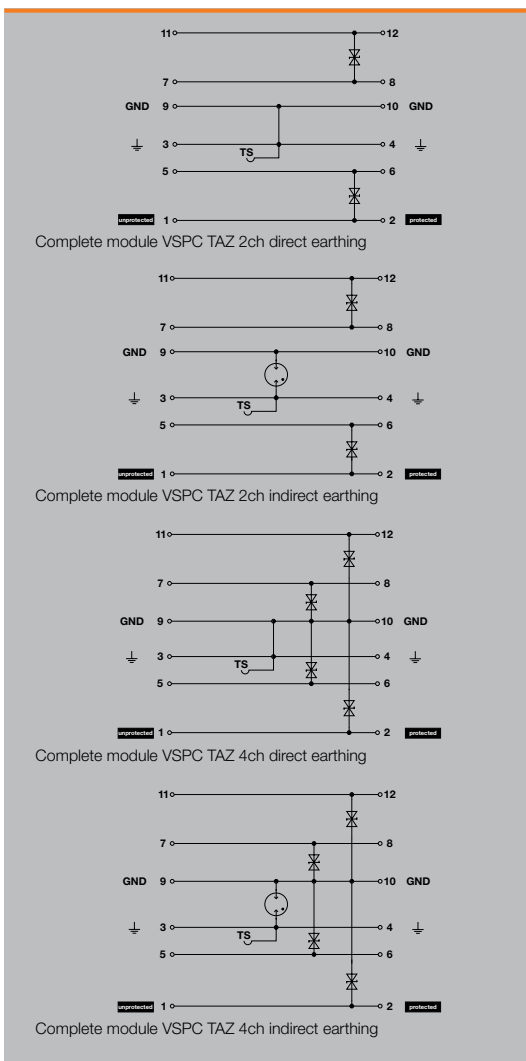

Dimensions of complete module (arrester + base element) no remote sig. contact	
Height x width x depth (mm)	90 / 17.8 / 69
Note	The associated VSPC base element should be ordered with this. The dimension information provided refers to the complete module.

Base elements / base to arresters



Ordering Data (for base)

Description	Type	Qty.	Part No.
Base element, direct earthing	VSPC BASE 2/4CH	1	8924740000
Base element, indirect earthing / floating earth FG	VSPC BASE 2/4CH FG	1	8924300000

Note Technical data can be found on page 106. Order with VSPC CONTROL UNIT.

VSPC TAZ - arrester / plug-in components



Technical Data

Rated voltage (AC)
 Rated voltage (DC)
 Max. continuous voltage, U_c (AC)
 Max. continuous voltage, U_c (DC)
 Rated current
 Signalling contact
 Optical function display
 Capacitance
 Residual voltage, U_r typical

VSPC TAZ 2CH 24 V AC

24 V
 24 V
 28 V
 39 V
 10 A
 No
 No
 387 pF
 65 V

VSPC TAZ 4CH 24 V

24 V
 24 V
 28 V
 39 V
 10 A
 No
 No
 680 pF
 65 V

Protection level

Wire-wire 1 kV/μs, typically
 Wire-wire 8/20 μs, typically
 Wire-PE 1kV/μs, typically
 Wire-PE 8/20 μs, typically

50 V
 55 V
 55 V
 65 V

50 V
 55 V
 55 V
 65 V

Ordering Data

No function display

Type
 Part No.
 Qty.

VSPC TAZ 2CH 24V
8924640000
 1 ST

VSPC TAZ 4CH 24V
8924650000
 1 ST

Note



VSPC TELE UK0 - protection for telephones

- Pluggable arrester (impedance-neutral plugging/unplugging without interruption)
- Can be tested with the V-TEST testing device
- Two-wire input interface - U_{ko}
- Version with floating-earth PE connection for avoiding voltage potential differences
- Tested in accordance with IEC 61643-21:08
- Integrated PE foot, safely discharges up to 20 kA (8/20 μ s) and 2.5 kA (10/350 μ s) to PE

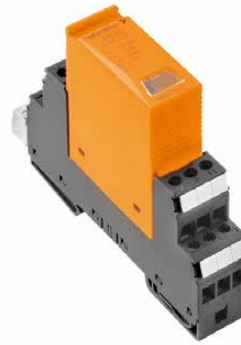

Technical Data

Dielectric strength at FG against PE	≥ 500 V
Volume resistance	2.20 Ω
Overload - failure mode	Modus 2
Requirements category acc. to IEC 61643-21	C1, C2, C3, D1
Surge current-carrying capacity C1	< 1 kA 8/20 μ s
Surge current-carrying capacity C2	5 kA 8/20 μ s
Surge current-carrying capacity C3	100 A 10/1000 μ s
Surge current-carrying capacity D1	2.5 kA 10/350 μ s
Discharge current I_1 (8/20 μ s) wire-wire/wire-PE/GND-PE	2.5 kA / 2.5 kA / 2.5 kA
Discharge I_{max} (8/20 μ s) wire-wire/wire-PE/GND-PE	10 kA / 2 x 10 kA / 10 kA
Lightning test I_{imp} (10/350 μ s) wire-wire/wire-PE/GND-PE	0.2 kA / 2 x 0.2 kA / 0.2 kA
Type of connection	Pluggable in VSPC BASE
Storage temperature	-40 °C...+80 °C
Ambient temperature (operational)	-40 °C...+70 °C
Protection degree	IP 20
Failure probability	
Ages	49
MTTF	2330
SIL in compliance with IEC 61508	3
Approvals	
Approvals	CE; GOSTME25; TUEV; UL
Standards	According to IEC61643-21

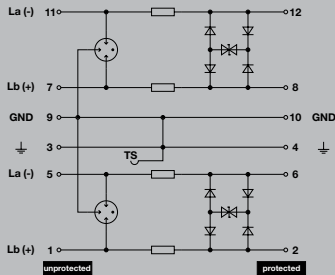

Complete module, direct earthing

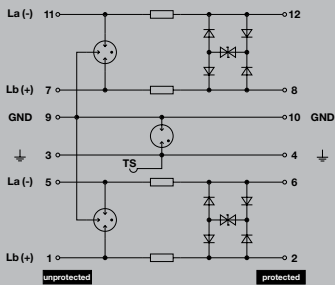

Complete module, indirect earthing

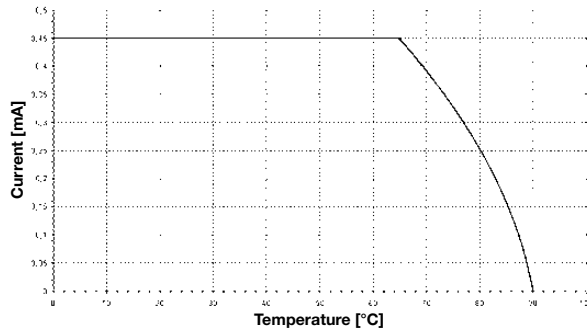

Dimensions of complete module (arrester + base element) no remote sig. contact	
Height x width x depth (mm)	90 / 17.8 / 69
Note	Order the associated VSPC base element with this. The dimension information provided refers to the complete module.

Base elements / base to arresters



Ordering Data (for base)

Description	Type	Qty.	Part No.
Base element, direct earthing	VSPC BASE 2CL	1	8924710000
Base element, indirect earthing / floating earth FG	VSPC BASE 2CL FG	1	8924270000

Note	Technical data can be found on page 106.
-------------	--

VSPC TELE UKO - arrester/plug-in components



Technical Data

Rated voltage (AC)
 Rated voltage (DC)
 Max. continuous voltage, U_c (AC)
 Max. continuous voltage, U_c (DC)
 Rated current
 Signalling contact
 Optical function display
 Input attenuation
 Pulse-reset capacity
 Residual voltage, U_r typical
Protection level
 Wire-wire 1 kV/μs, typically
 Wire-wire 8/20 μs, typically
 Wire-PE 1kV/μs, typically
 Wire-PE 8/20 μs, typically

VSPC TELE UKO 2 WIRE	
Rated voltage (AC)	127 V
Rated voltage (DC)	120 V
Max. continuous voltage, U _c (AC)	130 V
Max. continuous voltage, U _c (DC)	180 V
Rated current	450 mA
Signalling contact	No
Optical function display	No
Input attenuation	101.7 MHz
Pulse-reset capacity	60 ms
Residual voltage, U _r typical	800 V
Protection level	
Wire-wire 1 kV/μs, typically	250 V
Wire-wire 8/20 μs, typically	300 V
Wire-PE 1kV/μs, typically	450 V
Wire-PE 8/20 μs, typically	800 V

Ordering Data

No function display		
Type		VSPC TELE UKO 2WIRE
Part No.		8924660000
Qty.		1 ST
Note		



VSPC RS485 - protection for data signals

- Pluggable arrester (impedance-neutral plugging/unplugging without interruption)
- Can be tested with the V-TEST testing device
- Optional monitoring function with status indicator and alert functions
- Lower residual voltage
- Version with floating-earth PE connection for avoiding voltage potential differences
- Tested in accordance with IEC 61643-21:08
- Integrated PE foot, safely discharges up to 20 kA (8/20 μs) and 2.5 kA (10/350 μs) to PE



Technical Data

Dielectric strength at FG against PE	≥ 500 V
Volume resistance	2.20 Ω
Overload - failure mode	Modus 2
Requirements category acc. to IEC 61643-21	C1, C2, C3, D1
Surge current-carrying capacity C1	< 1 kA 8/20 μs
Surge current-carrying capacity C2	5 kA 8/20 μs
Surge current-carrying capacity C3	100 A 10/1000 μs
Surge current-carrying capacity D1	2.5 kA 10/350 μs
Discharge current I _d (8/20 μs) wire-wire/wire-PE/GND-PE	2.5 kA / 2.5 kA / 2.5 kA
Discharge I _{max} (8/20 μs) wire-wire/wire-PE/GND-PE	10 kA / 2 x 10 kA / 10 kA
Lightning test I _{imp} (10/350 μs) wire-wire/wire-PE/GND-PE	0.2 kA / 2 x 0.2 kA / 0.2 kA
Type of connection	Pluggable in VSPC BASE
Storage temperature	-40 °C...+80 °C
Ambient temperature (operational)	-40 °C...+70 °C
Protection degree	IP 20
Failure probability	
Ages	57
MTTF	2003
SIL in compliance with IEC 61508	3
Approvals	
Approvals	CE; GOSTME25; OEVE; TUEV; UL
Standards	IEC 61643-21

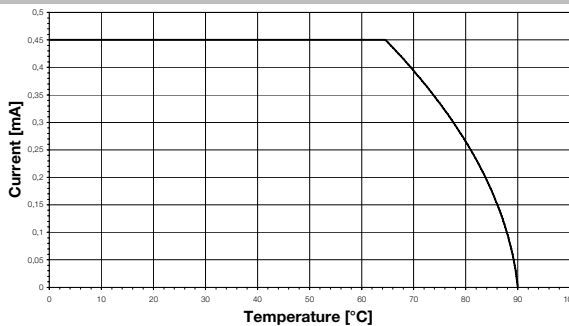
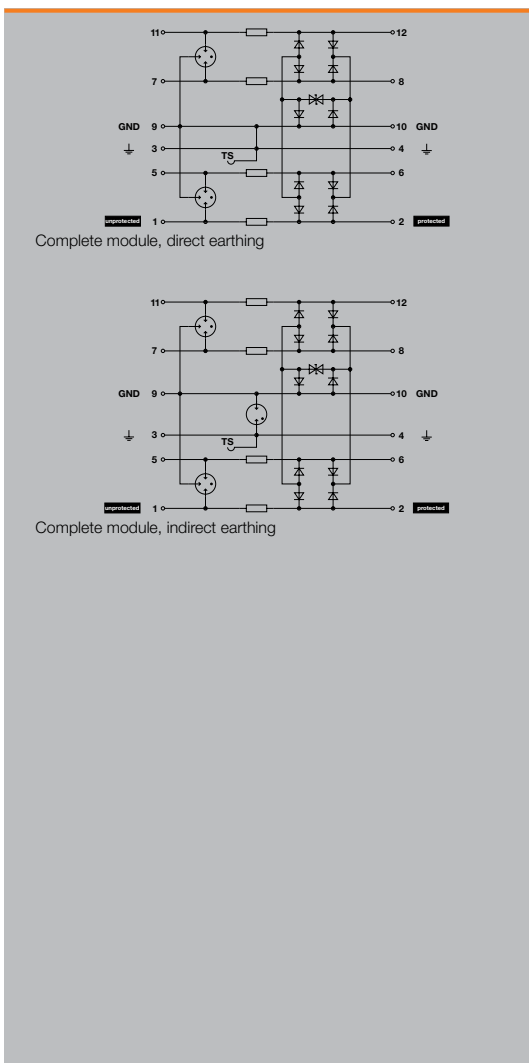

Dimensions of complete module (arrester + base element) no remote sig. contact

Height x width x depth (mm) 90 / 17.8 / 69

Note The associated VSPC base element should be ordered with this. The dimension information provided refers to the complete module.

Base elements / base to arresters



Ordering Data (for base)

Description	Type	Qty.	Part No.
Base element, direct earthing	VSPC BASE 2CL	1	8924710000
Base element, indirect earthing / floating earth FG	VSPC BASE 2CL FG	1	8924270000

Note Technical data can be found on page 106.

VSPC RS485 - arrester / plug-in components



Technical Data

Rated voltage (AC)
 Rated voltage (DC)
 Max. continuous voltage, U_c (AC)
 Max. continuous voltage, U_c (DC)
 Rated current
 Input attenuation
 Pulse-reset capacity
 Residual voltage, U_p, typical

VSPC RS485 2CH

	5 V
	6.4 V
	450 mA
	113.6 MHz
	≤ 20 ms
	35 V

Protection level

Wire-wire 1 kV/μs, typically
 Wire-wire 8/20 μs, typically
 Wire-PE 1kV/μs, typically
 Wire-PE 8/20 μs, typically

	10 V
	15 V
	10 V
	35 V

Ordering Data

No function display

Type
 Part No.
 Qty.

VSPC RS485 2CH

8924670000

1 ST

Note



VSPC RS485 - protection for data signals with remote alert

- Pluggable arrester (impedance-neutral plugging/unplugging without interruption)
- Can be tested with the V-TEST testing device
- Optional monitoring function with status indicator and alert functions
- Lower residual voltage
- Version with floating-earth PE connection for avoiding voltage potential differences
- Tested in accordance with IEC 61643-21:08
- Integrated PE foot, safely discharges up to 20 kA (8/20 μs) and 2.5 kA (10/350 μs) to PE

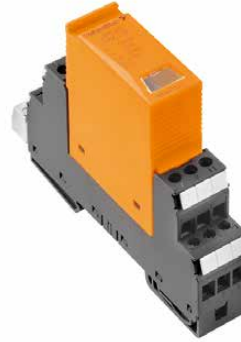

Technical Data

Dielectric strength at FG against PE	≥ 500 V
Volume resistance	2.20 Ω
Overload - failure mode	Modus 2
Requirements category acc. to IEC 61643-21	C1, C2, C3, D1
Surge current-carrying capacity C1	< 1 kA 8/20 μs
Surge current-carrying capacity C2	5 kA 8/20 μs
Surge current-carrying capacity C3	100 A 10/1000 μs
Surge current-carrying capacity D1	2.5 kA 10/350 μs
Discharge current I _d (8/20 μs) wire-wire/wire-PE/GND-PE	2.5 kA / 2.5 kA / 2.5 kA
Discharge I _{max} (8/20 μs) wire-wire/wire-PE/GND-PE	10 kA / 2 x 10 kA / 10 kA
Lightning test I _{imp} (10/350 μs) wire-wire/wire-PE/GND-PE	0.2 kA / 2 x 0.2 kA / 0.2 kA
Type of connection	Pluggable in VSPC BASE
Storage temperature	-40 °C...+80 °C
Ambient temperature (operational)	-40 °C...+70 °C
Protection degree	IP 20
Failure probability	
Ages	90
MTTF	1266
SIL in compliance with IEC 61508	3
Approvals	
Approvals	CE; GOSTME25; OEVE; TUEV; UL
Standards	IEC 61643-21

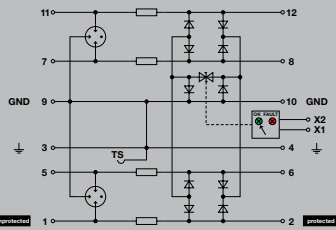

Complete module, direct earthing, with remote alert

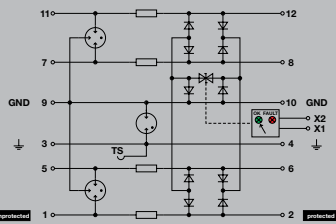

Complete module, indirect earthing, with remote alert

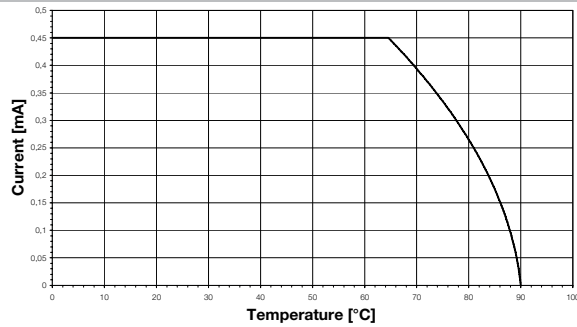

Dimensions of complete module (arrester + base element) with remote signalling (R)

Height x width x depth (mm) 98 / 17.8 / 69

Note The associated VSPC base element should be ordered with this. The dimension information provided refers to the complete module.

Base elements / base to arresters



Ordering Data (for base)

Description	Type	Qty.	Part No.
Base element, indirect earthing with remote contact	VSPC BASE 2/4CH FG R	1	895180000
Base element, direct earthing with remote contact	VSPC BASE 2/4CH R	1	8951790000

Note Technical data can be found on page 107. Order with VSPC CONTROL UNIT.

VSPC RS485 - arrester / plug-in components with remote alert



Technical Data

VSPC RS485 2CH R	
Rated voltage (AC)	
Rated voltage (DC)	5 V
Max. continuous voltage, U_c (AC)	
Max. continuous voltage, U_c (DC)	6.4 V
Rated current	450 mA
Signalling contact	U_N 250 V AC 0.1 A 1CO at VSPC R with VSPC CONTROL UNIT
Optical function display	green = OK; red = arrester is defective - replace
Input attenuation	113.6 MHz
Pulse-reset capacity	≤ 20 ms
Residual voltage, U_p , typical	35 V
Protection level	
Wire-wire 1 kV/ μ s, typically	10 V
Wire-wire 8/20 μ s, typically	15 V
Wire-PE 1 kV/ μ s, typically	10 V
Wire-PE 8/20 μ s, typically	35 V

Ordering Data

With functional display	
Type	VSPC RS485 2CH R
Part No.	895 1670000
Qty.	1 ST
Note	



Direct earthing

Base element

Base element with FG

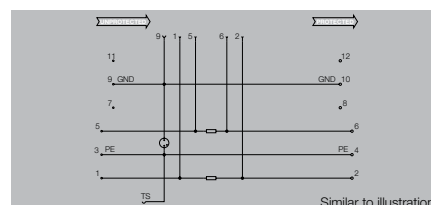
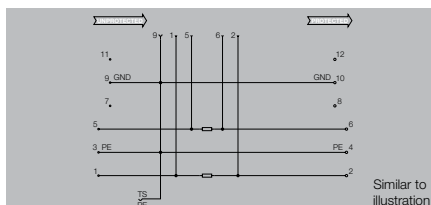

Technical Data

Stripping length, rated connection	7 mm
Wire cross-section, stranded, min.	0.5 mm ²
Wire cross-section, stranded, max.	2.5 mm ²
Wire cross-section, solid, min.	0.5 mm ²
Wire cross-section, solid, max.	4 mm ²
Clamping range, rated connection, min.	0.5 mm ²
Clamping range, rated connection, max.	4 mm ²
Tightening torque, min.	0.5 Nm
Tightening torque, max.	0.8 Nm
Type of connection	Screw connection
Certificate No. (UL)	E311081VOL1SEC2
Approvals	CE; GOSTME25; UL
Ambient temperature (operational)	-40 °C...+70 °C
Storage temperature	-40 °C...+80 °C
UL 94 flammability rating	V-0
Pollution severity	2
Surge voltage category	III

Stripping length, rated connection	7 mm
Wire cross-section, stranded, min.	0.5 mm ²
Wire cross-section, stranded, max.	2.5 mm ²
Wire cross-section, solid, min.	0.5 mm ²
Wire cross-section, solid, max.	4 mm ²
Clamping range, rated connection, min.	0.5 mm ²
Clamping range, rated connection, max.	4 mm ²
Tightening torque, min.	0.5 Nm
Tightening torque, max.	0.8 Nm
Type of connection	Screw connection
Certificate No. (UL)	E311081VOL1SEC2
Approvals	CE; GOSTME25; UL
Ambient temperature (operational)	-40 °C...+70 °C
Storage temperature	-40 °C...+80 °C
UL 94 flammability rating	V-0
Pollution severity	2
Surge voltage category	III

Stripping length, rated connection	7 mm
Wire cross-section, stranded, min.	0.5 mm ²
Wire cross-section, stranded, max.	2.5 mm ²
Wire cross-section, solid, min.	0.5 mm ²
Wire cross-section, solid, max.	4 mm ²
Clamping range, rated connection, min.	0.5 mm ²
Clamping range, rated connection, max.	4 mm ²
Tightening torque, min.	0.5 Nm
Tightening torque, max.	0.8 Nm
Type of connection	Screw connection
Certificate No. (UL)	E311081VOL1SEC2
Approvals	CE; GOSTME25; UL
Ambient temperature (operational)	-40 °C...+70 °C
Storage temperature	-40 °C...+80 °C
UL 94 flammability rating	V-0
Pollution severity	2
Surge voltage category	III

Dimensions	
Height x width (mm)	90 / 17.8

Dimensions	
Height x width (mm)	90 / 17.8

Dimensions	
Height x width (mm)	90 / 17.8

Note

Note

Note

Ordering Data

No remote sig. contact

Type	Qty.	Part No.
VSPC BASE 1CL	1	8924730000
VSPC BASE 2SL	1	8924720000
VSPC BASE 2CL	1	8924710000
VSPC BASE 2/4CH	1	8924740000
VSPC BASE 1CL PW	1	1070230000
VSPC BASE 4SL	1	8924700000

Type	Qty.	Part No.
VSPC BASE 1CL FG	1	8924290000
VSPC BASE 2SL FG	1	8924280000
VSPC BASE 2CL FG	1	8924270000
VSPC BASE 1CL PW FG	1	1105700000
VSPC BASE 2/4CH FG	1	8924300000
VSPC BASE 4SL FG	1	8924260000

Note

Note

Note

Accessories

Note

EMC Set: 1067470000 Marker: DEK 5

EMC Set: 1067470000 Marker: DEK 5

Direct earthing, with remote alert

Base element

Base element with FG

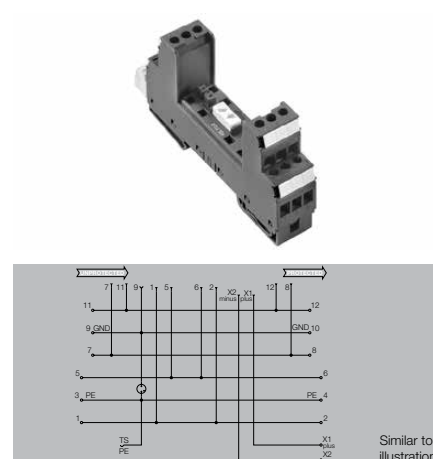
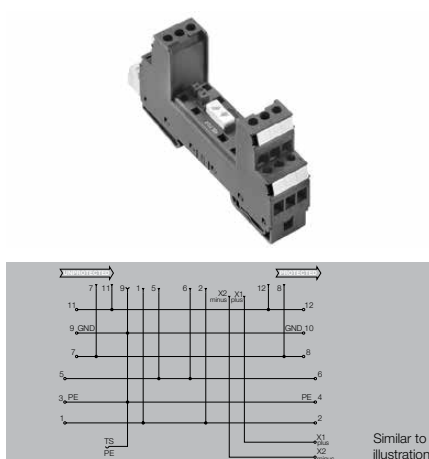

Technical Data

Stripping length, rated connection
Wire cross-section, stranded, min.
Wire cross-section, stranded, max.
Wire cross-section, solid, min.
Wire cross-section, solid, max.
Clamping range, rated connection, min.
Clamping range, rated connection, max.
Tightening torque, min.
Tightening torque, max.
Type of connection
Certificate No. (UL)
Approvals
Ambient temperature (operational)
Storage temperature
UL 94 flammability rating
Pollution severity
Surge voltage category

7 mm
0.5 mm ²
2.5 mm ²
0.5 mm ²
4 mm ²
0.5 mm ²
4 mm ²
0.5 Nm
0.8 Nm
Screw connection
E31 1081VOL1SEC2
CE: GOSTME25; UL
-40 °C...+70 °C
-40 °C...+80 °C
V-0
2
III

7 mm
0.5 mm ²
2.5 mm ²
0.5 mm ²
4 mm ²
0.5 mm ²
4 mm ²
0.5 Nm
0.8 Nm
Screw connection
E31 1081VOL1SEC2
CE: GOSTME25; UL
-40 °C...+70 °C
-40 °C...+80 °C
V-0
2
III

Dimensions
Height x width (mm)

98 / 17.8

98 / 17.8

Note

--

--

Ordering Data

With remote sig. contact (R)

Type	Qty.	Part No.
VSPC BASE 2SL R	1	8951770000
VSPC BASE 1CL R	1	8951730000
VSPC BASE 2CL R	1	8951710000
VSPC BASE 2/4CH R	1	8951790000
VSPC BASE 4SL R	1	8951750000

Type	Qty.	Part No.
VSPC BASE 2SL FG R	1	8951780000
VSPC BASE 1CL FG R	1	8951740000
VSPC BASE 2CL FG R	1	8951720000
VSPC BASE 2/4CH FG R	1	8951800000
VSPC BASE 4SL FG R	1	8951760000

Note

--

--

Accessories

Note

EMC Set: 1067470000 Marker: DEK 5

EMC Set: 1067470000 Marker: DEK 5

VSPC accessories

V-Ground

- Can be applied to unassigned wires
- Usable during start-up and maintenance
- Earthing of all sensor cables
- Can be plugged into standard base sockets

V-Test-Connector

- Usable during start-up and maintenance
- For circuit voltage measurements using a standard 2.3-mm test socket
- Can be plugged into standard base sockets



Technical Data

Rated voltage (DC)	230 V AC
Max. continuous voltage, U _c (DC)	255 V AC
Rated current	< 0.5 A
Volume resistivity per path	< 0.2 Ω
Type of connection	Pluggable in VSPC BASE
Storage temperature	-40 °C...+80 °C
Ambient temperature (operational)	-40 °C...+70 °C
Rel. humidity	5 %...96 % RH
Degree of protection	IP 20

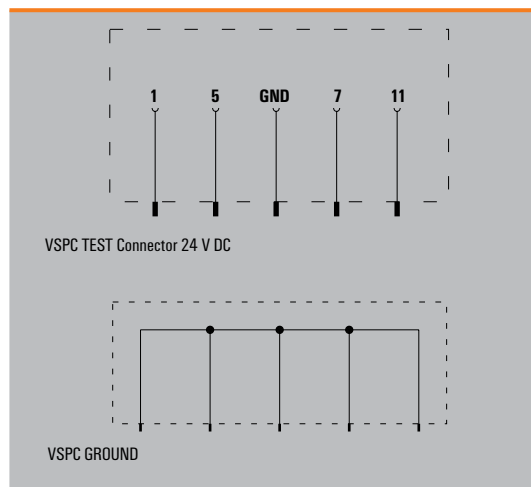

Note

Ordering Data

Arrester / plug-in elements

Note

Type	Qty.	Part No.
VSPC TEST Connector 24DC	1	8924690000
VSPC GROUND	1	8924680000



Ordering Data

Shield connection:	Complete set - cable ties and shield connection
	Cable ties
	Shield connection
	Cable tie tool

Type	Qty.	Part No.
EMC-set	1	1067470000
EMC-tie	100	1067490000
EMC-connector	50	1067520000
Cable tie tool RT-1	1	1296000000

The interlock mechanism on the VSPC Series pluggable arresters delivers extra reliability and an improved permanent contact under strong vibrating conditions.

VSPC Locking Clip

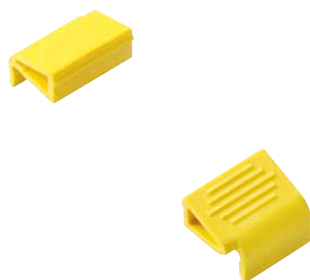

Technical Data

Color
Marking
Function
Weight
Note

yellow
Individually with a label
Removal with screwdriver
Snap-on by hand (press on)
10 g
Note

Ordering Data

Note

Type	Qty.	Part No.
VSPC LOCKING CLIP	100	1317340000
Note		

Cross-connection (QB) between the VSPC signal contacts can be installed quickly. Cross-connections can be individually separated for the alert function, with maximum of 10 VSPC R.

QB 17.8/2



Technical Data

Version
Dimensions (L x W x H)
Pitch
Rated current
Cross-section
Weight
Color
Note

2-pole with 9 QBs together = 1 strip
9 mm (15.5 mm with contact) x 6 mm x 21 mm (9 QBs = 160.7 mm)
17.8 mm
17.5 A
1.5 mm ²
12.4 g/QB
yellow
Note

Ordering Data

Note

Type	Qty.	Part No.
QB 17.8/2	10 strips, with 9 QBs each	1309470000
Note		

VSPC CONTROL UNIT 24 V DC

- For monitoring up to 10 protective modules
- Signalling module for all VSPCs with status indicator
- Signalling of cable breaks / signal interruptions
- Voltage supply from 18...31 V DC
- Potential-free changeover contact
- Function indicator (red/green LED)
- Other NC-contact monitoring functions can be integrated into the signal circuit (e.g. PU I, PU II and PU III)



Technical Data

Input	
Rated voltage (DC)	18 V...24 V DC...31 V DC
Rated current	max. 50 mA
Power rating	1.5 W
Output	
Current loop	8 mA at < 51 V
Monitoring option	1...10 VSPC modules
Signal output	
Type	1 CO contact
Max. switching voltage / continuous current	250 V / 1 A
Diagnostics	
Operating status	Green LED
Defect at current loop	Red LED (control unit and defective module)
Wire breakage	Red/green LED, flashing
General data	
Terminal rail	TS 35
Design, Protection class	Insta-enclosure, IP 20
Type of connection	BL / SL
Storage temperature	-40 °C...+80 °C
Ambient temperature (operational)	-40 °C...+70 °C
Rel. humidity	5%...96% RH
Start-up time after fault correction	60 s

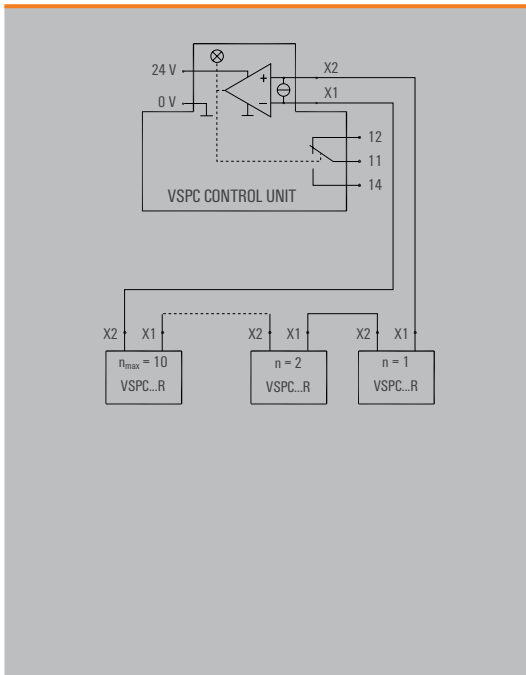

Dimensions	
Dimensions incl. enclosure H x W x D (mm)	102 x 18 x 71.5
Note	

Application

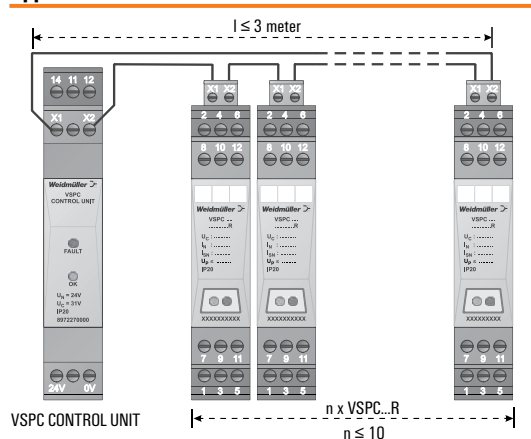

Status indication

LED green	LED red	Function	
		OK	✓
		Error (one or more VSPC ... R are defective)	
		Line break in the monitoring circuit; arrester pulled out or plug not in base	

Ordering Data

Type	Qty.	Part No.
VSPC CONTROL UNIT 24Vdc	1 piece	8972270000
Note		



V-TEST

Testing device from the VARITECTOR Series

A testing device for pluggable surge protection: for testing in compliance with the IEC 62305-3 standard

The V-TEST is a compact, easily carried, testing device for pluggable protection modules from the VARITECTOR SPC family. The testing device can be used to test the protective function of the overvoltage protection components in accordance with the test intervals required in IEC 62305-3. It provides information regarding the functional status of the protective components.

The backlit display shows the measured reading per component (GDT, MOV, TAZ) as "OK" or "not OK". This function allows you to detect ageing components as it highlights possible damage right away. Thus total protection is guaranteed.

The V-TEST is equipped with a charger and a battery set which allows autonomous use in the field. A comfortable and protective carry bag is delivered free with the tester.



Always delivers precise readings

The V-TEST self-calibrates when it is turned on, ensuring that it can always deliver precise measurement and test values.



Portable

The compact device comes with an integrated rechargeable battery and protective case – making it perfect for use in the field.





Ensures timely testing intervals

The portable V-TEST can be used to carry out repeated testing in compliance with IEC 62305-3.

Lightning protection level (LPL)	Interval for complete testing	Interval for visual inspection
I	2 years	1 year
II	4 years	2 years
III/IV	6 years	3 years

Quick and easy to operate

It only takes a few simple menu steps (in German or English) to navigate directly to the measurement function.

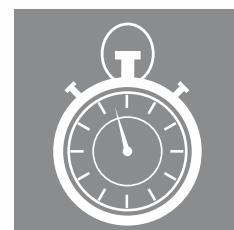

V-TEST

VSPC accessories

V-TEST

- Instrument for testing the protective functions of series: PUI, PU II and VSPC
- Device for realising standard IEC 62305 (periodic testing)
- Handy device with integrated battery set for local measurements
- Result display via LCD display
- Bilingual menu
- Including protective bag and power supply
- Intuitive user navigation in German and English

The V-TEST is a compact, portable instrument for the Varitector SPC pluggable surge protection (VSPC series) and surge protection for power distribution, PUI and II series. With this instrument, Weidmüller surge protection solutions can be tested for protective function in accordance with the required test periods as stipulated by IEC62305 (DIN VDE 185 Part 3). In a backlit display, the measurement result is indicated with "OK" or "not OK" for each component.



Technical Data

Rated voltage	100...240 V AC
Accumulator set	8 NiMH with 2600 mA
Storage temperature	0 °C ... 40 °C
Ambient temperature (operational)	0 °C ... 40 °C
Degree of protection	IP 20
Measuring range	U < 1000 V / I = 1 mA
UL94 flammability class	V0

General tolerances of measurement range

Gas discharge tube	+/- 10%
Varistor	+/- 5%
TVS-diode	+/- 5%

Dimensions

Height x Width x Depth (mm)	230 x 122 x 65
-----------------------------	----------------

Note

Ordering Data

Type	Qty.	Part No.
V-TEST	1	8951860000

Note

VARITECTOR SSC

Surge protection in a terminal block: for measurement and control systems

VARITECTOR SSC

Weidmüller's VARITECTOR SSC series for surge protection (VSSC4 and VSSC6) is well suited for protecting measurement and control circuits. It features good protective functionality in a compact terminal-block design. This is due to its 6.2 mm width. The combined Torx®/ slotted screw ensures that the proper nominal or max. torque is applied to the connection. The required screwdrivers are available from Weidmüller under the following order numbers:

4-mm slotted SD 0.8 x 4.0 x 100 (**part no. 9008340000**) or T15 Torx® (**part no. 9009170000**). The VSSC can be snapped on, to directly earth it to the DIN-rail. The VSSC series is available with four clamping yokes (VSSC4) and six clamping yokes (VSSC6). The screw terminal has a nominal torque of 0.5 Nm, but it can be tightened to 0.8 Nm. The VARITECTOR SSC series is optimally designed for compact installation locations in process automation, industrial automation or building automation.

The two-stage surge protection terminals are equipped with gas discharge tubes (GDT), suppressor diodes (TVS) and decoupling components. Individual protective components (such as gas-filled spark gaps, varistors and suppressor diodes) supplement this product line. Our VARITECTOR SSC surge protectors are available for components with nominal voltages of 12 V, 24 V, 48 V to 230 V. Please contact us for other voltages or special applications.

The two-stage surge protection terminals are equipped with gas discharge tubes (GDT), suppressor diodes (TVS) and decoupling components. Individual protective

components (such as gas-filled spark gaps, varistors and suppressor diodes) supplement this product line. Our VARITECTOR SSC surge protectors are available for components with nominal voltages of 12 V, 24 V, 48 V to 230 V. Please contact us for other voltages or special applications. The PE contact is established by snapping onto an earthed DIN-rail. The TS 35 must be earthed in order to ensure safe power discharging via the terminals of up to 20 kA (8/20 μ s) and 2.5 kA (10/350 μ s). The DIN-rail must be screwed onto the earthed mounting plate to ensure EMC. The best protection is achieved when a PE contact is established every 60 cm / 24 inch using the terminal at the VARITECTOR SSC terminals with direct equipotential bonding. The cable should correspond to the max. cross-section of the VSSC connection. The four-port VARITECTOR SSC terminal can be used for binary and / or analog signal circuits. The six-port VARITECTOR SSC can also be used to open signal circuits via an isolated level and monitor them using the optional built-in LED.

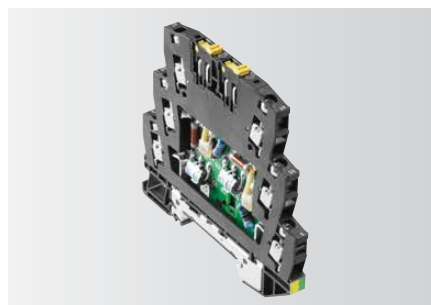

VARITECTOR SSC6

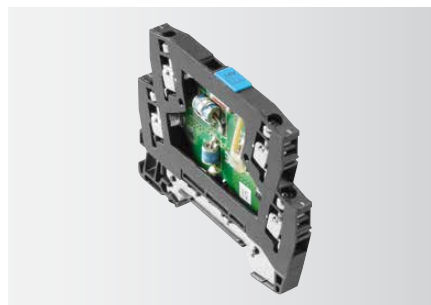

VARITECTOR SSC4

Overview of model types

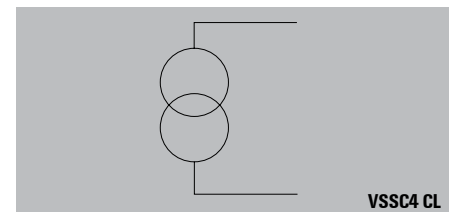

The **VSSC4 CL** is a two-stage protective combination that has a suppressor diode between the current paths. This VSSC4 CL limits the surge voltage in **an analog signal circuit** (e.g. a current loop).

The **VSSC4 CL FG** is a two-stage protective combination that has a suppressor diode between the current paths. The gas discharge tube to the PE provides a high-resistance earthing for the protective circuitry. Thus the current loop can be operated with a floating ground. This VSSC4 CL FG limits the surge voltage in **an analog unearthed signal circuit** (e.g. a current loop).

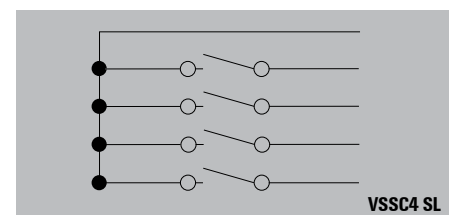

The basic principle of a binary current circuit

The **VSSC4 SL** is a two-stage protective combination with a suppressor diode for each stage from the current path to PE. This **VSSC4 SL** limits the surge voltage in **an earthed binary signal** (e.g. for alert contacts). The VSSC4 SL FG is used for **non-earthed signal circuits**.

VARITECTOR SSC

The **VSSC4 SL FG** is a two-stage protective combination with a suppressor between the current paths and common return wire. The gas discharge tube to the PE provides a high-resistance earthing for the protective circuitry. Thus the protective circuitry can be operated with a floating earth. This VSSC4 SL FG limits the surge voltage in a **binary floating signal circuit**.

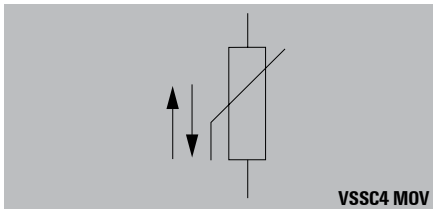

The **VSSC4 MOV** provides one-stage protection with a varistor (MOV) for the current path to PE. This **VSSC4 MOV** limits the surge voltage in a **circuit** (e.g. for solenoid valves). The thermally monitored MOV is available in voltages of 12 V, 24 V, 48 V, 60 V, 120 V, 150 V and 240 V.

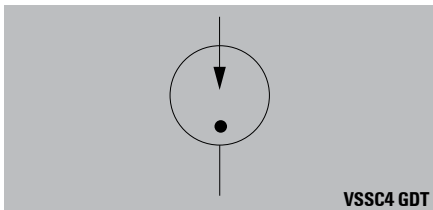

The **VSSC4 GDT** provides one-stage protection with a gas discharge tube (GDT) for the current path to PE. This **VSSC4 GDT** limits the surge voltage in a **circuit**. This terminal is used where no leakage current is permitted to flow to the earth, or where a high-impedance cable shield is connected to the earth. The GDT is available in voltages of 90 V, 110 V and 240 V.

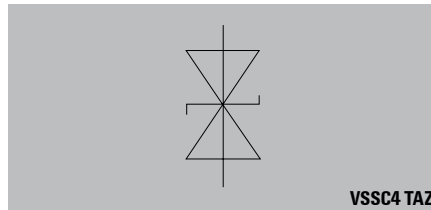

The **VSSC4 TAZ** provides one-stage protection with a quick-response (<10 ps) suppressor diode (TAZ) for the current path to PE. This **VSSC4 TAZ** limits the surge voltage in a **circuit** (e.g. for digital inputs). The TAZ is available in voltages of 12 V, 24 V, 48 V and 60 V.

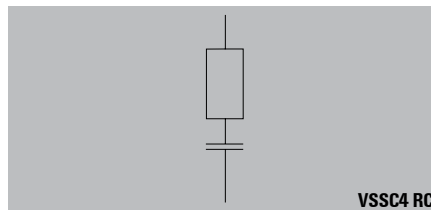

VSSC4 RC is the final protective variant in the VSSC series. This variant combines a thermally monitored varistor and an RC combination. It can be used for spark suppression on inductive loads. The VSSC4 RC is available in 24 V and 240 V.

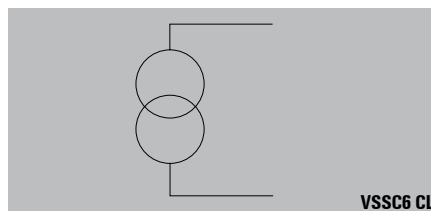

The **VSSC6 CL** is a two-stage protective combination that has a suppressor diode between the current paths. This VSSC6 CL limits the surge voltage in an **analog signal circuit** (e.g. a current loop). The PE potential can be provided on terminal point 3/6 by snapping the terminal on an earthed DIN-rail. This allows a shield connection to be connected. This version is also available as the **VSSC6 CL FG** floating-ground protective circuit.

The **VSSC6 TR CL** is built like the VSSC6 CL and also has two isolators. The 2.3-mm PS 2.3 (**part no. 018040000**) can be plugged into the Torx® screw head. The isolation makes it possible to take measurements in the field, in the electrical cabinet or via the surge protection. This version is also available as the **VSSC6 TR CL FG** floating-ground protective circuit.

The **VSSC6 SL LD** is a two-stage protective combination with a suppressor between the current paths and common return wire. This VSSC6 SL limits the surge voltage in **two binary signal circuits**. The signal status for each signal circuit is indicated by an LED.

The **VSSC6 TR SL LD** is built like the VSSC6 L LD but also has two isolators. The 2.3-mm plug uses the screws to provide easy signal measurements. This version is also available as the **VSSC6 TR SL FG** floating-ground protective circuit.

The **VSSC6 MOV** provides one-stage protection with two thermally monitored varistors (MOV) between the current paths and common return wire. This VSSC6 MOV limits the surge voltage in **two binary signal circuits**.

The **VSSC6 TR LD MOV** provides one-stage protection with two thermally monitored varistors (MOV) between the current paths and common return wire. The VSSC6 MOV limits the surge voltage in **two binary signal circuits** and also has an isolator and an LED for each signal circuit.

The **VSSC6 GDT** provides one-stage protection with two gas discharge tubes (GDT) between the current paths and common return wire. This VSSC6 GDT limits the surge voltage in **two binary signal circuits**.

The **VSSC6 TR LD GDT** provides two-stage protection with two gas discharge tubes (GDT) between the current paths and common return wire. The VSSC6 GDT limits the surge voltage in **two binary signal circuits** and also has an isolator for each signal circuit.

The **VSSC6 TAZ** provides one-stage protection with two suppressor diodes (TAZ) between the current paths and common return wire. The VSSC6 TAZ limits the surge voltage in **two binary signal circuits** and also has an isolator and an LED for each signal circuit.

The **VSSC6 TR LD TAZ** provides one-stage protection with two suppressor diodes (TAZ) between the current paths and common return wire. The VSSC6 TAZ limits the surge voltage in **two binary signal circuits** and also has an isolator and an LED for each signal circuit.

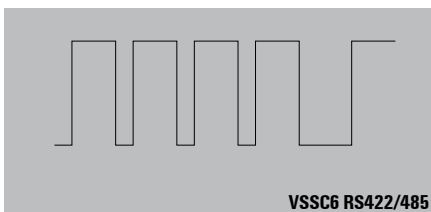

The **VSSC6 RS485** is a two-stage protective combination that has suppressor diodes between the current paths. This VSSC6 RS485 limits the surge voltage in **two high-frequency signal circuits** with common return wires. The VSSC RS485 is available in the PROFIBUS PA and DP variants.

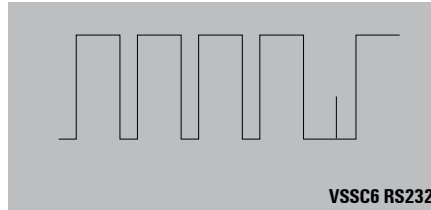

The **VSSC6 RS232** is a two-stage protective combination that has suppressor diodes between the current paths. This VSSC6 RS232 limits the surge voltage in **a signal circuit**.

Black Material PA6.6 with UL94 V0 is used for the VSSC4 and VSSC6 series so that they are suitable for use in many applications. They are suitable for use in temperatures ranging from -40 to +70 °C.

Discharge capacity

Tested in compliance with standard IEC 61643-21 for providing surge protection in signalling networks with voltage and current pulses. The VSSC series has been tested to comply with IEC 61643-21 and EN 61643-21. Modules were tested with categories C1, C2 and C3: with quick-rising edges with up to 300 pulses. Category D1 describes high-power testing (10/350 µs), so that the VSSC series can be used in compliance with IEC 62305-4. The VSSC is color-coded so that it is easy to detect the voltage level (or the signal location SL or CL).

Color coding

Voltage level	Color
≤ 12 V	green
24 V Binary	blue
24 V Analog	yellow
48 V	red
≥ 60 V	violet
Special function	white

Installation

The VSSC series is used to protect signal circuits. In order to achieve a complete protective strategy for the facility, the power feed must be protected with Type II surge protection (for example, by using the VPU II series).

For existing lightning protection facilities, Type I protection must be used (for example, by using the VPU I series). Type II protection (for example, the VPU II) is sufficient when there is no lightning protection facility.

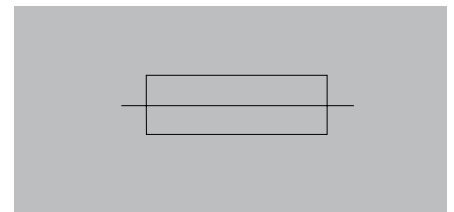

Fusing

The VSPC surge protection modules are designed so that they are decoupled between the individual protective stages. When relying on an external fuse, make sure to maintain the following:

- Maximum nominal current
- Derating curve
- Type of installation
- Application

Category

**IEC 61643-21
C1, C2, C3, D1**

VARITECTOR SSC

Category	Testing pulse	Surge voltage	Surge current	Pulse	Type
C1	Quick rising edge	0.5 < 2 kV with 1.2/50 µs	0.25 < 1 kA with 8/20 µs	300	Surge voltage arrester
C2	Quick rising edge	2 < 10 kV with 1.2/50 µs	1 < 5 kA with 8/20 µs	10	Surge voltage arrester
C3	Quick rising edge	≥ 1 kV with 1 kV/µs	10 < 100 A with 10/10.000 µs	300	Surge voltage arrester
D1	High power	≥ 1 kV	0.5 < 2.5 kA with 10/350 µs	2	Arrester for lightning current and surge voltages

Category C reflects the interference pulses with quick-rising edges and minimised power. Category D uses quick-rising edges and high power to detail the interference pulses. This energy simulates the high-power load that stems from coupled partial lightning currents.

General technical data

Storage temperature: -40 °C ... +80 °C
 Operating temperature: -40 °C ... +70 °C
 Humidity: 5 % ... 96 % 5 %...96 %
 RH without condensation
 Material: VO, IP 20

Connection: VSSC4 and VSSC6
 Torx®: T15 900917
 Slotted: 0.8 x 4
 (order number 9008340000)
 Nominal torque: 0.5 Nm
 Max. Drehmoment: 1 Nm
 Max. torque: 10 mm
 Solid core: 0.5...6 mm²
 Stranded: 0.5 ... 4 mm²
 Finely stranded: 0.5 4 mm²
 Finely stranded with ferrule: 0.5 4 mm²

Dimensions

VSSC4:
 Width: 6.1 mm
 Width with frame: 12.2 mm
 Height: 76 mm
 Depth: 58.5 mm with TS 35 x 7.5

Top connections:
 Unprotected: 1
 Protected: 4
 Bottom connections:
 Unprotected: 2
 Protected: 3

VSSC6:
 Width: 6.1 mm
 Width with frame: 12.2 mm
 Height: 88.5 mm
 Depth: 81 mm with TS 35 x 7.5

Top connections:
 Unprotected: 1
 Protected: 4
 Mid-level connections:
 Unprotected: 2
 Protected: 5
 Bottom connections:
 Unprotected: 3
 Protected: 6

Markers for VSSC4 and VSSC6:
 Dekafix: DEK 5 for the connections WS 10/6 middle as device marker SNAPMARK only for the VSSC6 and DEK5/5 for the terminal points.

Derating curves

VSSC4 GDT MOV TAZ

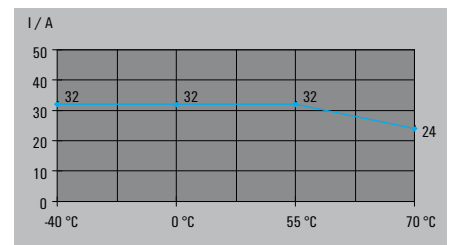

VSSC4 RC

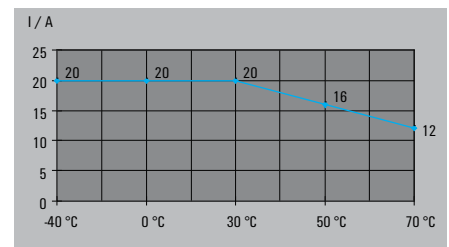

VSSC6 GDT MOV

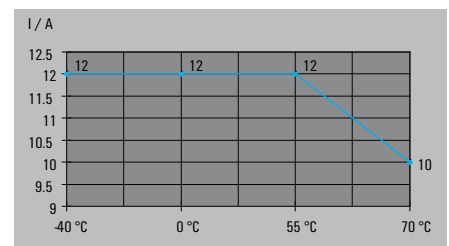

Other VSSC4 und VSS

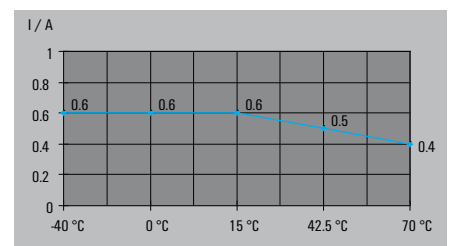

Quick product selection for the VARITECTOR SSC

Technical Data

Interface	Product designation	Part No.
0(4) ... 20 mA / 0 ... 10 V	VSSC4 CL 24 V UC 0.5 A	1063730000
	VSSC6 CL 24 V UC 0.5 A	1064170000
	VSSC6TR CL FG 24 V UC 0.5 A	1064310000
	VSSC4 CL FG 24 V UC 0.5 A	1063770000
	VSSC6 CL FG 24 V UC 0.5 A	1064270000
	VSSC6TR CL FG 24 V UC 0.5 A	1064310000
ARCNET (Plus)	VSSC6 RS485	1064980000
BLN (Building Level Network)	see 0(4) ... 20 mA / 0 ... 10 V	
DeviceNet	VSSC6 RS485	1064980000
DIN measurement bus	see 0(4) ... 20 mA / 0 ... 10 V	
Dupline / Miniplex	VSSC6 CL 12 V DC 0.5 A	1064150000
EIB (European Instalation Bus)	VSSC6 GDT 110 V UC 10 kA	1064690000
EIB (European Instalation Bus)	VSSC6 GDT 110 V UC 20 kA	1064700000
ET200	VSSC6 CL 12 V DC 0.5 A	1064150000
Genius I/O Bus	see 0(4) ... 20 mA / 0 ... 10 V	
Hart	see 0(4) ... 20 mA / 0 ... 10 V	
Cathodic corrosion protection	VSSC6 GDT 230 V UC 20 kA	1064720000
LON™ (Works)	VSSC6 CL 48 V UC 0.5 A	1064190000
M-Bus (Remote meter reading)	see 0(4) ... 20 mA / 0 ... 10 V	
MPI Bus	VSSC6 RS485	1064980000
N2 Bus	VSSC6 SL LD 12 V DC 0.5 A	1064340000
Procontic CS31	VSSC6TR CL FG 12 V DC 0.5 A	1064300000
Profibus DP (FMS)	VSSC6 RS485 DP	
PT100	VSSC6 RTD	1139710000
PSM-EG-RS422...	VSSC6 RS485 DP	1065010000
PSM-EG-RS485...	VSSC6 RS485 DP	1065010000
RS422A, V.11, X.27, RS423A	VSSC6 RS485 DP	1065010000
RS485	VSSC6 RS485 DP	1065010000
RS232-C / V.24	VSSC6 RS232	1064990000
SecurLan-LON™-Bus (Profibus DP)	see 0(4) ... 20 mA / 0 ... 10 V	
TTY, 0(4) - 20 mA	VSSC6 RS485 DP	1065010000
U-BUS	see 0(4) ... 20 mA / 0 ... 10 V	
	VSSC6 GDT 110 V UC 20 kA	1064700000

Note: This tables contains selection recommendations. Our technical consultants will be glad to assist you with your individual application requirements.



VARITECTOR SSC 6AN

Lightning and surge protection in terminal block design

Lightning and surge protection in 6 mm overall width for measurement and control circuits including isolation/measuring function

The VARITECTOR SSC combined surge protection, a direct PE contact function, separation of signal paths and operational status indication in one module. It is suitable for C&I applications.

The disconnect lever in the terminal guarantees that the measurement/control circuit can be quickly and precisely switched off to test the signal path. Using a test plug (PS 2.3 mm), the measuring instrument can be easily inserted into the integrated test socket on Torx®/Slot headed screws. The shield can be attached onto the additional lower level of the VSSC 6AN which then leads directly to the PE potential on the mounting rail. Permanent shielding can be implemented easily using the EMC set. Weidmuller's SNAPMARK device marker can be snapped onto a terminal so that the equipment identification can be easily read regardless of the installation position. The VSSC 6AN features all the advantages found in the VARITECTOR SSC product line: a thin 6.2 mm width, quick PE contact to rail (with up to 20 kA discharge capacity), simple color coding for quick identification, large-surface versatile markers, and the new Torx®/slot headed screw.

All VARITECTOR products comply with the latest IEC 61643-21:2008 requirement for a new overstress mode and with categories D1, C3, C2 and C1 according to IEC 61643-22.

Convenient

Connection convenience is assured by a clamping range of 0.5 mm² to 6 mm² with a Torx®/slot headed screw and a 0.8 Nm tightening torque.



Space-saving

A terminal of just 6.2 mm for two binary signals or one analog signals. Terminals can be fitted side by side.

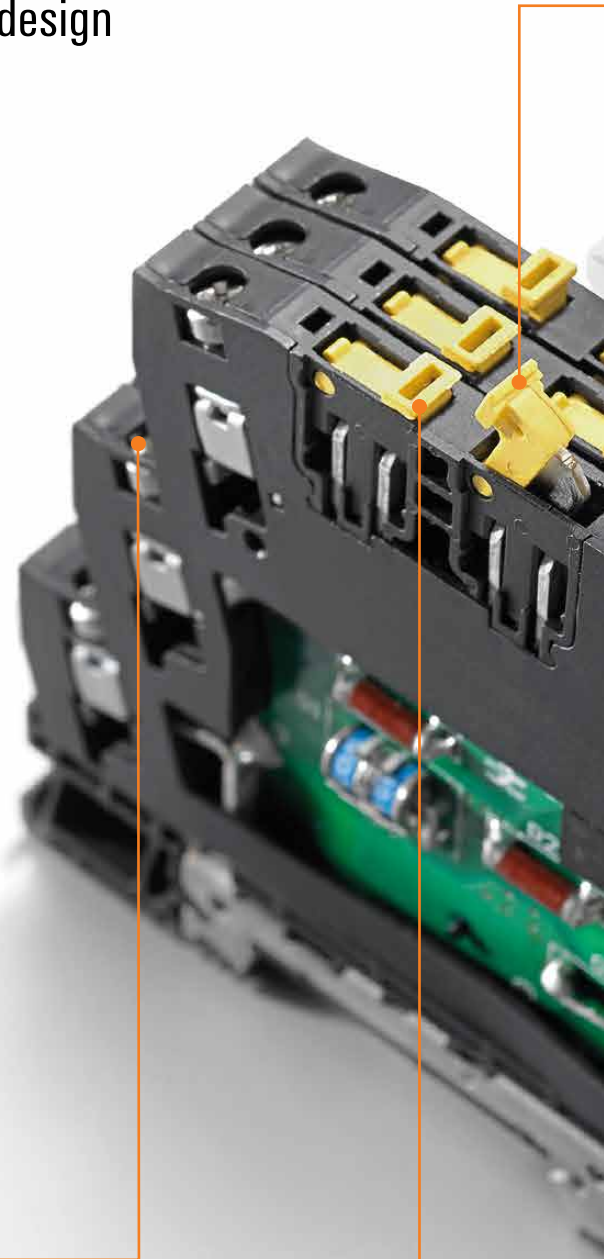

Simple and precise isolation

The disconnect lever guarantees a simple signal path disconnection and a safe disconnect point that is easy to see.

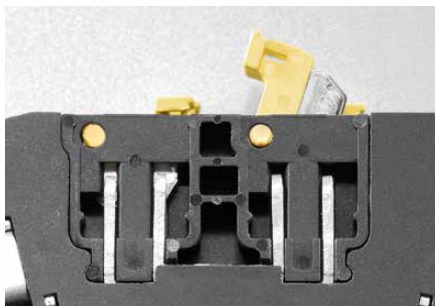

Fast identification

Versatile marking options: markers for equipment and terminals and SNAPMARK markers that are easy to read in any installation position.



Testing and measuring

To enable simple testing it is possible to insert the test plug (PS 2.3 mm) of the measuring instrument into the integrated test socket of the Torx®/slot headed screw.



Easy and safe

A shield can be mounted on both sides of the unit which will provide direct connection to PE. It features a very high discharge current of up to 20 kA for increased plant safety.

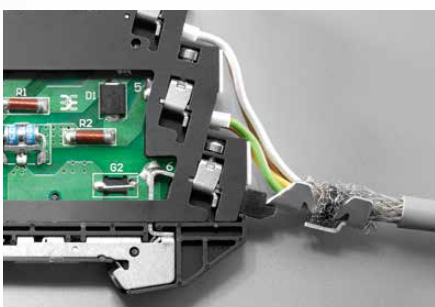

VSSC 6 CL and CL FG - protection for analog signals

- Two-stage surge protection with screw connection for measurement and control signals
- Surge protection in terminal block design
- Modular width of only 6.2 mm
- Space-saving design: 1 analog signal
- Torx® slotted screw connection
- Can be used in compliance with installation standard IEC 62305
- Tested in accordance with IEC 61643-21: D1, C2, C3
- Integrated PE foot, safely discharges up to 20 kA (8/20 μs) and 2.5 kA (10/350 μs) to PE

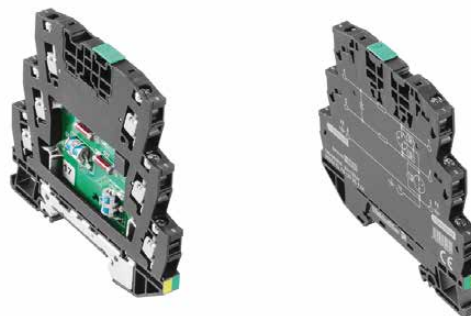

Technical Data

Rated current	500 mA
Dielectric strength at FG against PE	≥ 500 V
Volume resistance	1.8 Ω 10 %
Overload - failure mode	Modus 2
Requirements category acc. to IEC 61643-21	C2, C3, D1
Standards	IEC 61643-21
Surge current-carrying capacity C1	
Surge current-carrying capacity C2	2.5 kA
Surge current-carrying capacity C3	50 A
Surge current-carrying capacity D1	0.5 kA
Discharge current I _a (8/20 μs) wire-wire/wire-PE/GND-PE	2.5 kA / 2.5 kA /
Discharge I _{max} (8/20 μs) wire-wire/wire-PE/GND-PE	5 kA / 5 kA /
Lightning test I _{imp} (10/350 μs) wire-wire/wire-PE/GND-PE	/ 0.5 kA /
Storage temperature	-40 °C...+80 °C
Ambient temperature (operational)	-40 °C...+70 °C
Protection degree	IP 20
UL 94 flammability rating	V-0

Connection data

Type of connection	Screw connection, Torx® T15, Slotted 0.8 x 4
Tightening torque	0.5 Nm
Wire connection cross section, finely stranded, max.	4 mm ²
Wire connection cross-section, finely stranded, min.	0.5 mm ²
Wire cross-section, solid, max.	6 mm ²
Wire cross-section, solid, min.	0.5 mm ²
Wire cross-section, stranded, max.	4 mm ²
Wire cross-section, stranded, min.	0.5 mm ²
Stripping length	10 mm
Mounting rail	TS 35

Failure probability

Ages	19
MTTF	6008
SIL in compliance with IEC 61508	2

Approvals

Approvals	CE; GOSTME25; OEVE; TUEV; UL; ROHS
Standards	IEC 61643-21

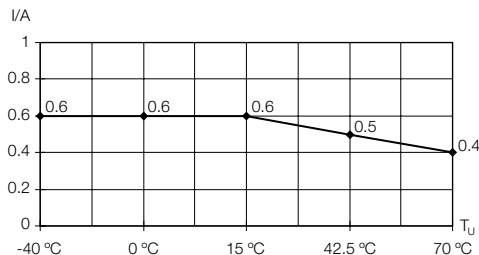
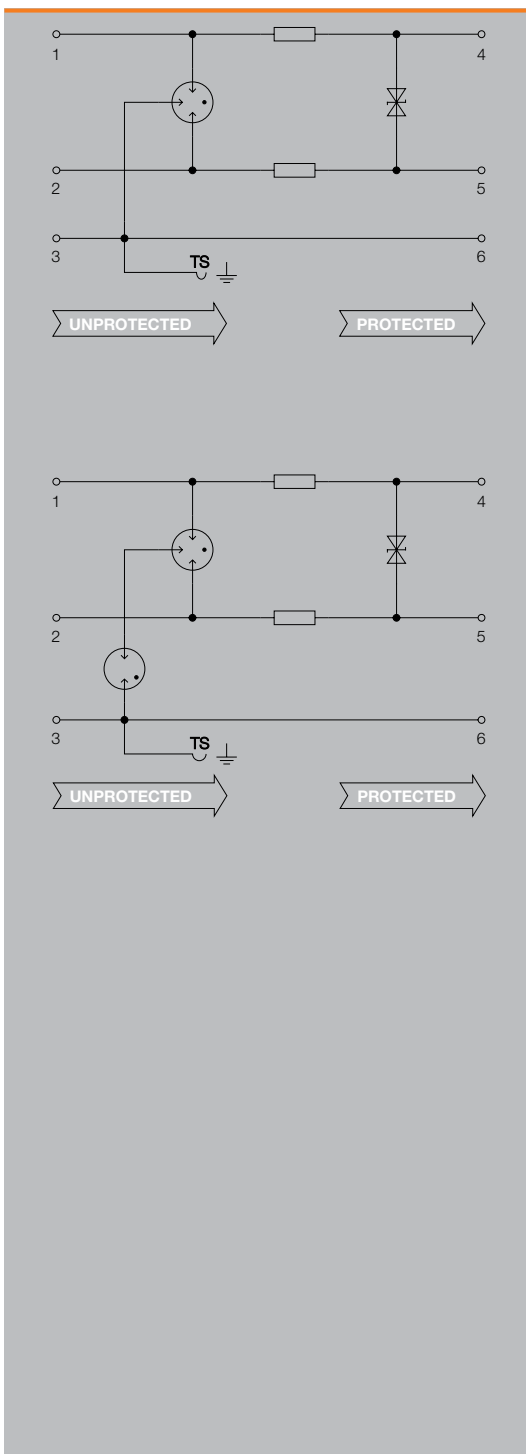

Dimensions

Height x width x depth (mm)	88.5 / 6.1 / 81
-----------------------------	-----------------

Note

VSSC 6 CL and CL FG

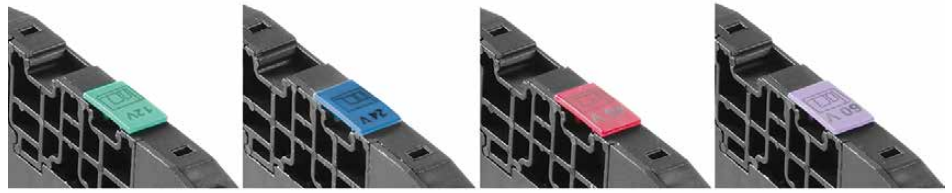

Technical Data

	CL 12 V DC	CL 24 V UC	CL 48 V UC	CL 60 V UC
Rated voltage (AC)		24 V	48 V	60 V
Rated voltage (DC)	12 V	34 V	68 V	85 V
Max. continuous voltage, U _c (AC)		30 V	60 V	75 V
Max. continuous voltage, U _c (DC)	15 V	42 V	85 V	106 V
Rated current	500 mA	500 mA	500 mA	500 mA
Optical function display	No	No	No	No
Isolating function	No	No	No	No
Input attenuation	≤ 700 kHz	3.4 MHz	5 MHz	6.8 MHz
Pulse-reset capacity	≤ 20 ms	≤ 170 ms	≤ 150 ms	≤ 20 ms
Residual voltage, U _r typical	900 V	900 V	764 V	777 V

Ordering Data

Type	VSSC6 CL 12VDC 0.5A	VSSC6 CL 24VAC/DC 0.5A	VSSC6 CL 48VAC/DC 0.5A	VSSC6 CL 60VAC/DC 0.5A
Part No.	1064150000	1064170000	1064190000	1064210000
Qty.	10 ST	10 ST	10 ST	10 ST
Note	End plate AP VSSC6 1063110000	End plate AP VSSC6 1063110000	End plate AP VSSC6 1063110000	End plate AP VSSC6 1063110000

Technical Data

	CLFG 12 V DC	CLFG 24 V UC	CLFG 48 V UC	CLFG 60 V UC
Rated voltage (AC)		24 V	48 V	60 V
Rated voltage (DC)	12 V	34 V	68 V	85 V
Max. continuous voltage, U _c (AC)		30 V	60 V	75 V
Max. continuous voltage, U _c (DC)	15 V	42 V	85 V	106 V
Rated current	500 mA	500 mA	500 mA	500 mA
Optical function display	No	No	No	No
Isolating function	No	No	No	No
Input attenuation	≤ 700 kHz	3.4 MHz	5 MHz	6.8 MHz
Pulse-reset capacity	≤ 20 ms	≤ 20 ms	≤ 20 ms	≤ 20 ms
Residual voltage, U _r typical	1600 V	1632 V	1506 V	1512 V

Ordering Data

Type	VSSC6 CL FG 12VDC 0.5A	VSSC6 CLFG24VAC/DC0.5A	VSSC6 CLFG48VAC/DC0.5A	VSSC6 CLFG60VAC/DC0.5A
Part No.	1064260000	1064270000	1064280000	1064290000
Qty.	10 ST	10 ST	10 ST	10 ST
Note	End plate AP VSSC6 1063110000	End plate AP VSSC6 1063110000	End plate AP VSSC6 1063110000	End plate AP VSSC6 1063110000

VSSC 6 TR CL and TR CL FG - protection for floating current loops

- Two-stage surge protection with screw connection for measurement and control signals
- Surge protection in terminal block design
- Modular width of only 6.2 mm
- Space-saving design: 1 analog signal
- Torx® slotted screw connection
- Can be used in compliance with installation standard IEC 62305
- Tested in accordance with IEC 61643-21: D1, C2, C3
- Integrated PE foot, safely discharges up to 20 kA (8/20 μs) and 2.5 kA (10/350 μs) to PE

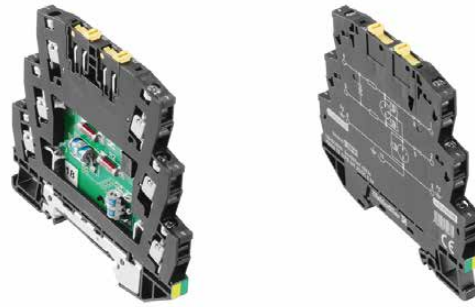

Technical Data

Rated current	500 mA
Dielectric strength at FG against PE	≥ 500 V
Volume resistance	1.8 Ω 10 %
Overload - failure mode	Modus 2
Requirements category acc. to IEC 61643-21	C2, C3, D1
Standards	IEC 61643-21
Surge current-carrying capacity C1	
Surge current-carrying capacity C2	2.5 kA 8/20 μs 5 kV 1.2/50 μs
Surge current-carrying capacity C3	50 A 10/1000 μs
Surge current-carrying capacity D1	0.5 kA 10/350 μs
Discharge current I _d (8/20 μs) wire-wire/wire-PE/GND-PE	2.5 kA / 2.5 kA /
Discharge I _{max} (8/20 μs) wire-wire/wire-PE/GND-PE	5 kA / 5 kA /
Lightning test I _{imp} (10/350 μs) wire-wire/wire-PE/GND-PE	/ 0.5 kA /
Storage temperature	-40 °C...+80 °C
Ambient temperature (operational)	-40 °C...+70 °C
Protection degree	IP 20
UL 94 flammability rating	V-0
Connection data	
Type of connection	Screw connection, Torx® T15, Slotted 0.8 x 4
Tightening torque	0.5 Nm
Wire connection cross section, finely stranded, max.	4 mm ²
Wire connection cross-section, finely stranded, min.	0.5 mm ²
Wire cross-section, solid, max.	6 mm ²
Wire cross-section, solid, min.	0.5 mm ²
Wire cross-section, stranded, max.	4 mm ²
Wire cross-section, stranded, min.	0.5 mm ²
Stripping length	10 mm
Mounting rail	TS 35
Failure probability	
λges	19
MTTF	6008
SIL in compliance with IEC 61508	2
Approvals	
Approvals	CE; GOSTME25; OEVE; TUEV; UL; ROHS
Standards	IEC 61643-21

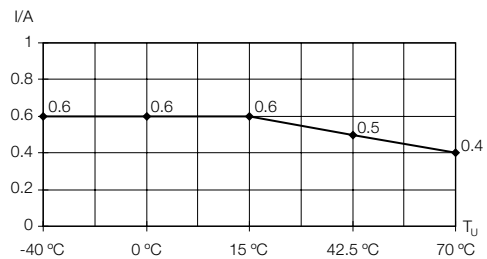
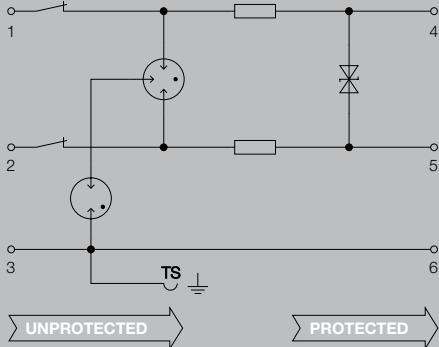
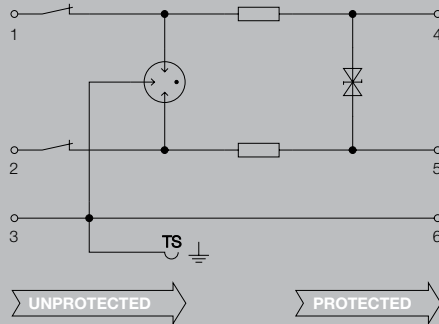

Dimensions

Height x width x depth (mm) 88.5 / 6.1 / 81

Note

VSSC 6TR CL and TR CL FG

Technical Data

	TR CL 12 V DC	TR CL 24 V UC	TR CL 48 V UC	TR CL 60 V UC
Rated voltage (AC)		24 V	48 V	60 V
Rated voltage (DC)	12 V	34 V	68 V	85 V
Max. continuous voltage, U _c (AC)		30 V	60 V	75 V
Max. continuous voltage, U _c (DC)	15 V	42 V	85 V	106 V
Rated current	500 mA	500 mA	500 mA	500 mA
Optical function display	No	No	No	No
Isolating function	Yes	Yes	Yes	Yes
Input attenuation	270 Mhz	270 Mhz	270 Mhz	270 Mhz
Pulse-reset capacity	≤ 20 ms	≤ 170 ms	≤ 150 ms	≤ 20 ms
Residual voltage, U _r typical	900 V	900 V	764 V	777 V

Ordering Data

	TR CL 12 V DC	TR CL 24 V UC	TR CL 48 V UC	TR CL 60 V UC
Type	VSSC6 TR CL 12VDC 0.5A	VSSC6 TRCL24VAC/DC0.5A	VSSC6 TRCL48VAC/DC0.5A	VSSC6 TRCL60VAC/DC0.5A
Part No.	1064220000	1064230000	1064240000	1064250000
Qty.	10 ST	10 ST	10 ST	10 ST
Note	End plate AP VSSC6 1063110000	End plate AP VSSC6 1063110000	End plate AP VSSC6 1063110000	End plate AP VSSC6 1063110000

Technical Data

	TR CLFG 12 V DC	TR CLFG 24 V UC	TR CLFG 48 V UC	TR CLFG 60 V UC
Rated voltage (AC)		24 V	48 V	60 V
Rated voltage (DC)	12 V	34 V	68 V	85 V
Max. continuous voltage, U _c (AC)		30 V	60 V	75 V
Max. continuous voltage, U _c (DC)	15 V	42 V	85 V	106 V
Rated current	500 mA	500 mA	500 mA	500 mA
Optical function display	No	No	No	No
Isolating function	Yes	Yes	Yes	Yes
Input attenuation	270 Mhz	270 Mhz	270 Mhz	270 Mhz
Pulse-reset capacity	≤ 20 ms	≤ 20 ms	≤ 20 ms	≤ 20 ms
Residual voltage, U _r typical	900 V	1632 V	1506 V	1512 V

Ordering Data

	TR CLFG 12 V DC	TR CLFG 24 V UC	TR CLFG 48 V UC	TR CLFG 60 V UC
Type	VSSC6TRCLFG12VDC0.5A	VSSC6TRCLFG24VAC/DC0.5A	VSSC6TRCLFG48VAC/DC0.5A	VSSC6TRCLFG60VAC/DC0.5A
Part No.	1064300000	1064310000	1064320000	1064330000
Qty.	10 ST	10 ST	10 ST	10 ST
Note	End plate AP VSSC6 1063110000	End plate AP VSSC6 1063110000	End plate AP VSSC6 1063110000	End plate AP VSSC6 1063110000



VSSC 6 SL and SL FG - protection for binary signals with signal display

- One-stage surge protection with screw connection for measurement and control signals
- Surge protection in terminal block design
- Modular width of only 6.2 mm
- Space-saving design for two signals
- Torx® slotted screw connection
- Can be used in compliance with installation standard IEC 62305
- Tested in accordance with IEC 61643-21: C1, C2
- Integrated PE foot, safely discharges up to 20 kA (8/20 µs) and 2.5 kA (10/350 µs) to PE

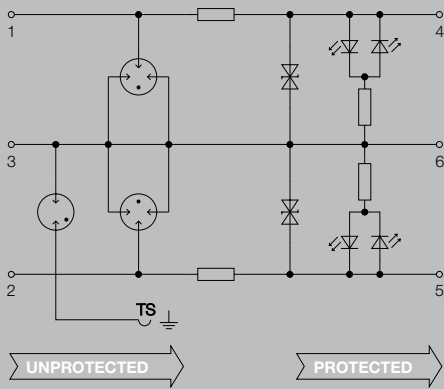
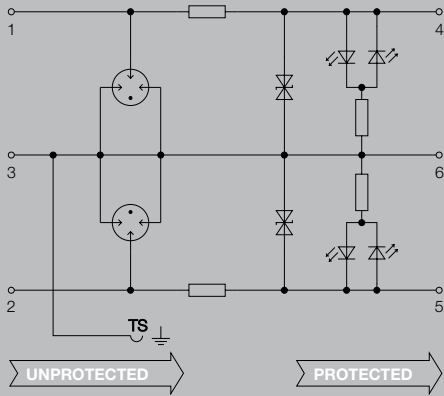
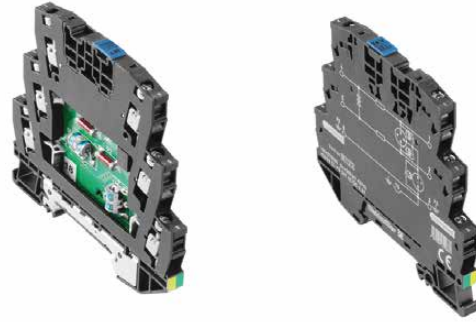

Technical Data

Rated current	500 mA
Dielectric strength at FG against PE	≥ 500 V
Volume resistance	1.8 Ω 10 %
Overload - failure mode	Modus 2
Requirements category acc. to IEC 61643-21	C2, C3, D1
Standards	IEC 61643-21
Surge current-carrying capacity C1	
Surge current-carrying capacity C2	2.5 kA 8/20 µs
Surge current-carrying capacity C3	10 A 10/1000 µs
Surge current-carrying capacity D1	1 kA 10/350 µs
Discharge current I _d (8/20 µs) wire-wire/wire-PE/GND-PE	/ 2.5 kA /
Discharge I _{max} (8/20 µs) wire-wire/wire-PE/GND-PE	/ 10 kA /
Lightning test I _{imp} (10/350 µs) wire-wire/wire-PE/GND-PE	/ 1 kA /
Storage temperature	-40 °C...+80 °C
Ambient temperature (operational)	-40 °C...+70 °C
Protection degree	IP 20
UL 94 flammability rating	V-0

Connection data

Type of connection	Screw connection, Torx® T15, Slotted 0.8 x 4
Tightening torque	0.5 Nm
Wire connection cross section, finely stranded, max.	4 mm ²
Wire connection cross-section, finely stranded, min.	0.5 mm ²
Wire cross-section, solid, max.	6 mm ²
Wire cross-section, solid, min.	0.5 mm ²
Wire cross-section, stranded, max.	4 mm ²
Wire cross-section, stranded, min.	0.5 mm ²
Stripping length	10 mm
Mounting rail	TS 35

Failure probability

Ages	54
MTTF	2114
SIL in compliance with IEC 61508	3

Approvals

Approvals	CE; GOSTME25; OEVE; TUEV; UL; ROHS
Standards	IEC 61643-21

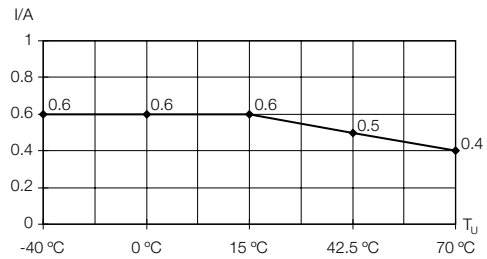

Dimensions

Height x width x depth (mm)	88.5 / 6.1 / 81
-----------------------------	-----------------

Note

VSSC 6 SL and SL FG

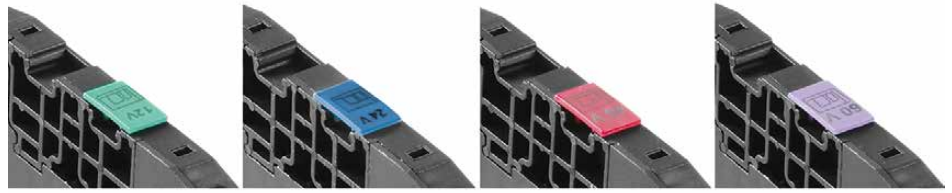

Technical Data

	SL LD 12 V DC	SL LD 24 V UC	SL LD 48 V UC	SL LD 60 V UC
Rated voltage (AC)		24 V	48 V	60 V
Rated voltage (DC)	12 V	34 V	68 V	85 V
Max. continuous voltage, U _c (AC)		30 V	60 V	75 V
Max. continuous voltage, U _c (DC)	15 V	42 V	85 V	106 V
Rated current	500 mA	500 mA	500 mA	500 mA
Optical function display	Yes	Yes	Yes	Yes
Isolating function	No	No	No	No
Input attenuation	750 KHz	3.2 MHz	4.6 MHz	5.5 MHz
Pulse-reset capacity	≤ 20 ms	≤ 20 ms	≤ 20 ms	≤ 20 ms
Residual voltage, U _r typical	74 V	110 V	174 V	222 V

Ordering Data

	SL LD 12 V DC	SL LD 24 V UC	SL LD 48 V UC	SL LD 60 V UC
Type	VSSC6SL LD 12VDC 0.5A	VSSC6SL LD24VAC/DC0.5A	VSSC6SL LD48VAC/DC0.5A	VSSC6SL LD60VAC/DC0.5A
Part No.	1064340000	1064350000	1064360000	1064370000
Qty.	10 ST	10 ST	10 ST	10 ST
Note	End plate AP VSSC6 1063110000	End plate AP VSSC6 1063110000	End plate AP VSSC6 1063110000	End plate AP VSSC6 1063110000

Technical Data

	SLFG LD 12 V DC	SLFG LD 24 V UC	SLFG LD 48 V UC	SLFG LD 60 V UC
Rated voltage (AC)		24 V	48 V	60 V
Rated voltage (DC)	12 V	34 V	68 V	85 V
Max. continuous voltage, U _c (AC)		30 V	60 V	75 V
Max. continuous voltage, U _c (DC)	15 V	42 V	85 V	106 V
Rated current	500 mA	200 mA	10 mA	1.5 mA
Optical function display	Yes	Yes	Yes	Yes
Isolating function	No	No	No	No
Input attenuation	750 KHz	3.2 MHz	4.6 MHz	5.5 MHz
Pulse-reset capacity	≤ 20 ms	≤ 20 ms	≤ 20 ms	≤ 20 ms
Residual voltage, U _r typical	74 V	110 V	174 V	222 V

Ordering Data

	SLFG LD 12 V DC	SLFG LD 24 V UC	SLFG LD 48 V UC	SLFG LD 60 V UC
Type	VSSC6SL FG LD12VDC0.5A	VSSC6SLFGLD24VAC/DC0.5A	VSSC6SLFGLD48VAC/DC0.5A	VSSC6SLFGLD60VAC/DC0.5A
Part No.	1064420000	1064430000	1064440000	1064470000
Qty.	10 ST	10 ST	10 ST	10 ST
Note	End plate AP VSSC6 1063110000	End plate AP VSSC6 1063110000	End plate AP VSSC6 1063110000	End plate AP VSSC6 1063110000

VSSC 6 TR SL and TR SL FG - protection for floating signals with signal display

- Two-stage surge protection with screw connection for measurement and control signals with signal display
- Surge protection in terminal block design
- Modular width of only 6.2 mm
- Space-saving design for two signals
- Torx® slotted screw connection
- Can be used in compliance with installation standard IEC 62305
- Tested in accordance with IEC 61643-21: D1, C2, C3
- Integrated PE foot, safely discharges up to 20 kA (8/20 µs) and 2.5 kA (10/350 µs) to PE

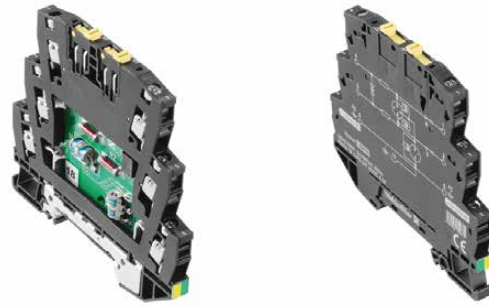

Technical Data

Rated current	500 mA
Dielectric strength at FG against PE	≥ 500 V
Volume resistance	1.8 Ω 10 %
Overload - failure mode	Modus 2
Requirements category acc. to IEC 61643-21	C2, C3, D1
Standards	IEC 61643-21
Surge current-carrying capacity C1	
Surge current-carrying capacity C2	2.5 kA 8/20 µs 5 kV 1.2/50 µs
Surge current-carrying capacity C3	10 A 10/1000 µs
Surge current-carrying capacity D1	1 kA 10/350 µs
Discharge current I_t (8/20 µs) wire-wire/wire-PE/GND-PE	/ 2.5 kA /
Discharge I_{max} (8/20 µs) wire-wire/wire-PE/GND-PE	/ 10 kA /
Lightning test I_{imp} (10/350 µs) wire-wire/wire-PE/GND-PE	/ 1 kA /
Storage temperature	-40 °C...+80 °C
Ambient temperature (operational)	-40 °C...+70 °C
Protection degree	IP 20
UL 94 flammability rating	V-0

Connection data

Type of connection	Screw connection, Torx® T15, Slotted 0.8 x 4
Tightening torque	0.5 Nm
Wire connection cross section, finely stranded, max.	4 mm ²
Wire connection cross-section, finely stranded, min.	0.5 mm ²
Wire cross-section, solid, max.	6 mm ²
Wire cross-section, solid, min.	0.5 mm ²
Wire cross-section, stranded, max.	4 mm ²
Wire cross-section, stranded, min.	0.5 mm ²
Stripping length	10 mm
Mounting rail	TS 35

Failure probability

Ages	54
MTTF	2114
SIL in compliance with IEC 61508	3

Approvals

Approvals	CE; OEVE; TUEV; UL; ROHS
Standards	IEC 61643-21

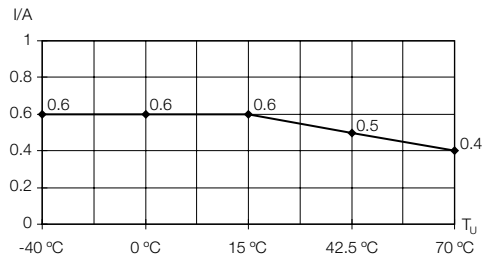
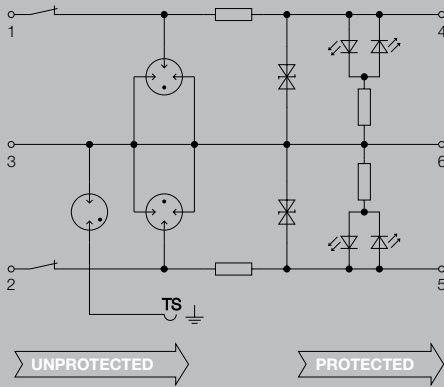
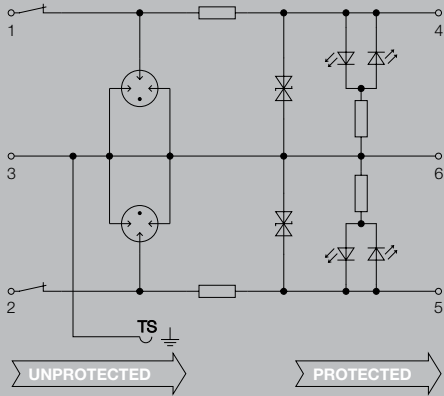

Dimensions

Height x width x depth (mm)	88.5 / 6.1 / 81
-----------------------------	-----------------

Note

VSSC 6 TR SL and TR CL FG

Technical Data

	TR SL LD 12 V DC	TR SL LD 24 V UC	TR SL LD 48 V UC	TR SL LD 60 V UC
Rated voltage (AC)		24 V	48 V	60 V
Rated voltage (DC)	12 V	34 V	68 V	85 V
Max. continuous voltage, U _c (AC)		30 V	60 V	75 V
Max. continuous voltage, U _c (DC)	15 V	42 V	85 V	106 V
Rated current	500 mA	500 mA	500 mA	500 mA
Optical function display	Yes	Yes	Yes	Yes
Isolating function	Yes	Yes	Yes	Yes
Input attenuation	750 KHz	3.2 MHz	4.6 MHz	5.5 MHz
Pulse-reset capacity	≤ 20 ms	≤ 20 ms	≤ 20 ms	≤ 20 ms
Residual voltage, U _r typical	74 V	110 V	174 V	222 V

Ordering Data

	TR SL LD 12 V DC	TR SL LD 24 V UC	TR SL LD 48 V UC	TR SL LD 60 V UC
Type	VSSC6TRSLLD12VDC0.5A	VSSC6TRSLLD24VAC/DC0.5A	VSSC6TRSLLD48VAC/DC0.5A	VSSC6TRSLLD60VAC/DC0.5A
Part No.	1064380000	1064390000	1064400000	1064410000
Qty.	10 ST	10 ST	10 ST	10 ST
Note	End plate AP VSSC6 1063110000	End plate AP VSSC6 1063110000	End plate AP VSSC6 1063110000	End plate AP VSSC6 1063110000

Technical Data

	TR SLFG LD 12 V DC	TR SLFG LD 24 V UC	TR SLFG LD 48 V UC	TR SLFG LD 60 V UC
Rated voltage (AC)		24 V	48 V	60 V
Rated voltage (DC)	12 V	34 V	68 V	85 V
Max. continuous voltage, U _c (AC)		30 V	60 V	75 V
Max. continuous voltage, U _c (DC)	15 V	42 V	85 V	106 V
Rated current	500 mA	200 mA	10 mA	1.5 mA
Optical function display	Yes	Yes	Yes	Yes
Isolating function	Yes	Yes	Yes	Yes
Input attenuation	750 KHz	3.2 MHz	4.6 MHz	5.5 MHz
Pulse-reset capacity	≤ 20 ms	≤ 20 ms	≤ 20 ms	≤ 20 ms
Residual voltage, U _r typical	74 V	110 V	174 V	222 V

Ordering Data

	TR SLFG LD 12 V DC	TR SLFG LD 24 V UC	TR SLFG LD 48 V UC	TR SLFG LD 60 V UC
Type	VSSC6TRSLFGLD12VDC0.5A	VSSC6TRSLFGLD24VUC 0.5A	VSSC6TRSLFGLD48VUC 0.5A	VSSC6TRSLFGLD60VUC 0.5A
Part No.	1064490000	1064500000	1064510000	1064520000
Qty.	10 ST	10 ST	10 ST	10 ST
Note	End plate AP VSSC6 1063110000	End plate AP VSSC6 1063110000	End plate AP VSSC6 1063110000	End plate AP VSSC6 1063110000

VSSC 6 MOV - protection with Varistor (MOV)

- One-stage surge protection with screw connection for measurement and control signals
- Surge protection in terminal block design
- Modular width of only 6.2 mm
- Space-saving design for two signals
- Torx® slotted screw connection
- Can be used in compliance with installation standard IEC 62305
- Tested in accordance with IEC 61643-21: C1, C2
- Integrated PE foot, safely discharges up to 20 kA (8/20 μs) and 2.5 kA (10/350 μs) to PE

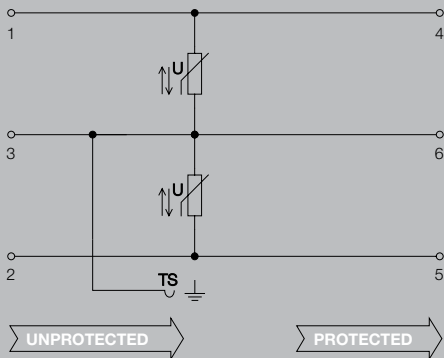
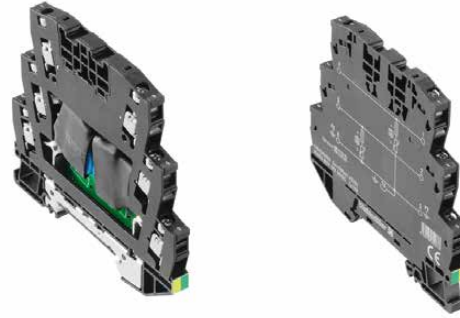

Technical Data

Rated current	12 A
Dielectric strength at FG against PE	
Volume resistance	< 0.1 Ω
Overload - failure mode	Mode 1
Requirements category acc. to IEC 61643-21	C1
Standards	According to IEC61643-21
Surge current-carrying capacity C1	0.25 kA 8/20 μs 0.5 kV 1.2/50 μs
Surge current-carrying capacity C2	
Surge current-carrying capacity C3	
Surge current-carrying capacity D1	
Discharge current I _d (8/20 μs) wire-wire/wire-PE/GND-PE	/ 0.5 kA /
Discharge I _{max} (8/20 μs) wire-wire/wire-PE/GND-PE	/ 1 kA /
Lightning test I _{imp} (10/350 μs) wire-wire/wire-PE/GND-PE	
Storage temperature	-40 °C...+80 °C
Ambient temperature (operational)	-40 °C...+70 °C
Protection degree	IP 20
UL 94 flammability rating	V-0
Connection data	
Type of connection	Screw connection, Torx® T15, Slotted 0.8 x 4
Tightening torque	0.5 Nm
Wire connection cross section, finely stranded, max.	4 mm ²
Wire connection cross-section, finely stranded, min.	0.5 mm ²
Wire cross-section, solid, max.	6 mm ²
Wire cross-section, solid, min.	0.5 mm ²
Wire cross-section, stranded, max.	4 mm ²
Wire cross-section, stranded, min.	0.5 mm ²
Stripping length	10 mm
Mounting rail	TS 35
Failure probability	
λges	26
MTTF	4391
SIL in compliance with IEC 61508	3
Approvals	
Approvals	CE; GOSTME25; OEVE; TUEV; UL; ROHS
Standards	According to IEC61643-21
Height x depth	

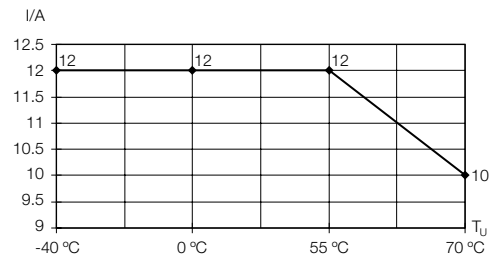

Dimensions

Height x depth (mm) 88.5 / 81

Note

VSSC 6 MOV

Technical Data

	MOV 12 V DC	MOV 24 V UC	MOV 48 V UC	MOV 60 V UC
Rated voltage (AC)		24 V	48 V	60 V
Rated voltage (DC)	12 V	34 V	60 V	85 V
Max. continuous voltage, U _c (AC)		30 V	60 V	75 V
Max. continuous voltage, U _c (DC)	15 V	42 V	85 V	106 V
Rated current	12 A	12 A	12 A	12 A
Optical function display	No	No	No	No
Isolating function	No	No	No	No
Input attenuation				
Pulse-reset capacity				
Residual voltage, U _r typical	57 V	120 V	213 V	269 V
Capacitance	10.8 nF	4.6 nF	2.0 nF	1.78 nF
Width	7.1	7.1	7.1	7.1

Ordering Data

	MOV 12 V DC	MOV 24 V UC	MOV 48 V UC	MOV 60 V UC
Type	VSSC6 MOV 12VDC	VSSC6 MOV 24VAC/DC	VSSC6 MOV 48VAC/DC	VSSC6 MOV 60VAC/DC
Part No.	1064530000	1064540000	1064570000	1064600000
Qty.	8 ST	8 ST	8 ST	8 ST
Note	End plate AP VSSC6 1063110000	End plate AP VSSC6 1063110000	End plate AP VSSC6 1063110000	End plate AP VSSC6 1063110000

Technical Data

	MOV 120 V UC	MOV 150 V UC	MOV 240 V UC
Rated voltage (AC)	120 V	150 V	240 V
Rated voltage (DC)	170 V	212 V	339 V
Max. continuous voltage, U _c (AC)	150 V	188 V	288 V
Max. continuous voltage, U _c (DC)	212 V	266 V	407 V
Rated current	12 A	12 A	12 A
Optical function display	No	No	No
Isolating function	No	No	No
Input attenuation			
Pulse-reset capacity			
Residual voltage, U _r typical	543 V	641 V	1022 V
Capacitance	283 pF	0.8 nF	0.5 nF
Width	12.2	12.2	12.2

Ordering Data

	MOV 120 V UC	MOV 150 V UC	MOV 240 V UC
Type	VSSC6 MOV 120VAC/DC	VSSC6 MOV 150VAC/DC	VSSC6 MOV 240VAC/DC
Part No.	1064610000	1064620000	1064630000
Qty.	5 ST	5 ST	5 ST
Note	End plate AP VSSC6 1063110000	End plate AP VSSC6 1063110000	End plate AP VSSC6 1063110000

VSSC 6 TR LD MOV - protection with varistor (MOV)

- One-stage surge protection with screw connection for measurement and control signals
- Surge protection in terminal block design
- Modular width of only 6.2 mm
- Space-saving design for two signals
- Torx® slotted screw connection
- Can be used in compliance with installation standard IEC 62305
- Tested in accordance with IEC 61643-21: C1, C2
- Integrated PE foot, safely discharges up to 20 kA (8/20 μs) and 2.5 kA (10/350 μs) to PE

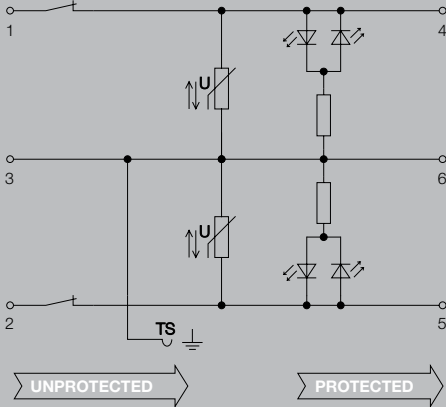
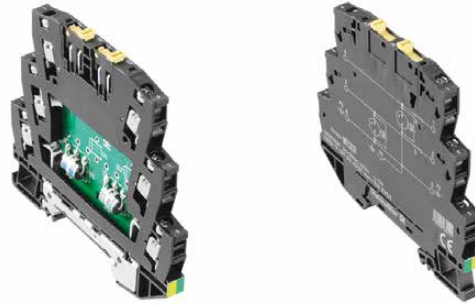

Technical Data

Rated current	12 A
Dielectric strength at FG against PE	
Volume resistance	< 0.1 Ω
Overload - failure mode	Mode 1
Requirements category acc. to IEC 61643-21	C1
Standards	IEC 61643-21
Surge current-carrying capacity C1	0.25 kA 8/20 μs 0.5 kV 1.2/50 μs
Surge current-carrying capacity C2	
Surge current-carrying capacity C3	
Surge current-carrying capacity D1	
Discharge current I _d (8/20 μs) wire-wire/wire-PE/GND-PE	/ 0.5 kA /
Discharge I _{max} (8/20 μs) wire-wire/wire-PE/GND-PE	/ 1 kA /
Lightning test I _{imp} (10/350 μs) wire-wire/wire-PE/GND-PE	
Storage temperature	-40 °C...+80 °C
Ambient temperature (operational)	-40 °C...+70 °C
Protection degree	IP 20
UL 94 flammability rating	V-0
Connection data	
Type of connection	Screw connection, Torx® T15, Slotted 0.8 x 4
Tightening torque	0.5 Nm
Wire connection cross section, finely stranded, max.	4 mm ²
Wire connection cross-section, finely stranded, min.	0.5 mm ²
Wire cross-section, solid, max.	6 mm ²
Wire cross-section, solid, min.	0.5 mm ²
Wire cross-section, stranded, max.	4 mm ²
Wire cross-section, stranded, min.	0.5 mm ²
Stripping length	10 mm
Mounting rail	TS 35
Failure probability	
λges	37
MTTF	3085
SIL in compliance with IEC 61508	3
Approvals	
Approvals	CE; GOSTME25; OEVE; TUEV; UL; ROHS
Standards	IEC 61643-21

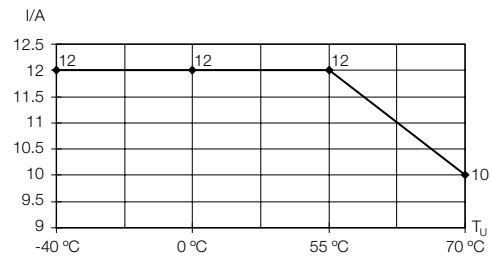

Dimensions	
Height x depth (mm)	88.5 / 81

Note

VSSC 6 TR LD MOV

Technical Data

	TR LD MOV 12 V DC	TR LD MOV 24 V UC	TR LD MOV 48 V UC	TR LD MOV 60 V UC
Rated voltage (AC)		24 V	48 V	60 V
Rated voltage (DC)	12 V	34 V	68 V	85 V
Max. continuous voltage, U _c (AC)		30 V	60 V	75 V
Max. continuous voltage, U _c (DC)	15 V	42 V	85 V	106 V
Rated current	12 A	12 A	12 A	12 A
Optical function display	Yes	Yes	Yes	Yes
Isolating function	Yes	Yes	Yes	Yes
Input attenuation				
Pulse-reset capacity				
Residual voltage, U _r typical	57 V	120 V	213 V	269 V
Capacitance	10.8 nF	4.6 nF	2.0 nF	1.78 nF
Width	7.1	7.1	7.1	7.1

Ordering Data

	VSSC6 TRLDMOV 12VDC	VSSC6 TRLDMOV 24VAC/DC	VSSC6 TRLDMOV 48VAC/DC	VSSC6 TRLDMOV60VAC/DC
Type	VSSC6 TRLDMOV 12VDC	VSSC6 TRLDMOV 24VAC/DC	VSSC6 TRLDMOV 48VAC/DC	VSSC6 TRLDMOV60VAC/DC
Part No.	1064800000	1064810000	1064820000	1064830000
Qty.	8 ST	8 ST	8 ST	8 ST
Note	End plate AP VSSC6 1063110000	End plate AP VSSC6 1063110000	End plate AP VSSC6 1063110000	End plate AP VSSC6 1063110000

Technical Data

	TR LD MOV 120 V UC	TR LD MOV 150 V UC	TR LD MOV 240 V UC
Rated voltage (AC)	120 V	150 V	240 V
Rated voltage (DC)	170 V	212 V	339 V
Max. continuous voltage, U _c (AC)	150 V	188 V	288 V
Max. continuous voltage, U _c (DC)	212 V	266 V	407 V
Rated current	12 A	12 A	12 A
Optical function display	Yes	Yes	Yes
Isolating function	Yes	Yes	Yes
Input attenuation			
Pulse-reset capacity			
Residual voltage, U _r typical	543 V	641 V	1022 V
Capacitance	283 pF	0.8 nF	0.5 nF
Width	12.2	12.2	12.2

Ordering Data

	VSSC6 TRLDMOV120VAC/DC	VSSC6 TRLDMOV150VAC/DC	VSSC6 TRLDMOV240VAC/DC
Type	VSSC6 TRLDMOV120VAC/DC	VSSC6 TRLDMOV150VAC/DC	VSSC6 TRLDMOV240VAC/DC
Part No.	1064840000	1064850000	1064860000
Qty.	5 ST	5 ST	5 ST
Note	End plate AP VSSC6 1063110000	End plate AP VSSC6 1063110000	End plate AP VSSC6 1063110000

VSSC 6 GDT - protection with sparkover gap (GDT)

- One-stage surge protection with screw connection for measurement and control signals
- Surge protection in terminal block design
- Modular width of only 12.4 mm
- Space-saving design for two signals
- Torx® slotted screw connection
- Can be used in compliance with installation standard IEC 62305
- Tested in accordance with IEC 61643-21: D1, C2, C3
- Integrated PE foot, safely discharges up to 20 kA (8/20 μs) and 2.5 kA (10/350 μs) to PE

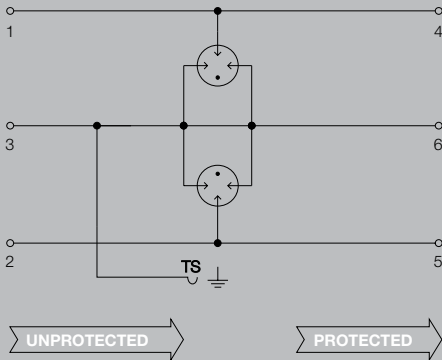
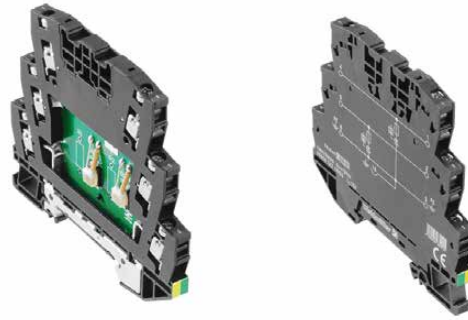

Technical Data

Rated current	12 A
Dielectric strength at FG against PE	
Volume resistance	< 0.1 Ω
Overload - failure mode	Modus 2
Requirements category acc. to IEC 61643-21	C2, C3, D1
Standards	IEC 61643-21
Surge current-carrying capacity C1	
Surge current-carrying capacity C2	2.5 kA 8/20 μs 5 kV 1.2/50 μs
Surge current-carrying capacity C3	50 A 10/1000 μs
Surge current-carrying capacity D1	1 kA 10/350 μs
Discharge current I _d (8/20 μs) wire-wire/wire-PE/GND-PE	/ 2.5 kA /
Discharge I _{max} (8/20 μs) wire-wire/wire-PE/GND-PE	/ 10 kA /
Lightning test I _{imp} (10/350 μs) wire-wire/wire-PE/GND-PE	/ 1 kA /
Storage temperature	-40 °C...+80 °C
Ambient temperature (operational)	-40 °C...+70 °C
Protection degree	IP 20
UL 94 flammability rating	V-0
Connection data	
Type of connection	Screw connection, Torx® T15, Slotted 0.8 x 4
Tightening torque	0.5 Nm
Wire connection cross section, finely stranded, max.	4 mm ²
Wire connection cross-section, finely stranded, min.	0.5 mm ²
Wire cross-section, solid, max.	6 mm ²
Wire cross-section, solid, min.	0.5 mm ²
Wire cross-section, stranded, max.	4 mm ²
Wire cross-section, stranded, min.	0.5 mm ²
Stripping length	10 mm
Mounting rail	TS 35
Failure probability	
λges	10
MTTF	11416
SIL in compliance with IEC 61508	3
Approvals	
Approvals	CE; GOSTME25; TUEV; ROHS
Standards	IEC 61643-21

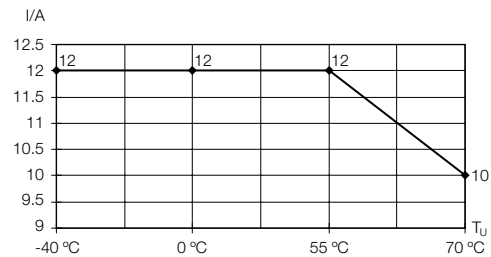

Dimensions

Height x width x depth (mm) 88.5 / 6.1 / 81

Note

VSSC 6 GDT

Technical Data

	GDT 24 V UC 10 kA	GDT 110 V UC 10 kA	GDT 240 V UC 10 kA	GDT 24 V UC 20 kA
Rated voltage (AC)	24 V	110 V	240 V	24 V
Rated voltage (DC)	34 V	156 V	339 V	34 V
Max. continuous voltage, U _c (AC)	30 V	138 V	288 V	30 V
Max. continuous voltage, U _c (DC)	42 V	195 V	407 V	42 V
Rated current	12 A	12 A	12 A	12 A
Optical function display	No	No	No	No
Isolating function	No	No	No	No
Input attenuation				
Pulse-reset capacity				
Residual voltage, U _r typical	976 V	1153 V	1792 V	949 V
Capacitance	1.5 nF	4.2 nF	3.0 nF	5.3 nF

Ordering Data

Type	VSSC6 GDT 24VAC/DC 10kA	VSSC6 GDT 110VAC/DC10kA	VSSC6 GDT 240VAC/DC10kA	VSSC6 GDT 24VAC/DC 20kA
Part No.	1064640000	1064690000	1064710000	1064670000
Qty.	10 ST	10 ST	5 ST	5 ST
Note	End plate AP VSSC6 1063110000	End plate AP VSSC6 1063110000	End plate AP VSSC6 1063110000	End plate AP VSSC6 1063110000

Technical Data

	GDT 110 V UC 20 kA	GDT 240 V UC 20 kA
Rated voltage (AC)	110 V	240 V
Rated voltage (DC)	156 V	339 V
Max. continuous voltage, U _c (AC)	138 V	288 V
Max. continuous voltage, U _c (DC)	195 V	407 V
Rated current	12 A	12 A
Optical function display	No	No
Isolating function	No	No
Input attenuation		
Pulse-reset capacity		
Residual voltage, U _r typical	992 V	1288 V
Capacitance	2.5 nF	2.4 nF

Ordering Data

Type	VSSC6 GDT 110VAC/DC20kA	VSSC6 GDT 240VAC/DC20kA
Part No.	1064700000	1064720000
Qty.	5 ST	5 ST
Note	End plate AP VSSC6 1063110000	End plate AP VSSC6 1063110000



VSSC 6 TR GDT - protection with sparkover gap (GDT)

- One-stage surge protection with screw connection for measurement and control signals
- Surge protection in terminal block design
- Modular width of only 6.2 mm or 12.4 mm
- Space-saving design for two signals
- Torx® slotted screw connection
- Can be used in compliance with installation standard IEC 62305
- Tested in accordance with IEC 61643-21: D1, C2, C3
- Integrated PE foot, safely discharges up to 20 kA (8/20 µs) and 2.5 kA (10/350 µs) to PE

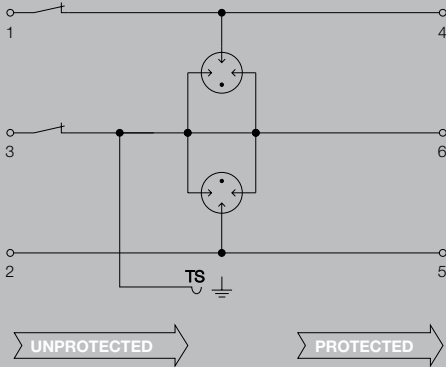

Technical Data

Rated current	12 A
Dielectric strength at FG against PE	
Volume resistance	< 0.1 Ω
Overload - failure mode	Modus 2
Requirements category acc. to IEC 61643-21	C2, C3, D1
Standards	IEC 61643-21
Surge current-carrying capacity C1	
Surge current-carrying capacity C2	2.5 kA 8/20 µs 5 kV 1.2/50 µs
Surge current-carrying capacity C3	50 A 10/1000 µs
Surge current-carrying capacity D1	1 kA 10/350 µs
Discharge current I _d (8/20 µs) wire-wire/wire-PE/GND-PE	/ 2.5 kA /
Discharge I _{max} (8/20 µs) wire-wire/wire-PE/GND-PE	/ 10 kA /
Lightning test I _{imp} (10/350 µs) wire-wire/wire-PE/GND-PE	/ 1 kA /
Storage temperature	-40 °C...+80 °C
Ambient temperature (operational)	-40 °C...+80 °C
Protection degree	IP 20
UL 94 flammability rating	V-0
Connection data	
Type of connection	Screw connection, Torx® T15, Slotted 0.8 x 4
Tightening torque	0.5 Nm
Wire connection cross section, finely stranded, max.	4 mm ²
Wire connection cross-section, finely stranded, min.	0.5 mm ²
Wire cross-section, solid, max.	6 mm ²
Wire cross-section, solid, min.	0.5 mm ²
Wire cross-section, stranded, max.	4 mm ²
Wire cross-section, stranded, min.	0.5 mm ²
Stripping length	10 mm
Mounting rail	TS 35
Failure probability	
Ages	10
MTTF	11416
SIL in compliance with IEC 61508	3
Approvals	
Approvals	CE; GOSTME25; TUEV; ROHS
Standards	IEC 61643-21

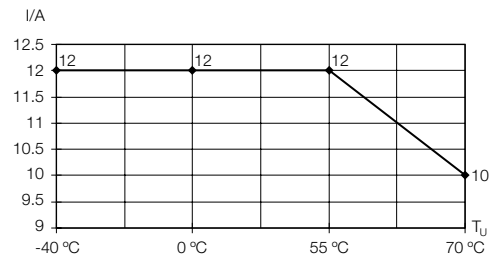

Dimensions

Height x width x depth (mm) 88.5 / 6.1 / 81

Note

VSSC 6 TR GDT

Technical Data

	TR GDT 24 V UC 10 kA	TR GDT 110 V UC 10 kA	TR GDT 240 V UC 10 kA
Rated voltage (AC)	24 V	110 V	240 V
Rated voltage (DC)	34 V	156 V	339 V
Max. continuous voltage, U _c (AC)	30 V	138 V	288 V
Max. continuous voltage, U _c (DC)	42 V	195 V	407 V
Rated current	12 A	12 A	12 A
Optical function display	No	No	No
Isolating function	Yes	Yes	Yes
Input attenuation			
Pulse-reset capacity			
Residual voltage, U _r typical	976 V	1153 V	1792 V
Capacitance	1.5 nF	4.2 nF	3.0 nF

Ordering Data

	TR GDT 24 V UC 10 kA	TR GDT 110 V UC 10 kA	TR GDT 240 V UC 10 kA
Type	VSSC6TRGDT24VAC/DC10kA	VSSC6TRGDT110VAC/DC10kA	VSSC6TRGDT240VAC/DC10kA
Part No.	1064870000	1064890000	1064920000
Qty.	10 ST	10 ST	5 ST
Note	End plate AP VSSC6 1063110000	End plate AP VSSC6 1063110000	End plate AP VSSC6 1063110000



VSSC 6 TAZ and TR TAZ - suppressor diode, with and without isolation option (TR)

- Two-stage surge protection with screw connection for PROFIBUS RS422/485 data interfaces
- Surge protection in terminal block design
- Modular width of only 6.2 mm
- Space-saving design: 1 signal
- Torx® slotted screw connection
- Can be used in compliance with installation standard IEC 62305
- Tested in accordance with IEC 61643-21: D1, C2, C3
- Integrated PE foot, safely discharges up to 20 kA (8/20 μs) and 2.5 kA (10/350 μs) to PE

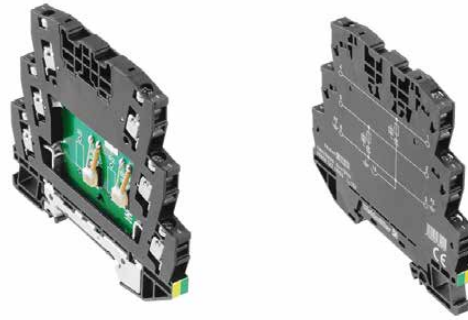

Technical Data

Rated current	12 A
Dielectric strength at FG against PE	
Volume resistance	< 0.1 Ω
Overload - failure mode	Mode 1
Requirements category acc. to IEC 61643-21	C3
Standards	According to IEC61643-21
Surge current-carrying capacity C1	
Surge current-carrying capacity C2	
Surge current-carrying capacity C3	50 A 10/1000 μs
Surge current-carrying capacity D1	
Discharge current I_t (8/20 μs) wire-wire/wire-PE/GND-PE	/ 0.2 kA /
Discharge I_{max} (8/20 μs) wire-wire/wire-PE/GND-PE	/ 0.5 kA /
Lightning test I_{imp} (10/350 μs) wire-wire/wire-PE/GND-PE	
Storage temperature	-40 °C...+80 °C
Ambient temperature (operational)	-40 °C...+70 °C
Protection degree	IP 20
UL 94 flammability rating	V-0
Connection data	
Type of connection	Screw connection, Torx® T15, Slotted 0.8 x 4
Tightening torque	0.5 Nm
Wire connection cross section, finely stranded, max.	4 mm ²
Wire connection cross-section, finely stranded, min.	0.5 mm ²
Wire cross-section, solid, max.	6 mm ²
Wire cross-section, solid, min.	0.5 mm ²
Wire cross-section, stranded, max.	4 mm ²
Wire cross-section, stranded, min.	0.5 mm ²
Stripping length	10 mm
Mounting rail	TS 35
Failure probability	
λges	32
MTTF	3567
SIL in compliance with IEC 61508	3
Approvals	
Approvals	CE; GOSTME25; OEVE; TUEV; UL; ROHS
Standards	According to IEC61643-21

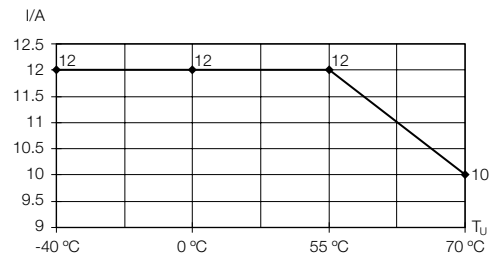
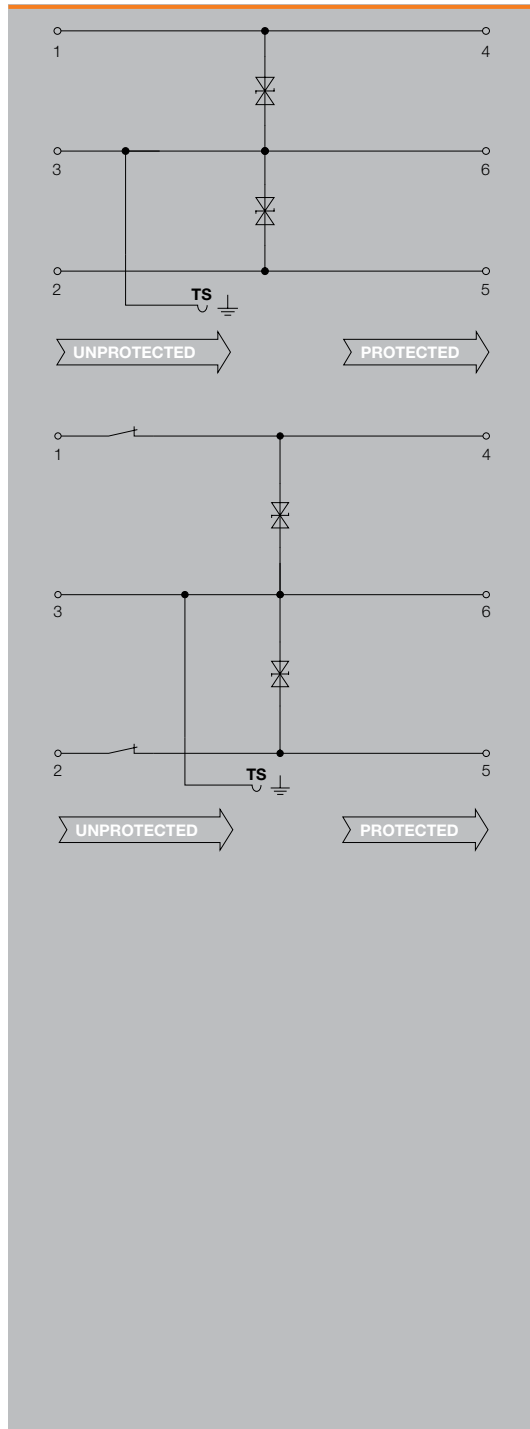

Dimensions

Height x width x depth (mm) 88.5 / 6.1 / 81

Note

VSSC 6 TAZ and TR LD TAZ

Technical Data

	TAZ 12 V DC	TAZ 24 V UC	TAZ 48 V UC	TAZ 60 V UC
Rated voltage (AC)		24 V	48 V	60 V
Rated voltage (DC)	12 V	34 V	68 V	85 V
Max. continuous voltage, U _c (AC)		30 V	60 V	75 V
Max. continuous voltage, U _c (DC)	15 V	42 V	85 V	106 V
Rated current	12 A	12 A	12 A	12 A
Optical function display	No	No	No	No
Isolating function	No	No	No	No
Residual voltage, U _r typical	26 V	62 V	85 V	100 V
Capacitance	4.9 pF	0.8 nF	0.4 nF	0.3 nF

Ordering Data

Type	VSSC6 TAZ 12VDC	VSSC6 TAZ 24VAC/DC	VSSC6 TAZ 48VAC/DC	VSSC6 TAZ 60VAC/DC
Part No.	1064730000	1064740000	1064770000	1064790000
Qty.	10 ST	10 ST	10 ST	10 ST
Note	End plate AP VSSC6 1063110000	End plate AP VSSC6 1063110000	End plate AP VSSC6 1063110000	End plate AP VSSC6 1063110000

Technical Data

	TR LD TAZ 12 V DC	TR LD TAZ 24 V UC	TR LD TAZ 48 V UC	TR LD TAZ 60 V UC
Rated voltage (AC)		24 V	48 V	60 V
Rated voltage (DC)	12 V	34 V	68 V	85 V
Max. continuous voltage, U _c (AC)		30 V	60 V	75 V
Max. continuous voltage, U _c (DC)	15 V	42 V	85 V	106 V
Rated current	12 A	12 A	12 A	12 A
Optical function display	Yes	Yes	Yes	Yes
Isolating function	Yes	Yes	Yes	Yes
Residual voltage, U _r typical	26 V	62 V	85 V	100 V
Capacitance	4.8 nF	0.8 nF	0.4 nF	0.3 nF

Ordering Data

Type	VSSC6 TRLDTAZ 12VDC	VSSC6 TRLDTAZ 24VAC/DC	VSSC6 TRLDTAZ 48VAC/DC	VSSC6 TRLDTAZ 60VAC/DC
Part No.	1064940000	1064950000	1064960000	1064970000
Qty.	10 ST	10 ST	10 ST	10 ST
Note	End plate AP VSSC6 1063110000	End plate AP VSSC6 1063110000	End plate AP VSSC6 1063110000	End plate AP VSSC6 1063110000



VSSC 6 RS485 - protection for RS232/RS485 signal interfaces

- Two-stage surge protection with screw connection for RS422/RS485 data interfaces
- Surge protection in terminal block design
- Modular width of only 6.2 mm
- Space-saving design: 1 signal
- Torx® slotted screw connection
- Can be used in compliance with installation standard IEC 62305
- Tested in accordance with IEC 61643-21: D1, C2, C3
- Integrated PE foot, safely discharges up to 20 kA (8/20 μs) and 2.5 kA (10/350 μs) to PE



Similar to illustration



Similar to illustration

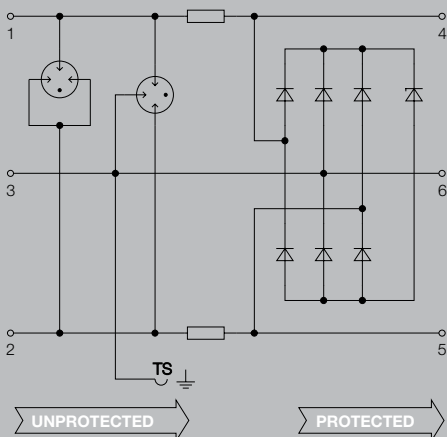
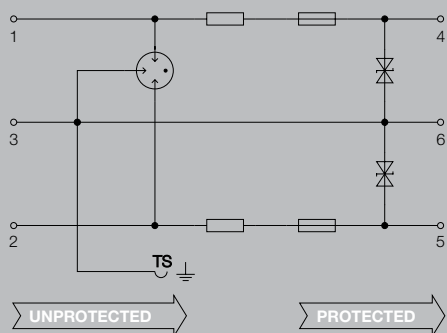

Technical Data

Rated current	500 mA
Dielectric strength at FG against PE	
Volume resistance	1.8 Ω 10 %
Overload - failure mode	Modus 2
Requirements category acc. to IEC 61643-21	C2, C3, D1
Standards	IEC 61643-21
Surge current-carrying capacity C1	
Surge current-carrying capacity C2	2.5 kA 8/20 μs 5 kV 1.2/50 μs
Surge current-carrying capacity C3	10 A 10/1000 μs
Surge current-carrying capacity D1	0.5 kA 10/350 μs
Discharge current I _d (8/20 μs) wire-wire/wire-PE/GND-PE	2.5 kA / 2.5 kA /
Discharge I _{max} (8/20 μs) wire-wire/wire-PE/GND-PE	10 kA / 10 kA /
Lightning test I _{imp} (10/350 μs) wire-wire/wire-PE/GND-PE	/ 0.5 kA /
Storage temperature	-40 °C...+80 °C
Ambient temperature (operational)	-40 °C...+70 °C
Protection degree	IP 20
UL 94 flammability rating	V-0
Connection data	
Type of connection	Screw connection, Torx® T15, Slotted 0.8 x 4
Tightening torque	0.5 Nm
Wire connection cross section, finely stranded, max.	4 mm ²
Wire connection cross-section, finely stranded, min.	0.5 mm ²
Wire cross-section, solid, max.	6 mm ²
Wire cross-section, solid, min.	0.5 mm ²
Wire cross-section, stranded, max.	4 mm ²
Wire cross-section, stranded, min.	0.5 mm ²
Stripping length	10 mm
Mounting rail	TS 35
Failure probability	
Ages	60
MTTF	1903
SIL in compliance with IEC 61508	3
Approvals	
Approvals	CE; GOSTME25; OEVE; TUEV; UL; ROHS
Standards	IEC 61643-21

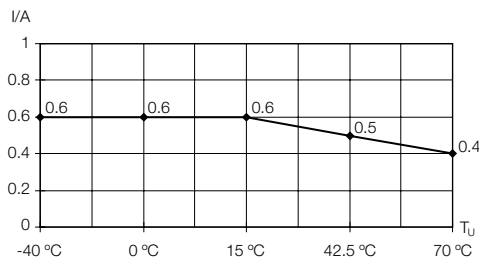

Dimensions

Height x width x depth (mm) 88.5 / 6.1 / 81

Note

VSSC 6 RS485, RS485 DP and RS232

Technical Data	RS485	RS485 DP	RS232
Rated voltage (AC)			
Rated voltage (DC)	12 V	12 V	12 V
Max. continuous voltage, U _c (AC)			
Max. continuous voltage, U _c (DC)	15 V	15 V	15 V
Rated current	500 mA	500 mA	500 mA
Optical function display	No	No	No
Isolating function	No	No	No
Input attenuation	113.6 MHz	113.6 MHz	1.4 MHz
Pulse-reset capacity	≤ 15 ms	≤ 15 ms	≤ 15 ms
Residual voltage, U _r typical	94 V	94 V	80 V

Ordering Data	RS485	RS485 DP	RS232
Type	VSSC6 RS485	VSSC6 RS485 DP	VSSC6 RS232
Part No.	1064980000	1065010000	1064990000
Qty.	10 ST	10 ST	10 ST
Note	End plate AP VSSC6 1063110000	End plate AP VSSC6 1063110000	End plate AP VSSC6 1063110000



VSSC 6 RTD - protection for PT100 signal interfaces

- One-stage surge protection with screw connection for measurement and control signals
- Surge protection in terminal block design
- Modular width of only 6.2 mm
- Space-saving design for two signals
- Torx® slotted screw connection
- Can be used in compliance with installation standard IEC 62305
- Tested in accordance with IEC 61643-21: C1, C2
- Integrated PE foot, safely discharges up to 20 kA (8/20 μs) and 2.5 kA (10/350 μs) to PE



Similar to illustration



Similar to illustration

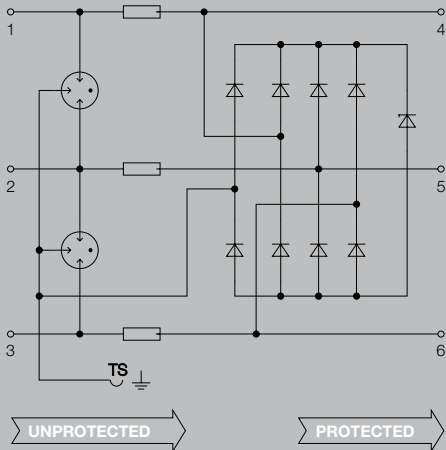

Technical Data

Rated current	300 mA
Dielectric strength at FG against PE	
Volume resistance	1.8 Ω 10 %
Overload - failure mode	Modus 2
Requirements category acc. to IEC 61643-21	C2, C3, D1
Standards	IEC 61643-21
Surge current-carrying capacity C1	
Surge current-carrying capacity C2	2.5 kA 8/20 μs 5 kV 1.2/50 μs
Surge current-carrying capacity C3	10 A 10/1000 μs
Surge current-carrying capacity D1	0.5 kA 10/350 μs
Discharge current I ₁ (8/20 μs) wire-wire/wire-PE/GND-PE	2.5 kA / 2.5 kA /
Discharge I _{max} (8/20 μs) wire-wire/wire-PE/GND-PE	5 kA / 5 kA /
Lightning test I _{imp} (10/350 μs) wire-wire/wire-PE/GND-PE	
Storage temperature	-40 °C...+80 °C
Ambient temperature (operational)	-40 °C...+70 °C
Protection degree	IP 20
UL 94 flammability rating	V-0
Connection data	
Type of connection	Screw connection, Torx® T15, Slotted 0.8 x 4
Tightening torque	Nm
Wire connection cross section, finely stranded, max.	4 mm ²
Wire connection cross-section, finely stranded, min.	0.5 mm ²
Wire cross-section, solid, max.	6 mm ²
Wire cross-section, solid, min.	0.5 mm ²
Wire cross-section, stranded, max.	4 mm ²
Wire cross-section, stranded, min.	0.5 mm ²
Stripping length	10 mm
Mounting rail	TS 35
Failure probability	
λges	63
MTTF	1812
SIL in compliance with IEC 61508	3
Approvals	
Approvals	CE; GOSTME25; OEVE; TUEV; UL; ROHS
Standards	IEC 61643-21

Dimensions

Height x width x depth (mm)	88.5 / 6.1 / 81
-----------------------------	-----------------

Note

VSSC 6 RTD

Technical Data

Rated voltage (AC)
 Rated voltage (DC)
 Max. continuous voltage, U_c (AC)
 Max. continuous voltage, U_c (DC)
 Rated current
 Optical function display
 Isolating function
 Input attenuation
 Residual voltage, U_p typical

RTD	
	1 V
	5 V
	300 mA
	No
	113.6 MHz
	126 V

Ordering Data

Type	VSSC6 RTD
Part No.	1139710000
Qty.	10 ST
Note	End plate AP VSSC6 1063110000



VARITECTOR SSC

Lightning and surge protection in terminal block design

The new and comprehensive surge protection family for measurement and control technology in 6 mm overall width

The interfaces in C&I applications must be protected against surges, since coupling of surges on lines can interfere with or destroy signal inputs. It is therefore necessary that C&I devices be protected in their immediate vicinity. For this purpose, VARITECTOR SSC, with its compact terminal-block format, is ideal for this application. The protective circuits are matched to the current loops and to binary signals.

The VARITECTOR SSC products are tested according to the latest standards (IEC61643-21): They satisfy the safe short-circuit mode in the event of overload by AC currents in classes D1, C2 and C1. The products are ATEX-tested for use in intrinsically safe circuits.



Easy to use

The clamping area of 0.5 mm² – 6 mm² is covered with combined Torx®/Slot headed screw and a tightening torque of 0.8 Nm.



Space-saving

Modular width of terminals just 6.2 mm for two binary signals or per analog signal.

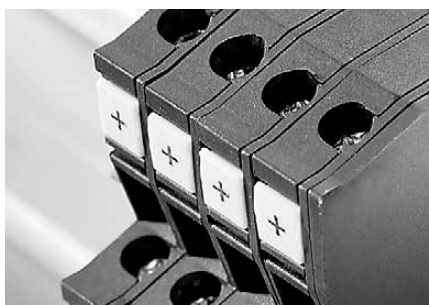

Large variety

A solution for every type of surge protection:
More than 100 variations: current loops and
binary signals for 5 V, 12 V, 24 V, 48 V and
60 V, with integrated components, e.g. varistors.

**Quick identification**

Large-area marking options: marking of devices
and single connections as well as color-
coded marking of the voltage levels for fast
identification in the switching cabinet.

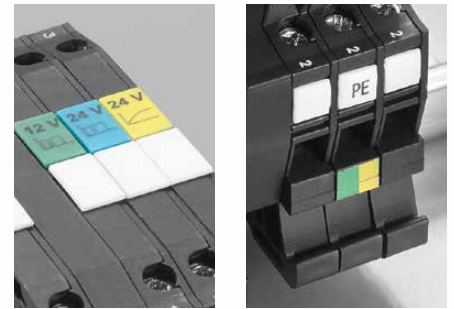
**Simple and safe**

Simple installation and high safety through
direct PE contact when mounting on the
terminal rail, with a very high discharge current
of up to 20 kA.



VSSC 4 CL and CL FG - protection for current loops

- Two-stage surge protection with screw connection for measurement and control signals
- Surge protection in terminal block design
- Modular width of only 6.2 mm
- Space-saving design: 1 analog signal
- Torx® slotted screw connection
- Can be used in compliance with installation standard IEC 62305
- Integrated PE foot, safely discharges up to 20 kA (8/20 µs) and 2.5 kA (10/350 µs) to PE



Technical Data

Rated current	500 mA
Dielectric strength at FG against PE	≥ 500 V
Volume resistance	1.8 Ω 10 %
Overload - failure mode	Modus 2
Requirements category acc. to IEC 61643-21	C2, C3, D1
Standards	IEC 61643-21
Surge current-carrying capacity C1	
Surge current-carrying capacity C2	2.5 kA 8/20 µs 5 kV 1.2/50 µs
Surge current-carrying capacity C3	50 A 10/1000 µs
Surge current-carrying capacity D1	0.5 kA 10/350 µs
Discharge current I _d (8/20 µs) wire-wire/wire-PE/GND-PE	2.5 kA / 2.5 kA /
Discharge I _{max} (8/20 µs) wire-wire/wire-PE/GND-PE	5 kA / 5 kA /
Lightning test I _{imp} (10/350 µs) wire-wire/wire-PE/GND-PE	/ 0.5 kA /
Storage temperature	-40 °C...+80 °C
Ambient temperature (operational)	-40 °C...+70 °C
Protection degree	IP 20
UL 94 flammability rating	V-0
Connection data	
Type of connection	Screw connection, Torx® T15, Slotted 0.8 x 4
Tightening torque	0.5 Nm
Wire connection cross section, finely stranded, max.	4 mm ²
Wire connection cross-section, finely stranded, min.	0.5 mm ²
Wire cross-section, solid, max.	6 mm ²
Wire cross-section, solid, min.	0.5 mm ²
Wire cross-section, stranded, max.	4 mm ²
Wire cross-section, stranded, min.	0.5 mm ²
Stripping length	10 mm
Mounting rail	TS 35
Failure probability	
ages	19
MTTF	6008
SIL in compliance with IEC 61508	2
Approvals	
Approvals	CE; GOSTME25; OEVE; TUEV; UL; ROHS
Standards	IEC 61643-21

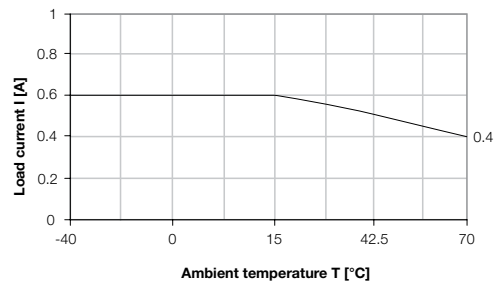
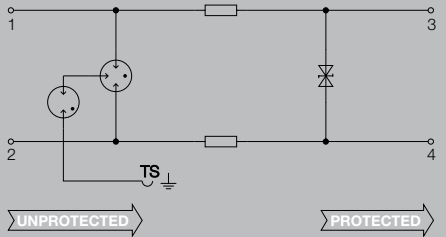
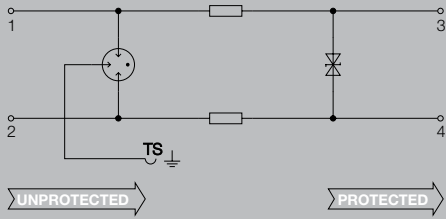

Dimensions	
Height x width x depth (mm)	76 / 6.1 / 58.5

Note

VSSC 4 CL and CL FG

Technical Data

	VSSC4 CL 12 V DC 0.5 A	VSSC4 CL 24 V UC 0.5 A	VSSC4 CL 48 V UC 0.5 A	VSSC4 CL 60 V UC 0.5 A
Rated voltage (AC)		24 V	48 V	60 V
Rated voltage (DC)	12 V	34 V	68 V	85 V
Max. continuous voltage, U _c (AC)		30 V	60 V	75 V
Max. continuous voltage, U _c (DC)	15 V	42 V	85 V	106 V
Rated current	500 mA	500 mA	500 mA	500 mA
Optical function display	No	No	No	No
Isolating function	No	No	No	No
Input attenuation	750 KHz	3.4 MHz	5 Mhz	6.8 MHz
Pulse-reset capacity	≤ 20 ms	≤ 150 ms	≤ 110 ms	≤ 20 ms
Residual voltage, U _r typical	912 V	918 V	773 V	770 V

Ordering Data

Type	VSSC4 CL 12VDC 0.5A	VSSC4 CL 24VAC/DC 0.5A	VSSC4 CL 48VAC/DC 0.5A	VSSC4 CL 60VAC/DC 0.5A
Part No.	1063720000	1063730000	1063740000	1063750000
Qty.	10 ST	10 ST	10 ST	10 ST
Note	End plate AP VSSC4 1063120000	End plate AP VSSC4 1063120000	End plate AP VSSC4 1063120000	End plate AP VSSC4 1063120000

Technical Data

	VSSC4 CL FG 12 V DC 0.5 A	VSSC4 CL FG 24 V UC 0.5 A	VSSC4 CL FG 48 V UC 0.5 A	VSSC4 CL FG 60 V UC 0.5 A
Rated voltage (AC)		24 V	48 V	60 V
Rated voltage (DC)	12 V	34 V	68 V	85 V
Max. continuous voltage, U _c (AC)		30 V	60 V	75 V
Max. continuous voltage, U _c (DC)	15 V	42 V	85 V	106 V
Rated current	500 mA	500 mA	500 mA	500 mA
Optical function display	No	No	No	No
Isolating function	No	No	No	No
Input attenuation	750 KHz	3.4 MHz	5 Mhz	6.8 MHz
Pulse-reset capacity	≤ 20 ms	≤ 20 ms	≤ 20 ms	≤ 20 ms
Residual voltage, U _r typical	1434 V	1407 V	1419 V	1398 V

Ordering Data

Type	VSSC4 CL FG 12VDC 0.5A	VSSC4 CL FG24VAC/DC0.5A	VSSC4 CL FG48VAC/DC0.5A	VSSC4 CL FG60VAC/DC0.5A
Part No.	1063760000	1063770000	1063780000	1063790000
Qty.	10 ST	10 ST	10 ST	10 ST
Note	End plate AP VSSC4 1063120000	End plate AP VSSC4 1063120000	End plate AP VSSC4 1063120000	End plate AP VSSC4 1063120000



VSSC 4 SL and SL FG - protection for binary signal

- Two-stage surge protection with screw connection for measurement and control signals
- Surge protection in terminal block design
- Modular width of only 6.2 mm
- Space-saving design: 1 binary signal
- Torx® slotted screw connection
- Can be used in compliance with installation standard IEC 62305
- Tested in accordance with IEC 61643-21:08 D1, C1, C2, C3
- Integrated PE foot, safely discharges up to 20 kA (8/20 μs) and 2.5 kA (10/350 μs) to PE



Technical Data

Rated current	500 mA
Dielectric strength at FG against PE	≥ 500 V
Volume resistance	1.8 Ω 10 %
Overload - failure mode	Modus 2
Requirements category acc. to IEC 61643-21	C2, C3, D1
Standards	IEC 61643-21
Surge current-carrying capacity C1	
Surge current-carrying capacity C2	2.5 kA 8/20 μs 5 kV 1.2/50 μs
Surge current-carrying capacity C3	10 A 10/1000 μs
Surge current-carrying capacity D1	1 kA 10/350 μs
Discharge current I_t (8/20 μs) wire-wire/wire-PE/GND-PE	/ 2.5 kA /
Discharge I_{max} (8/20 μs) wire-wire/wire-PE/GND-PE	/ 10 kA /
Lightning test I_{imp} (10/350 μs) wire-wire/wire-PE/GND-PE	/ 0.5 kA /
Storage temperature	-40 °C...+80 °C
Ambient temperature (operational)	-40 °C...+70 °C
Protection degree	IP 20
UL 94 flammability rating	V-0
Connection data	
Type of connection	Screw connection, Torx® T15, Slotted 0.8 x 4
Tightening torque	0.5 Nm
Wire connection cross section, finely stranded, max.	4 mm ²
Wire connection cross-section, finely stranded, min.	0.5 mm ²
Wire cross-section, solid, max.	6 mm ²
Wire cross-section, solid, min.	0.5 mm ²
Wire cross-section, stranded, max.	4 mm ²
Wire cross-section, stranded, min.	0.5 mm ²
Stripping length	10 mm
Mounting rail	TS 35
Failure probability	
λges	43
MTTF	2655
SIL in compliance with IEC 61508	3
Approvals	
Approvals	CE; GOSTME25; OEVE; TUEV; UL; ROHS
Standards	IEC 61643-21

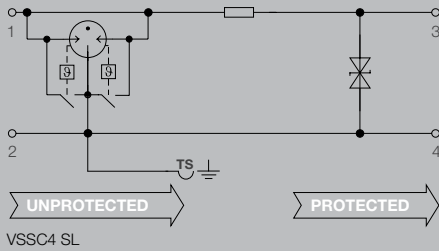

VSSC4 SL

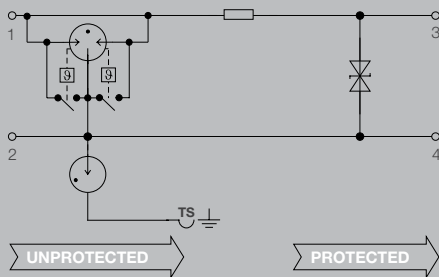

VSSC SL FG

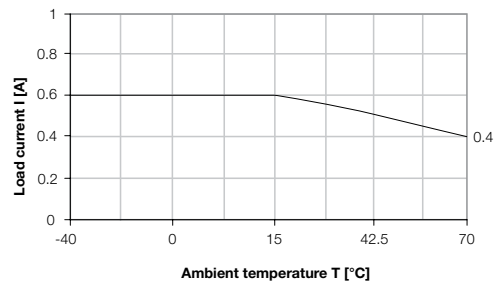

Dimensions

Height x width x depth (mm) 76 / 6.2 / 58.5

Note

VSSC 4 SL and SL FG

Technical Data

	VSSC4 SL 12 V DC 0.5 A	VSSC4 SL 24 V UC 0.5 A	VSSC4 SL 48 V UC 0.5 A	VSSC4 SL 60 V UC 0.5 A
Rated voltage (AC)		24 V	48 V	60 V
Rated voltage (DC)	12 V	34 V	68 V	85 V
Max. continuous voltage, U _c (AC)		30 V	60 V	75 V
Max. continuous voltage, U _c (DC)	15 V	42 V	85 V	106 V
Rated current	500 mA	500 mA	500 mA	500 mA
Optical function display	No	No	No	No
Isolating function	No	No	No	No
Input attenuation	860 KHz	3.4 MHz	5.2 MHz	6.6 MHz
Pulse-reset capacity	≤ 20 ms	≤ 35 ms	≤ 20 ms	≤ 20 ms
Residual voltage, U _r typical	66 V	106 V	160 V	223 V

Ordering Data

	VSSC4 SL 12VDC 0.5A	VSSC4 SL 24VAC/DC 0.5A	VSSC4 SL 48VAC/DC 0.5A	VSSC4 SL 60VAC/DC 0.5A
Type	VSSC4 SL 12VDC 0.5A	VSSC4 SL 24VAC/DC 0.5A	VSSC4 SL 48VAC/DC 0.5A	VSSC4 SL 60VAC/DC 0.5A
Part No.	1063830000	1063840000	1063860000	1063870000
Qty.	10 ST	10 ST	10 ST	10 ST
Note	End plate AP VSSC4 1063120000	End plate AP VSSC4 1063120000	End plate AP VSSC4 1063120000	End plate AP VSSC4 1063120000

Technical Data

	VSSC4 SL FG 12 V DC 0.5 A	VSSC4 SL FG 24 V UC 0.5 A	VSSC4 SL FG 48 V UC 0.5 A	VSSC4 SL FG 60 V UC 0.5 A
Rated voltage (AC)		24 V	48 V	60 V
Rated voltage (DC)	12 V	34 V	68 V	85 V
Max. continuous voltage, U _c (AC)		30 V	60 V	75 V
Max. continuous voltage, U _c (DC)	15 V	42 V	85 V	106 V
Rated current	500 mA	500 mA	500 mA	500 mA
Optical function display	No	No	No	No
Isolating function	No	No	No	No
Input attenuation	860 KHz	3.4 MHz	5.2 MHz	6.6 MHz
Pulse-reset capacity	≤ 20 ms	≤ 20 ms	≤ 35 ms	≤ 20 ms
Residual voltage, U _r typical	66 V	106 V	160 V	223 V

Ordering Data

	VSSC4 SL FG 12VDC 0.5A	VSSC4 SL FG24VAC/DC0.5A	VSSC4 SL FG48VAC/DC0.5A	VSSC4 SL FG60VAC/DC0.5A
Type	VSSC4 SL FG 12VDC 0.5A	VSSC4 SL FG24VAC/DC0.5A	VSSC4 SL FG48VAC/DC0.5A	VSSC4 SL FG60VAC/DC0.5A
Part No.	1063880000	1063890000	1063910000	1063920000
Qty.	10 ST	10 ST	10 ST	10 ST
Note	End plate AP VSSC4 1063120000	End plate AP VSSC4 1063120000	End plate AP VSSC4 1063120000	End plate AP VSSC4 1063120000



VSSC 4 MOV - protection with Varistor (MOV)

- One-stage surge protection with screw connection for measurement and control signals
- Surge protection in terminal block design
- Modular width of only 6.2 mm
- Space-saving design for one signal
- Torx® slotted screw connection
- Can be used in compliance with installation standard IEC 62305
- Tested in accordance with IEC 61643-21:08 : C1, C2, C3
- Integrated PE foot, safely discharges up to 20 kA (8/20 µs) and 2.5 kA (10/350 µs) to PE

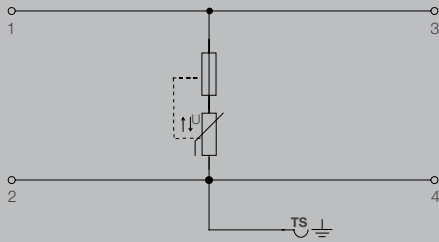

VSSC4 MOV

Technical Data

Rated current	32 A
Dielectric strength at FG against PE	
Volume resistance	< 0.1 Ω
Overload - failure mode	Mode 1
Requirements category acc. to IEC 61643-21	C1
Standards	IEC 61643-21
Surge current-carrying capacity C1	0.25 kA 8/20 µs 0.5 kV 1.2/50 µs
Surge current-carrying capacity C2	1 kA 8/20 µs
Surge current-carrying capacity C3	
Surge current-carrying capacity D1	
Discharge current I_t (8/20 µs) wire-wire/wire-PE/GND-PE	/ 0.5 kA /
Discharge I_{max} (8/20 µs) wire-wire/wire-PE/GND-PE	/ 1 kA /
Lightning test I_{imp} (10/350 µs) wire-wire/wire-PE/GND-PE	
Storage temperature	-40 °C...+80 °C
Ambient temperature (operational)	-40 °C...+70 °C
Protection degree	IP 20
UL 94 flammability rating	V-0
Connection data	
Type of connection	Screw connection, Torx® T15, Slotted 0.8 x 4
Tightening torque	0.5 Nm
Wire connection cross section, finely stranded, max.	4 mm ²
Wire connection cross-section, finely stranded, min.	0.5 mm ²
Wire cross-section, solid, max.	6 mm ²
Wire cross-section, solid, min.	0.5 mm ²
Wire cross-section, stranded, max.	4 mm ²
Wire cross-section, stranded, min.	0.5 mm ²
Stripping length	10 mm
Mounting rail	TS 35
Failure probability	
λges	26
MTTF	4391
SIL in compliance with IEC 61508	3
Approvals	
Approvals	CE; GOSTME25; OEVE; TUEV; UL; ROHS
Standards	IEC 61643-21

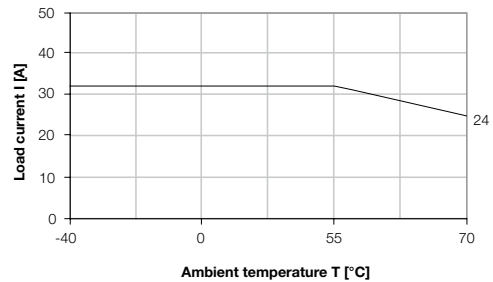

Dimensions

Height x width x depth (mm) 76 / 6.1 / 58.5

Note

VSSC MOV 4 - components

Technical Data

	VSSC4 MOV 12 V DC	VSSC4 MOV 24 V UC	VSSC4 MOV 48 V UC	VSSC4 MOV 60 V UC
Rated voltage (AC)		24 V	48 V	60 V
Rated voltage (DC)	12 V	34 V	68 V	85 V
Max. continuous voltage, U _c (AC)		30 V	60 V	75 V
Max. continuous voltage, U _c (DC)	15 V	42 V	85 V	106 V
Rated current	32 A	32 A	32 A	32 A
Optical function display	No	No	No	No
Isolating function	No	No	No	No
Requirements category acc. to IEC 61643-21	C1	C1	C1, C2	C1, C2
Pulse-reset capacity				
Residual voltage, U _p typical	55 V	116 V	206 V	246 V
Capacitance	11.2 nF	4.8 nF	1.9 nF	1.7 nF

Ordering Data

Type	VSSC4 MOV 12VDC	VSSC4 MOV 24VAC/DC	VSSC4 MOV 48VAC/DC	VSSC4 MOV 60VAC/DC
Part No.	1063950000	1063960000	1063970000	1063980000
Qty.	10 ST	10 ST	10 ST	10 ST
Note	End plate AP VSSC4 1063120000	End plate AP VSSC4 1063120000	End plate AP VSSC4 1063120000	End plate AP VSSC4 1063120000

Technical Data

	VSSC4 MOV 120 V UC	VSSC4 MOV 150 V UC	VSSC4 MOV 240 V UC
Rated voltage (AC)	120 V	150 V	240 V
Rated voltage (DC)	170 V	212 V	339 V
Max. continuous voltage, U _c (AC)	150 V	188 V	288 V
Max. continuous voltage, U _c (DC)	212 V	266 V	407 V
Rated current	32 A	32 A	32 A
Optical function display	No	No	No
Isolating function	No	No	No
Requirements category acc. to IEC 61643-21	C1, C2	C1, C2	C1, C2
Pulse-reset capacity			
Residual voltage, U _p typical	526 V	638 V	1022 V
Capacitance	1.48 nF	0.97 nF	0.7 nF

Ordering Data

Type	VSSC4 MOV 120VAC/DC	VSSC4 MOV 150VAC/DC	VSSC4 MOV 240VAC/DC
Part No.	1063990000	1064010000	1064020000
Qty.	5 ST	5 ST	5 ST
Note	End plate AP VSSC4 1063120000	End plate AP VSSC4 1063120000	End plate AP VSSC4 1063120000



VSSC 4 GDT - protection with sparkover gap (GDT)

- One-stage surge protection with screw connection for measurement and control signals
- Surge protection in terminal block design
- Modular width of only 12.4 mm
- Space-saving design for one signal
- Torx® slotted screw connection
- Can be used in compliance with installation standard IEC 62305
- Tested in accordance with IEC 61643-21:08 : C1, C2, C3
- Integrated PE foot, safely discharges up to 20 kA (8/20 μs) and 2.5 kA (10/350 μs) to PE

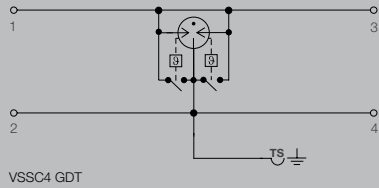
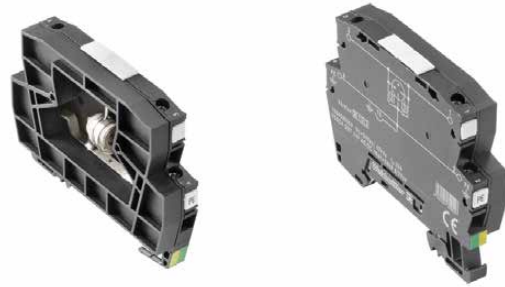

Technical Data

Rated current	32 A
Dielectric strength at FG against PE	
Volume resistance	< 0.1 Ω
Overload - failure mode	Modus 2
Requirements category acc. to IEC 61643-21	C2, C3, D1
Standards	IEC 61643-21
Surge current-carrying capacity C1	
Surge current-carrying capacity C2	5 kA 8/20 μs
Surge current-carrying capacity C3	100 A 10/1000 μs
Surge current-carrying capacity D1	2.5 kA 10/350 μs
Discharge current I _d (8/20 μs) wire-wire/wire-PE/GND-PE	/ 5 kA /
Discharge I _{max} (8/20 μs) wire-wire/wire-PE/GND-PE	/ 20 kA /
Lightning test I _{imp} (10/350 μs) wire-wire/wire-PE/GND-PE	/ 2.5 kA /
Storage temperature	-40 °C...+80 °C
Ambient temperature (operational)	-40 °C...+70 °C
Protection degree	IP 20
UL 94 flammability rating	V-0
Connection data	
Type of connection	Screw connection, Torx® T15, Slotted 0.8 x 4
Tightening torque	0.5 Nm
Wire connection cross section, finely stranded, max.	4 mm ²
Wire connection cross-section, finely stranded, min.	0.5 mm ²
Wire cross-section, solid, max.	6 mm ²
Wire cross-section, solid, min.	0.5 mm ²
Wire cross-section, stranded, max.	4 mm ²
Wire cross-section, stranded, min.	0.5 mm ²
Stripping length	10 mm
Mounting rail	TS 35
Failure probability	
λges	10
MTTF	11416
SIL in compliance with IEC 61508	3
Approvals	
Approvals	CE; GOSTME25; TUEV; ROHS
Standards	IEC 61643-21

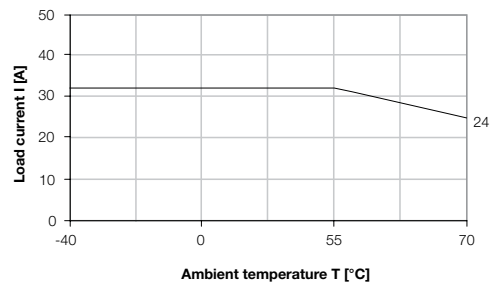

Dimensions

Height x width x depth (mm) 76 / 12.2 / 58.5

Note

VSSC 4 GDT - components

Technical Data

	VSSC4 GDT 110 V UC 20 kA	VSSC4 GDT 240 V UC 20 kA
Rated voltage (AC)	110 V	240 V
Rated voltage (DC)	156 V	339 V
Max. continuous voltage, U _c (AC)	138 V	288 V
Max. continuous voltage, U _c (DC)	195 V	407 V
Rated current	32 A	32 A
Optical function display	No	No
Isolating function	No	No
Residual voltage, U _r typical	845 V	1144 V
Capacitance	4.65 pF	4.65 pF

Ordering Data

	VSSC4 GDT 110VAC/DC20kA	VSSC4 GDT 240VAC/DC20kA
Type	VSSC4 GDT 110VAC/DC20kA	VSSC4 GDT 240VAC/DC20kA
Part No.	1064050000	1064060000
Qty.	5 ST	5 ST
Note	End plate AP VSSC4 1063120000	End plate AP VSSC4 1063120000



VSSC 4 TAZ - protection with suppressor diode (TAZ)

- One-stage surge protection with screw connection for measurement and control signals
- Surge protection in terminal block design
- Modular width of only 6.2 mm
- Space-saving design for one signal
- Torx® slotted screw connection
- Can be used in compliance with installation standard IEC 62305
- Tested in accordance with IEC 61643-21:08 : C1, C2, C3
- Integrated PE foot, safely discharges up to 20 kA (8/20 µs) and 2.5 kA (10/350 µs) to PE

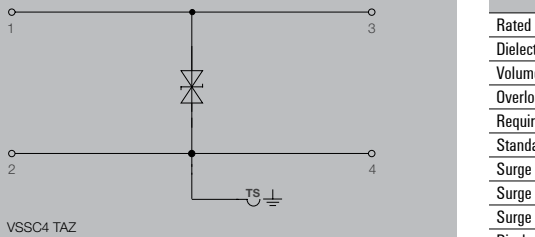

Technical Data

Rated current	32 A
Dielectric strength at FG against PE	
Volume resistance	< 0.1 Ω
Overload - failure mode	Mode 1
Requirements category acc. to IEC 61643-21	C3
Standards	IEC 61643-21
Surge current-carrying capacity C1	
Surge current-carrying capacity C2	
Surge current-carrying capacity D1	
Discharge current I_L (8/20 µs) wire-wire/wire-PE/GND-PE	/ 0.2 kA /
Discharge I_{max} (8/20 µs) wire-wire/wire-PE/GND-PE	/ 0.5 kA /
Lightning test I_{imp} (10/350 µs) wire-wire/wire-PE/GND-PE	
Storage temperature	-40 °C...+80 °C
Ambient temperature (operational)	-40 °C...+70 °C
Protection degree	IP 20
UL 94 flammability rating	V-0
Connection data	
Type of connection	Screw connection, Torx® T15, Slotted 0.8 x 4
Tightening torque	0.5 Nm
Wire connection cross section, finely stranded, max.	4 mm ²
Wire connection cross-section, finely stranded, min.	0.5 mm ²
Wire cross-section, solid, max.	6 mm ²
Wire cross-section, solid, min.	0.5 mm ²
Wire cross-section, stranded, max.	4 mm ²
Wire cross-section, stranded, min.	0.5 mm ²
Stripping length	10 mm
Mounting rail	TS 35
Failure probability	
λges	32
MTTF	3567
SIL in compliance with IEC 61508	3
Approvals	
Approvals	CE; GOSTME25; OEVE; TUEV; UL; ROHS
Standards	IEC 61643-21

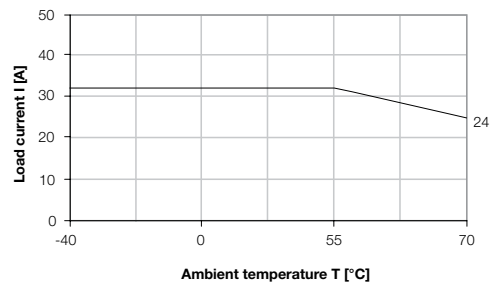

Dimensions	
Height x width x depth (mm)	76 / 6.1 / 58.5

Note

VSSC 4 TAZ - components

Technical Data

	VSSC4 TAZ 12 V DC	VSSC4 TAZ 24 V UC	VSSC4 TAZ 48 V UC	VSSC4 TAZ 60 V UC
Rated voltage (AC)		24 V	48 V	60 V
Rated voltage (DC)	12 V	34 V	75 V	85 V
Max. continuous voltage, U _c (AC)		30 V	60 V	75 V
Max. continuous voltage, U _c (DC)	15 V	42 V	85 V	106 V
Rated current	32 A	32 A	32 A	32 A
Optical function display	No	No	No	No
Isolating function	No	No	No	No
Residual voltage, U _r typical	22 V	61 V	80 V	100 V
Capacitance	5.06 nF	0.82 nF	0.45 nF	0.36 nF
Surge current-carrying capacity C3	50 A	15 A	15 A	15 A

Ordering Data

	VSSC4 TAZ 12VDC	VSSC4 TAZ 24VAC/DC	VSSC4 TAZ 48VAC/DC	VSSC4 TAZ 60VAC/DC
Type	VSSC4 TAZ 12VDC	VSSC4 TAZ 24VAC/DC	VSSC4 TAZ 48VAC/DC	VSSC4 TAZ 60VAC/DC
Part No.	1064070000	1064080000	1064090000	1064110000
Qty.	10 ST	10 ST	10 ST	10 ST
Note	End plate AP VSSC4 1063120000	End plate AP VSSC4 1063120000	End plate AP VSSC4 1063120000	End plate AP VSSC4 1063120000



VSSC 4 RC - protection with a combination of resistors and capacitors

- Two-stage surge protection with screw connection for measurement and control signals
- Surge protection in terminal block design
- Modular width of only 12.4 mm
- Space-saving design for one signal
- Torx® slotted screw connection
- Can be used in compliance with installation standard IEC 62305
- Tested in accordance with IEC 61643-21:08
- Integrated PE foot, safely discharges up to 20 kA (8/20 μs) and 2.5 kA (10/350 μs) to PE

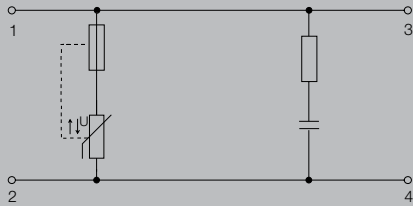

VSSC4 RC

Technical Data

Rated current	20 A
Dielectric strength at FG against PE	
Volume resistance	< 0.1 Ω
Overload - failure mode	Mode 1
Requirements category acc. to IEC 61643-21	C1
Standards	IEC 61643-21
Surge current-carrying capacity C1	0.25 kA 8/20 μs 0.5 kV 1.2/50 μs
Surge current-carrying capacity C2	
Surge current-carrying capacity C3	
Surge current-carrying capacity D1	
Discharge current I _s (8/20 μs) wire-wire/wire-PE/GND-PE	/ 0.5 kA /
Discharge I _{max} (8/20 μs) wire-wire/wire-PE/GND-PE	
Lightning test I _{imp} (10/350 μs) wire-wire/wire-PE/GND-PE	
Storage temperature	-40 °C...+80 °C
Ambient temperature (operational)	-40 °C...+70 °C
Protection degree	IP 20
UL 94 flammability rating	V-0
Connection data	
Type of connection	Screw connection, Torx® T15, Slotted 0.8 x 4
Tightening torque	0.5 Nm
Wire connection cross section, finely stranded, max.	4 mm ²
Wire connection cross-section, finely stranded, min.	0.5 mm ²
Wire cross-section, solid, max.	6 mm ²
Wire cross-section, solid, min.	0.5 mm ²
Wire cross-section, stranded, max.	4 mm ²
Wire cross-section, stranded, min.	0.5 mm ²
Stripping length	10 mm
Mounting rail	TS 35
Failure probability	
Ages	28
MTTF	4048
SIL in compliance with IEC 61508	3
Approvals	
Approvals	CE; GOSTME25; OEVE; TUEV; UL; ROHS
Standards	IEC 61643-21

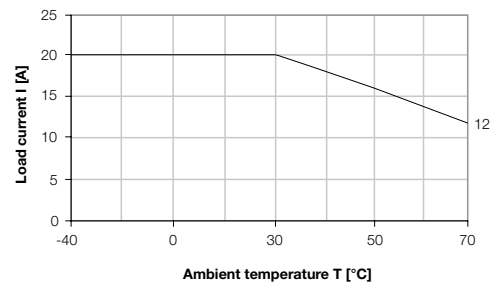

Dimensions

Height x width x depth (mm) 76 / 12.2 / 58.5

Note

VSSC 4 RC - components

Technical Data

	VSSC4 RC 24 V UC	VSSC4 RC 240 V UC
Rated voltage (AC)	24 V	240 V
Rated voltage (DC)	34 V	339 V
Max. continuous voltage, U _c (AC)	30 V	275 V
Max. continuous voltage, U _c (DC)	42 V	388 V
Rated current	20 A	20 A
Optical function display	No	No
Isolating function	No	No
Input attenuation		
Pulse-reset capacity		
Residual voltage, U _r typical	119 V	500 V
Capacitance	8.5 nF	15.9 nF

Ordering Data

	VSSC4 RC 24VAC/DC	VSSC4 RC 240VAC/DC
Type	VSSC4 RC 24VAC/DC	VSSC4 RC 240VAC/DC
Part No.	1064120000	1064130000
Qty.	5 ST	5 ST
Note	End plate AP VSSC4 1063120000	End plate AP VSSC4 1063120000



Surge Protection for Data Signals

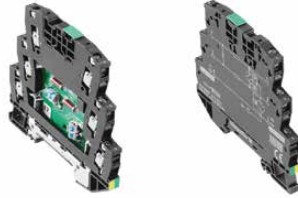

RS 232

Serial interface for point-to-point connections up to 20 kbit/s
 Voltage signal to earth:
 logic 1 (mark) -15 V to -3 V
 logic 0 (space) +3 V to +15 V
 max. signal level ± 15 V
 Lines up to 20 m long depending on transmission rate.

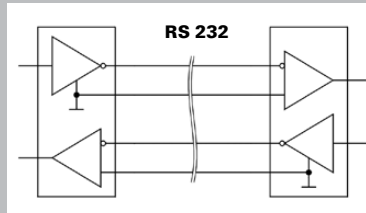

Protection module in terminal housing
 VSSC 6 / RS232

Page 169

RS 422

Serial uni-directional high-speed interface for up to 10 parallel receivers
 Differential voltage signal:
 logic 1 (mark) $A-B < -0.3$ V
 logic 0 (space) $A-B > +0.3$ V
 max. signal level ± 12 V
 Lines up to 1200 m long
 max. data rate 10 Mbit/s

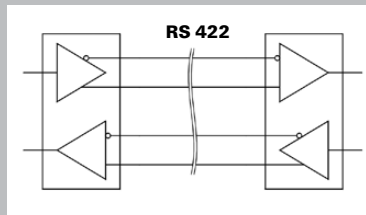

Protection module in plug-in housing
 VSPC / RS485

Page 163

RS485

Serial bi-directional high-speed interface for up to 32 subscribers
 2- or 4-wire system
 Differential voltage signal:
 logic 1 (mark) $A-B < -0.3$ V
 logic 0 (space) $A-B > +0.3$ V
 max. signal level -7 V to +12 V
 Lines up to 1200 m long
 max. data rate 10 Mbit/s

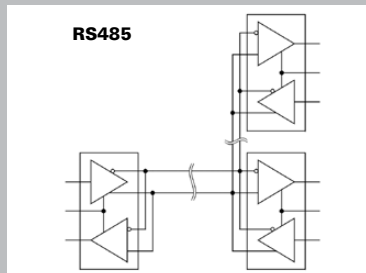

Protection module in plug-in housing
 VSPC / RS485 R

Page 165

Protection module in terminal housing
 VSSC 6 / RS485
 VSSC 6 / RS485 DP

Page 169

VSPC 2CL HF - protection for two analog high-frequency signals

- Optional monitoring function with status indicator and alert function
- Pluggable arrester (impedance-neutral plugging/unplugging without interruption)
- Can be tested with the V-TEST testing device
- Version with floating-earth PE connection for avoiding voltage potential differences
- Space-saving design for 2 analog signals with optional alert function
- Usable in accordance with installation standard IEC 62305
- Tested in accordance with IEC 61643-21:08 D1, C1, C2, C3
- Integrated PE foot, safely discharges up to 20 kA (8/20 μ s) and 2.5 kA (10/350 μ s) to PE

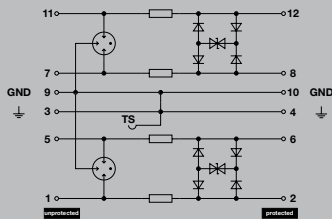
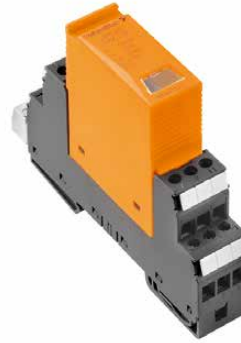

Complete module, direct earthing

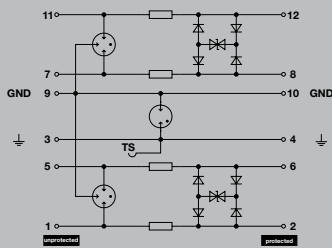

Complete module, indirect earthing

Technical Data

Dielectric strength at FG against PE	≥ 500 V
Volume resistance	2.20
Overload - failure mode	Modus 2
Requirements category acc. to IEC 61643-21	C1, C2, C3, D1
Surge current-carrying capacity C1	< 1 kA 8/20 μ s
Surge current-carrying capacity C2	5 kA 8/20 μ s
Surge current-carrying capacity C3	100 A 10/1000 μ s
Surge current-carrying capacity D1	2.5 kA 10/350 μ s
Discharge current I_b (8/20 μ s) wire-wire/wire-PE/GND-PE	2.5 kA / 2.5 kA / 2.5 kA
Discharge I_{max} (8/20 μ s) wire-wire/wire-PE/GND-PE	10 kA / 2 x 10 kA / 10 kA
Lightning test I_{imp} (10/350 μ s) wire-wire/wire-PE/GND-PE	2.5 kA / 2.5 kA / 2.5 kA
Type of connection	Pluggable in VSPC BASE
Storage temperature	-40 °C...+80 °C
Ambient temperature (operational)	-40 °C...+70 °C
Protection degree	IP 20
Failure probability	
Ages	45
MTTF	2537
SIL in compliance with IEC 61508	3
Approvals	
Approvals	CE; GOSTME25; OEVE; TUEV; UL
Standards	IEC 61643-21

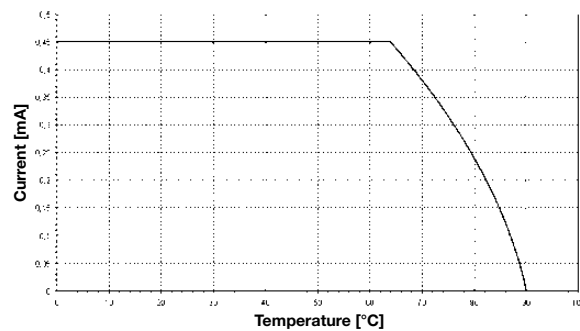

Dimensions of complete module (arrester + base element) no remote sig. contact

Height x width x depth (mm) 90 / 17.8 / 69

Note

The associated VSPC base element should be ordered with this. The dimension information provided refers to the complete module.

Base elements / base to arresters



Ordering Data (for base)

Description	Type	Qty.	Part No.
Base element, direct earthing	VSPC BASE 2CL	1	8924710000
Base element, indirect earthing / floating earth FG	VSPC BASE 2CL FG	1	8924270000

Note

Technical data can be found on page 106.

VSPC 2CL HF - arrester / plug-in components



Technical Data

	VSPC 2CL HF 5 V DC	VSPC 2CL HF 12 V DC	VSPC 2CL HF 24 V DC
Rated voltage (AC)			
Rated voltage (DC)	5 V	12 V	24 V
Max. continuous voltage, U _c (AC)			
Max. continuous voltage, U _c (DC)	6.4 V	15 V	28 V
Rated current	450 mA	450 mA	450 mA
Input attenuation	103 MHz	104 MHz	109 MHz
Pulse-reset capacity	≤ 20 ms	80 ms	≤ 40 ms
Residual voltage, U _p typical	800 V	800 V	800 V
Protection level			
Wire-wire 1 kV/μs, typically	12 V	25 V	45 V
Wire-wire 8/20 μs, typically	12 V	25 V	45 V
Wire-PE 1kV/μs, typically	450 V	450 V	450 V
Wire-PE 8/20 μs, typically	800 V	800 V	800 V

Ordering Data

No function display			
Type	VSPC 2CL HF 5VDC	VSPC 2CL HF 12VDC	VSPC 2CL HF 24VDC
Part No.	8924430000	8924460000	8924510000
Qty.	1 ST	1 ST	1 ST
Note			

VSPC 2CL HF - protection for two analog high-frequency signals with remote alert

- Optional monitoring function with status indicator and alert function
- Pluggable arrester (impedance-neutral plugging/unplugging without interruption)
- Can be tested with the V-TEST testing device
- Version with floating-earth PE connection for avoiding voltage potential differences
- Space-saving design for 2 analog signals with optional alert function
- Usable in accordance with installation standard IEC 62305
- Tested in accordance with IEC 61643-21:08 D1, C1, C2, C3
- Integrated PE foot, safely discharges up to 20 kA (8/20 μ s) and 2.5 kA (10/350 μ s) to PE

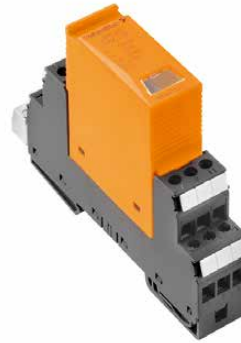

Technical Data

Dielectric strength at FG against PE	500 V
Volume resistance	2.20
Overload - failure mode	Modus 2
Requirements category acc. to IEC 61643-21	C1, C2, C3, D1
Surge current-carrying capacity C1	< 1 kA 8/20 μ s
Surge current-carrying capacity C2	5 kA 8/20 μ s
Surge current-carrying capacity C3	100 A 10/1000 μ s
Surge current-carrying capacity D1	2.5 kA 10/350 μ s
Discharge current I_n (8/20 μ s) wire-wire/wire-PE/GND-PE	2.5 kA / 2.5 kA / 2.5 kA
Discharge I_{max} (8/20 μ s) wire-wire/wire-PE/GND-PE	10 kA / 2 x 10 kA / 10 kA
Lightning test I_{imp} (10/350 μ s) wire-wire/wire-PE/GND-PE	2.5 kA / 2.5 kA / 2.5 kA
Type of connection	Pluggable in VSPC BASE
Storage temperature	-40 °C...+80 °C
Ambient temperature (operational)	-40 °C...+70 °C
Protection degree	IP 20
Failure probability	
Ages	45
MTTF	2537
SIL in compliance with IEC 61508	3
Approvals	
Approvals	CE; GOSTME25; OEVE; TUEV; UL
Standards	IEC 61643-21

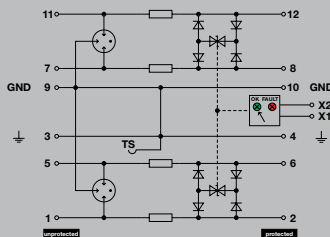

Complete module, direct earthing, with remote alert

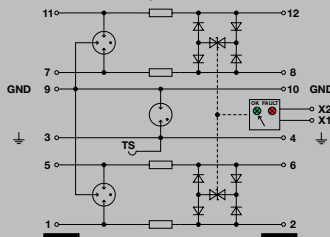

Complete module, indirect earthing, with remote alert

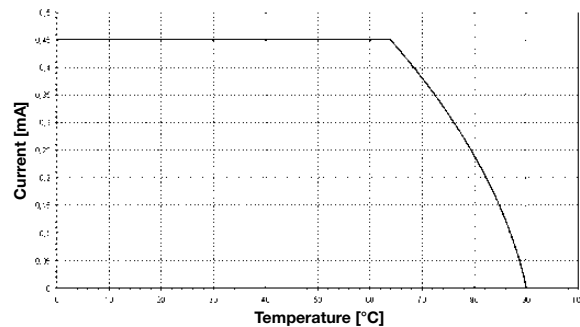

Dimensions of complete module (arrester + base element) with remote signalling (R)

Height x width x depth (mm) 98 / 17.8 / 69

Note

The associated VSPC base element should be ordered with this. The dimension information provided refers to the complete module.

Base elements / base to arresters



Ordering Data (for base)

Description	Type	Qty.	Part No.
Base element, indirect earthing with remote contact	VSPC BASE 2CL FG R	1	8951720000
Base element, direct earthing with remote contact	VSPC BASE 2CL R	1	8951710000

Note

Technical data can be found on page 106. Order with VSPC CONTROL UNIT.

**VSPC 2CL HF - arrester / plug-in components
with remote alert**



Technical Data

	VSPC 2CL HF 5 V DC R	VSPC 2CL HF 12 V DC R	VSPC 2CL HF 24 V DC R
Rated voltage (AC)			
Rated voltage (DC)	5 V	12 V	24 V
Max. continuous voltage, U _c (AC)			
Max. continuous voltage, U _c (DC)	6.4 V	15 V	28 V
Rated current	450 mA	450 mA	450 mA
Signalling contact	U _N 250 V AC 0.1 A 1CO at VSPC R with VSPC CONTROL UNIT	U _N 250 V AC 0.1 A 1CO at VSPC R with VSPC CONTROL UNIT	U _N 250 V AC 0.1 A 1CO at VSPC R with VSPC CONTROL UNIT
Optical function display	green = OK; red = arrester is defective - replace	green = OK; red = arrester is defective - replace	green = OK; red = arrester is defective - replace
Input attenuation	103 MHz	104 MHz	109 MHz
Pulse-reset capacity	≤ 20 ms	≤ 80 ms	≤ 40 ms
Residual voltage, U _p typical	800 V	800 V	800 V
Protection level			
Wire-wire 1 kV/μs, typically	12 V	25 V	45 V
Wire-wire 8/20 μs, typically	12 V	25 V	45 V
Wire-PE 1 kV/μs, typically	450 V	450 V	450 V
Wire-PE 8/20 μs, typically	800 V	800 V	800 V

Ordering Data

With functional display		VSPC 2CL HF 5VDC R	VSPC 2CL HF 12VDC R	VSPC 2CL HF 24VDC R
Type		VSPC 2CL HF 5VDC R	VSPC 2CL HF 12VDC R	VSPC 2CL HF 24VDC R
Part No.		8951680000	8951690000	8951700000
Qty.		1 ST	1 ST	1 ST
Note				

VSPC RS485

- Pluggable arrester (impedance-neutral plugging/unplugging without interruption)
- Can be tested with the V-TEST testing device
- Optional monitoring function with status indicator and alert functions
- Lower residual voltage
- Version with floating-earth PE connection for avoiding voltage potential differences
- Tested in accordance with IEC 61643-21:08
- Integrated PE foot, safely discharges up to 20 kA (8/20 μs) and 2.5 kA (10/350 μs) to PE

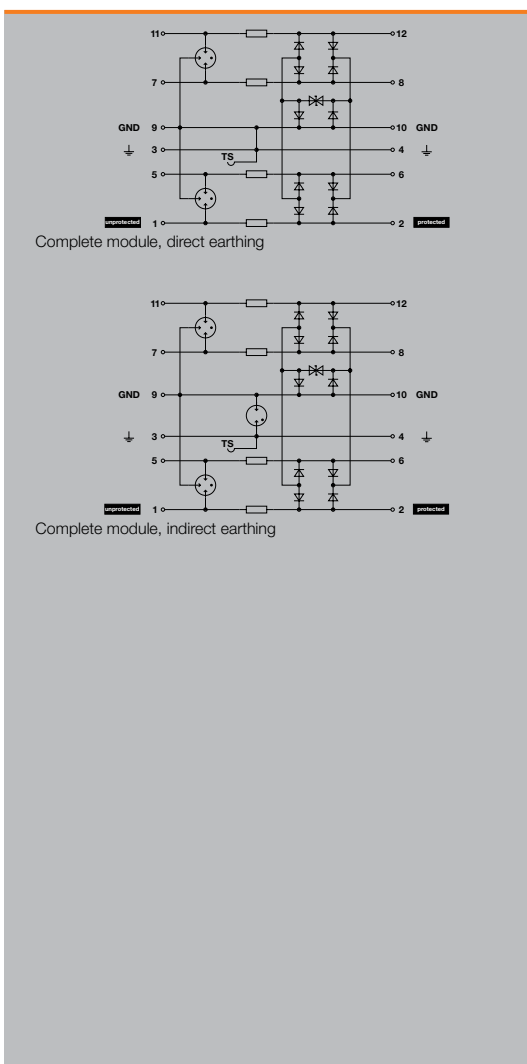
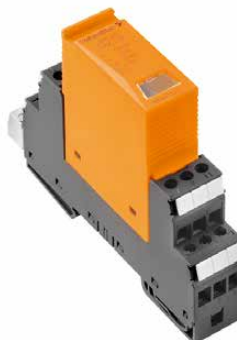

Technical Data

Dielectric strength at FG against PE	≥ 500 V
Volume resistance	2.20 Ω
Overload - failure mode	Modus 2
Requirements category acc. to IEC 61643-21	C1, C2, C3, D1
Surge current-carrying capacity C1	< 1 kA 8/20 μs
Surge current-carrying capacity C2	5 kA 8/20 μs
Surge current-carrying capacity C3	100 A 10/1000 μs
Surge current-carrying capacity D1	2.5 kA 10/350 μs
Discharge current I ₁ (8/20 μs) wire-wire/wire-PE/GND-PE	2.5 kA / 2.5 kA / 2.5 kA
Discharge I _{max} (8/20 μs) wire-wire/wire-PE/GND-PE	10 kA / 2 x 10 kA / 10 kA
Lightning test I _{imp} (10/350 μs) wire-wire/wire-PE/GND-PE	0.2 kA / 2 x 0.2 kA / 0.2 kA
Type of connection	Pluggable in VSPC BASE
Storage temperature	-40 °C...+80 °C
Ambient temperature (operational)	-40 °C...+70 °C
Protection degree	IP 20
Failure probability	
Ages	57
MTTF	2003
SIL in compliance with IEC 61508	3
Approvals	
Approvals	CE; GOSTME25; OEVE; TUEV; UL
Standards	IEC 61643-21

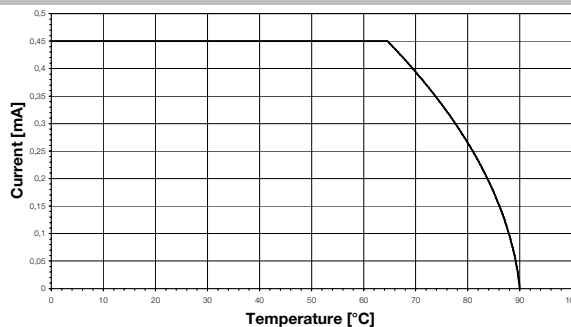

Dimensions of complete module (arrester + base element) no remote sig. contact	
Height x width x depth (mm)	mm 90 / 17.8 / 69
Note	
The associated VSPC base element should be ordered with this. The dimension information provided refers to the complete module.	

Base elements / base to arresters



Ordering Data (for base)

Description	Type	Qty.	Part No.
Base element, direct earthing	VSPC BASE 2CL	1	8924710000
Base element, indirect earthing / floating earth FG	VSPC BASE 2CL FG	1	8924270000

Note Technical data can be found on page 106.

VSPC RS485 - arrester / plug-in components



Technical Data

VSPC RS485 2CH

Rated voltage (AC)	
Rated voltage (DC)	5 V
Max. continuous voltage, U _c (AC)	
Max. continuous voltage, U _c (DC)	6.4 V
Rated current	450 mA
Input attenuation	113.6 MHz
Pulse-reset capacity	≤ 20 ms
Residual voltage, U _r , typical	35 V
Protection level	
Wire-wire 1 kV/μs, typically	10 V
Wire-wire 8/20 μs, typically	15 V
Wire-PE 1kV/μs, typically	10 V
Wire-PE 8/20 μs, typically	35 V

Ordering Data

No function display	
Type	VSPC RS485 2CH
Part No.	8924670000
Qty.	1 ST
Note	

VSPC RS485 with remote alert

- Pluggable arrester (impedance-neutral plugging/unplugging without interruption)
- Can be tested with the V-TEST testing device
- Optional monitoring function with status indicator and alert functions
- Lower residual voltage
- Version with floating-earth PE connection for avoiding voltage potential differences
- Tested in accordance with IEC 61643-21:08
- Integrated PE foot, safely discharges up to 20 kA (8/20 μs) and 2.5 kA (10/350 μs) to PE

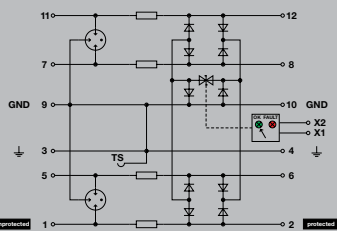

Complete module, direct earthing, with remote alert

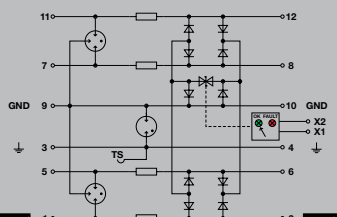

Complete module, indirect earthing, with remote alert

Technical Data

Dielectric strength at FG against PE	≥ 500 V
Volume resistance	2.20 Ω
Overload - failure mode	Modus 2
Requirements category acc. to IEC 61643-21	C1, C2, C3, D1
Surge current-carrying capacity C1	< 1 kA 8/20 μs
Surge current-carrying capacity C2	5 kA 8/20 μs
Surge current-carrying capacity C3	100 A 10/1000 μs
Surge current-carrying capacity D1	2.5 kA 10/350 μs
Discharge current I _d (8/20 μs) wire-wire/wire-PE/GND-PE	2.5 kA / 2.5 kA / 2.5 kA
Discharge I _{max} (8/20 μs) wire-wire/wire-PE/GND-PE	10 kA / 2 x 10 kA / 10 kA
Lightning test I _{imp} (10/350 μs) wire-wire/wire-PE/GND-PE	0.2 kA / 2 x 0.2 kA / 0.2 kA
Type of connection	Pluggable in VSPC BASE
Storage temperature	-40 °C...+80 °C
Ambient temperature (operational)	-40 °C...+70 °C
Protection degree	IP 20
Failure probability	
Ages	90
MTTF	1266
SIL in compliance with IEC 61508	3
Approvals	
Approvals	CE, GOSTME25, OEVE, TUEV, UL
Standards	IEC 61643-21

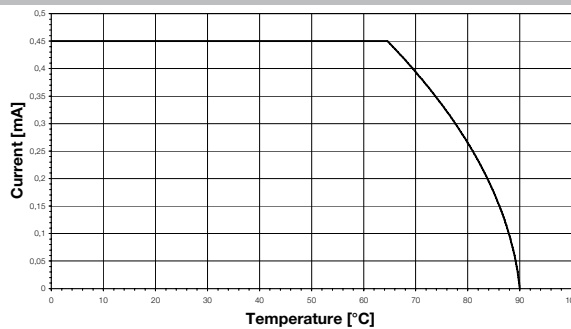

Dimensions of complete module (arrester + base element)	with remote signalling (R)
Height x width x depth (mm)	98 / 17.8 / 69
Note	The associated VSPC base element should be ordered with this. The dimension information provided refers to the complete module.

Base elements / base to arresters



Ordering Data (for base)

Description	Type	Qty.	Part No.
Base element, indirect earthing with remote contact	VSPC BASE 2/4CH FG R	1	8951800000
Base element, direct earthing with remote contact	VSPC BASE 2/4CH R	1	8951790000

Note Technical data can be found on page 107. Order with VSPC CONTROL UNIT.

**VSPC RS485 - arrester / plug-in components
with remote alert**



Technical Data

VSPC RS485 2CH R

Rated voltage (AC)	
Rated voltage (DC)	5 V
Max. continuous voltage, U _c (AC)	
Max. continuous voltage, U _c (DC)	6.4 V
Rated current	450 mA
Signalling contact	U _N 250 V AC 0.1 A 1CO at VSPC R with VSPC CONTROL UNIT
Optical function display	green = OK; red = arrester is defective - replace
Input attenuation	113.6 MHz
Pulse-reset capacity	≤ 20 ms
Residual voltage, U _r typical	35 V
Protection level	
Wire-wire 1 kV/μs, typically	10 V
Wire-wire 8/20 μs, typically	15 V
Wire-PE 1kV/μs, typically	10 V
Wire-PE 8/20 μs, typically	35 V

Ordering Data

With functional display	
Type	VSPC RS485 2CH R
Part No.	8951670000
Qty.	1 ST
Note	

V DATA Cat.6 - surge protection for 8 wires with RJ45 socket

- RJ45 connection
- All 4 lines are protected
- Robust and compact metal housing
- Suitable for Cat.5 (to 100 MHz) and Cat.6 to 250 Mhz (class E)
- Suitable for PoE (IEEE 802.3af) and PoE + (IEEE 802.3at)

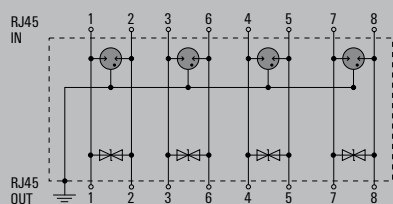

Technical Data

Requirements category acc. to IEC 61643-21	C2, D1
Surge current-carrying capacity C1	
Surge current-carrying capacity C2	5 kA
Surge current-carrying capacity C3	
Surge current-carrying capacity D1	1 kA
Discharge current I_n (8/20 μ s) wire-wire/wire-PE/GND-PE	5 kA / 5 kA / 5 kA
Discharge current I_{max} (8/20 μ s) wire-wire/wire-PE/GND-PE	10 kA / 5 kA
Lightning test I_{imp} (10/350 μ s) wire-wire/wire-PE/GND-PE	1 kA / 1 kA / 1 kA
Type of connection	RJ45-Port
Storage temperature	-40 ... +85 °C
Ambient temperature (operational)	-40 °C...+80 °C
Protection degree	IP 20
Approvals	
Approvals	
Standards	According to IEC61643-21

Dimensions of complete module (arrester + base element)

Height x width x depth (mm) 75 / 19 / 46

Note

Can also be used for Cat.5 applications

V DATA Cat.6 - surge protection for 8 wires with RJ45 socket

Technical Data

V DATA CAT6

Rated voltage (AC)	60 V
Rated voltage (DC)	
Max. continuous voltage, U _c (AC)	
Max. continuous voltage, U _c (DC)	
Rated current	1 A
Input attenuation	250 kHz
Pulse-reset capacity	
Residual voltage, U _r typical	550 V

Ordering Data

Type	V DATA CAT6
Part No.	1348590000
Qty.	1 ST
Note	

VSSC 6AN RS485, RS485 DP and RS232 – for interface signals

- Two-stage surge protection with screw connection for RS422/RS485 data interfaces
- Surge protection in terminal block design
- Modular width of only 6.2 mm
- Space-saving design: 1 signal
- Torx® slotted screw connection
- Can be used in compliance with installation standard IEC 62305
- Tested in accordance with IEC 61643-21: D1, C2, C3
- Integrated PE foot, safely discharges up to 20 kA (8/20 μs) and 2.5 kA (10/350 μs) to PE



Similar to illustration



Similar to illustration

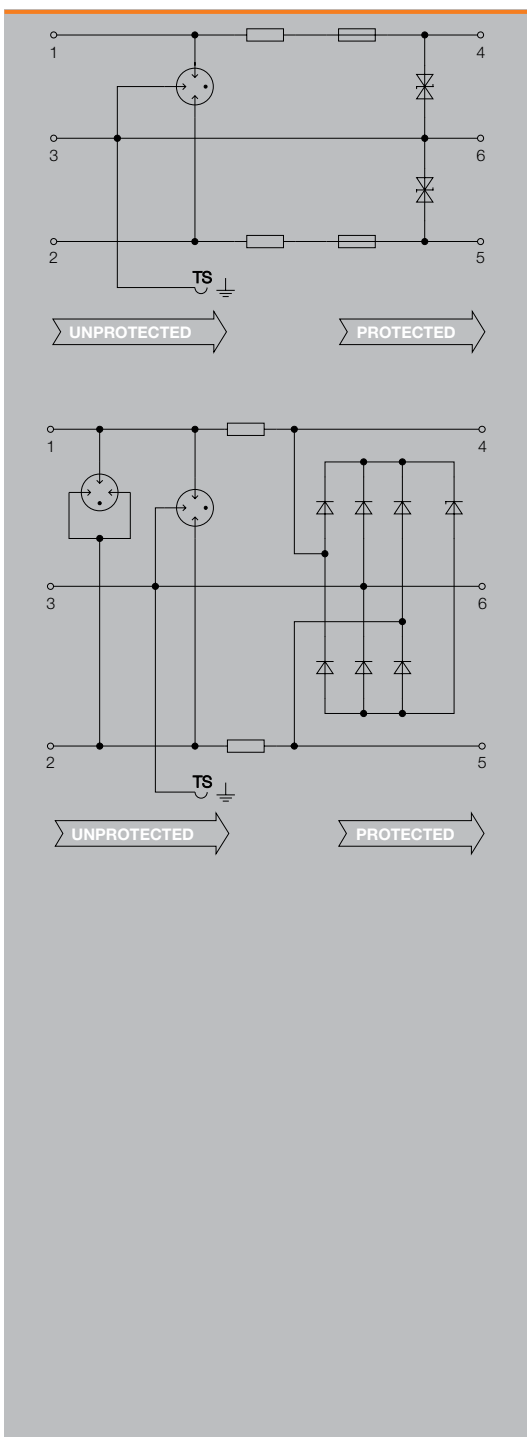

Technical Data

Rated current	500 mA
Volume resistance	1.8 Ω 10 %
Overload - failure mode	Modus 2
Requirements category acc. to IEC 61643-21	C2, C3, D1
Standards	IEC 61643-21
Surge current-carrying capacity C1	
Surge current-carrying capacity C2	2.5 kA 8/20 μs 5 kV 1.2/50 μs
Surge current-carrying capacity C3	10 A 10/1000 μs
Surge current-carrying capacity D1	0.5 kA 10/350 μs
Discharge current I _s (8/20 μs) wire-wire/wire-PE/GND-PE	2.5 kA / 2.5 kA /
Discharge I _{max} (8/20 μs) wire-wire/wire-PE/GND-PE	10 kA / 10 kA /
Lightning test I _{imp} (10/350 μs) wire-wire/wire-PE/GND-PE	/ 0.5 kA /
Storage temperature	-40 °C...+80 °C
Ambient temperature (operational)	-40 °C...+70 °C
Protection degree	IP 20
UL 94 flammability rating	V-0
Connection data	
Type of connection	Screw connection, Torx® T15, Slotted 0.8 x 4
Tightening torque	0.5 Nm
Wire connection cross section, finely stranded, max.	4 mm ²
Wire connection cross-section, finely stranded, min.	0.5 mm ²
Wire cross-section, solid, max.	6 mm ²
Wire cross-section, solid, min.	0.5 mm ²
Wire cross-section, stranded, max.	4 mm ²
Wire cross-section, stranded, min.	0.5 mm ²
Stripping length	10 mm
Mounting rail	TS 35
Failure probability	
λges	60
MTTF	1903
SIL in compliance with IEC 61508	3
Approvals	
Approvals	CE; GOSTME25; OEVE; TUEV; UL; ROHS
Standards	IEC 61643-21

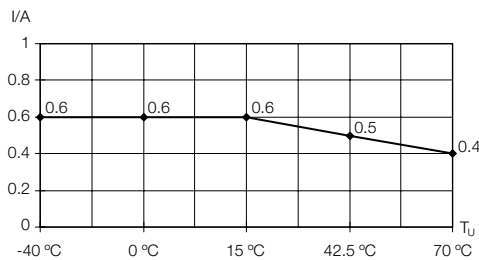

Dimensions	
Height x width x depth (mm)	88.5 / 6.1 / 81

Note

VSSC 6AN RS485, RS485 DP and RS232

Technical Data

	RS485	RS485 DP	RS232
Rated voltage (AC)			
Rated voltage (DC)	12 V	12 V	12 V
Max. continuous voltage, U _c (AC)			
Max. continuous voltage, U _c (DC)	15 V	15 V	15 V
Rated current	500 mA	500 mA	500 mA
Signalling contact	No	No	No
Input attenuation	113.6 MHz	113.6 MHz	1.4 MHz
Pulse-reset capacity	≤ 15 ms	≤ 15 ms	≤ 15 ms
Residual voltage, U _p typical	94 V	94 V	80 V
Protection level			
Wire-wire 1 kV/μs, typically			
Wire-wire 8/20 μs, typically			
Wire-PE 1kV/μs, typically	94 V	94 V	80 V
Wire-PE 8/20 μs, typically			

Ordering Data

	RS485	RS485 DP	RS232
Type	VSSC6 RS485	VSSC6 RS485 DP	VSSC6 RS232
Part No.	1064980000	1065010000	1064990000
Qty.	10 ST	10 ST	10 ST
Note	End plate AP VSSC6 1063110000	End plate AP VSSC6 1063110000	End plate AP VSSC6 1063110000

Surge Protection - MTL



MA15 Series AC & DC Power Protection

The MA15 Series of surge protection devices protects electronic equipment and computer networks against the effects of noise pollution induced in power supplies. MA15 units filter out and suppress the effects of industrial noise and surges caused by lightning, switching devices, thyristor controls, transmission system overloads and power-factor correction circuits.

Product Features:

- 18kA surge protection and RFI filtering
- Protects panel loads up to 15 Amps in series, unlimited Amps in parallel
- Suitable for AC or DC application
- Thermal and short circuit protection
- LED status indication feature
- 10 year product warranty
- UL 1449 3rd Edition

SD Series

SLP Series

Data and Signal Protection

The SD Series are ultra-slim user-friendly devices for protecting electronic equipment and systems against surges on signal and I/O cabling, and the SLP Series provides 20kA power surge protection for process control, equipment systems and distribution panels.

Product Features:

- Range of ATEX Certified intrinsically safe surge protectors
- Ultra-slim and space saving designs; easy installation
- Multistage hybrid protection circuitry - 20kA maximum surge current
- Range of voltage ratings ideal for process I/O applications
- Designed for high bandwidth, low resistance applications; RTD, Public Switch Telephone Network (PSTN) and 3-wire transmitter versions available in SD Series
- Surge protection for two loops or one 4-wire circuit per SLP Series module
- 10 year product warranty

The SD and SLP Series surge protection devices provide unparalleled packing densities, application versatility, proven and reliable hybrid circuitry, simple installation and optional 'loop disconnect' facilities (SD Series). These features make the SD and SLP Series the ultimate surge protection solutions for process control equipment, I/O systems and communications networks.

TP48 Series

Transmitter and Sensor Protection

The TP48 Series of transmitter protectors safeguards electronic process transmitters against induced surges and transients from field cabling. They uniquely provide a level of protection for 2, 3 and 4 wire field-mounted transmitters that greatly exceeds the optional transient protection facilities available from the transmitter manufacturers without any additional wiring, conduit modifications or other expensive extras.

Product Features:

- Easy and direct mounting – simply screw into spare conduit entry
- Intrinsically safe; flameproof to CENELEC standards; ATEX approved
- Parallel connection avoids introduction of resistance into loop
- 10 year product warranty

SD Series

The exceptionally high packing densities are the result of an ultra slim footprint for individual modules, which can double-up as feedback terminals. Each module provides full hybrid surge protection for 2 and 3-wire loop protection.

Modules with a comprehensive range of voltage ratings cover all process related signals such as RTDs, Thermocouples (THCs), 4 - 20mA loops, telemetry outstations, shut-down systems and fire and gas detectors.

The optional loop disconnect featured on the SD07, SD16, SD32 and SD55 modules allows users to perform commissioning and maintenance without removing the surge protection device. In addition, a third connection on the field and safe side of the module is provided for safe termination of shields.

For three wire applications the specially designed SDRTD (Resistance Temperature Detector) and the SD32T3, (for separately powered 4 - 20mA loops) provide full 3-wire protection in a single compact unit. The SD07R3 provides protection of 3-wire pressure transducers on low power circuits.

For higher bandwidth applications, the SDR Series meets the demands of today's highest speed communication systems.

120V and 240V AC versions are available for I/O and power supplies up to three Amps of load current and telephone networks can be protected by the SDPSTN.

All modules are DIN-rail mountable on a TS-35 rail. A comprehensive range of mounting and grounding accessories are available.



SLP Series

The multi-stage hybrid surge protection network at the heart of the SLP uses a combination of solid state electronics and a gas filled discharge tube (GDT) to provide surge protection up to 20kA. This impressive surge protection circuit is designed to exhibit exceptionally low line resistance and adds only a minimal voltage drop to the circuit.

The SLP device does not adversely affect the performance or operation of the loop or combined equipment during operation. The device allows signals to pass with very little attenuation, while diverting surge currents safely to the ground and clamping output voltages to safe levels.

Fully automatic in operation, SLP devices react immediately to ensure that equipment is never exposed to damaging surges between lines or the lines and ground. Reacting instantly, the SLP redirects surges safely to the ground and resets automatically.

The versatile SLP series provides full hybrid surge protection, combining protection for two process loops into one case.

For higher bandwidth applications, the SLP series has been developed to meet the demands of today's highest speed communication systems.



SD Series Guide to applications and selection

The SD Series of signal protection devices includes models for a full range of applications operating at voltages up to 250V AC. The optional fuse/disconnect package provides both fused protection against fault currents and a convenient method of isolating field circuitry from protected circuitry without requiring additional disconnect terminals. The standard fuse (replaceable) is rated 250mA. 50mA fuses are available by special request. Solid links can be used in applications where only the disconnect feature is required.

This feature is important in applications where a signal protection device is used with a bulk power supply feeding multiple loops. The individual fuse module prevents a fault or follow on current on one loop disrupting the power supply to the others. In addition, loops can be removed from the circuit for maintenance or added without requiring additional disconnect terminals. The following guide provides application information for the SD series. For technical information, see page 178.

Analog inputs (high-level)

2-wire transmitters, 4-20mA, conventional and smart

SD32 and SD55 are recommended for use with conventional and smart 4-20mA transmitters (fed by a well-regulated supply), the choice dependent upon the maximum working voltage of the system (32V and 55V respectively). The diagram illustrates an application using the fuse/disconnect. Both models are available in 'X' versions without the optional fuse/disconnect feature.

Analog inputs (low-level)

RTDs, These applications are best served using the SDRTD.

For optimum accuracy, the energizing current should be chosen to ensure the voltage across the RTD does not exceed 1V over the full measurement range. When using a PT100 device, an energizing current of 1mA is recommended.

Photocells and turbine flowmeters

Depending upon the operational voltage, the SD07 or SD16 are the preferred choices for this application. SD07X and SD16X are also suitable.

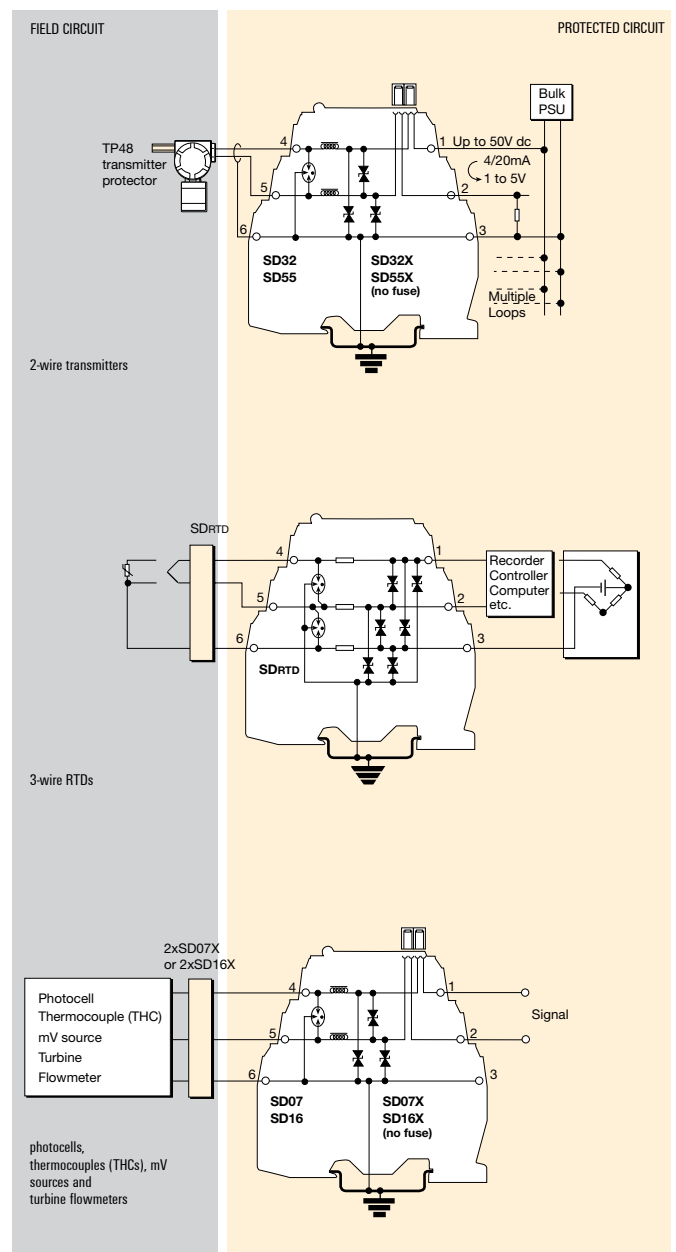

Analog outputs

Controller outputs (I/P converters)

Dependent on the operating voltage, recommendations include the SD16, SD32 and SD55, and the equivalent 'X' versions.

Digital (on/off) inputs - Switches

Suitable signal protection devices include the SD07, SD16, SD32 and SD55 modules, and the equivalent "X" versions. The choice is dependent upon the operating voltage of the system.

Digital (on/off) outputs - Alarms, LEDs, solenoid valves, etc.

The SD32 or SD32X are the recommended choice for this application.

Telemetry Public Switch Telephone Network (PSTN) - Telemetry outstations

The SDPSTN has been designed specifically for the protection of signals transmitted on public switched telephone networks.

AC supplied equipment - PLC, I/O systems

The recommended choice of systems on 110-120V AC is the SD150X ; for 220-240V AC systems, the SD275X is recommended.

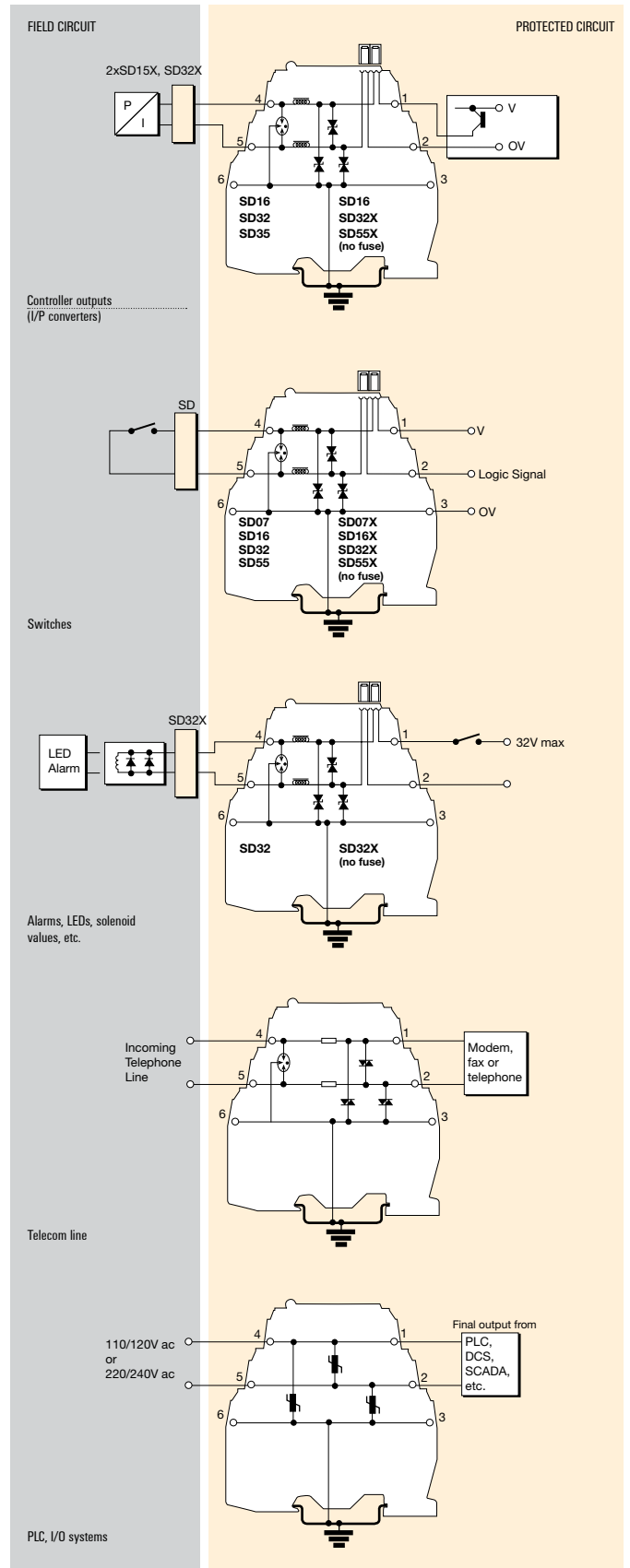

Transmitter and sensor protection

Transmitters and sensors are widely used in highly exposed areas and where lightning damage is common. In many cases, the ideal solution for 2-wire transmitters or sensors is the TP48, which mounts directly onto the transmitter via spare cable entries. Where these entries are not available or 3-wire devices are used, the compact design and simple installation of the SD Series makes it an ideal choice for transmitter protection.

The SDs within the junction box should be installed as close as possible to the sensor or transmitter they are protecting, but no further than one meter away. A bond is required from the general mass of steelwork to the sensor or transmitter housing, using either a flat short braid or a cable at least 0.16 inch² (4mm²) cross sectional area. In most instances, this bond is made automatically by fixing the metallic transmitter housing to the plant structure and ensures the voltage difference between the signal conductors and the transmitter housing is below the transmitter's insulation rating. Please note that the transmitters or sensors are connected to the SD protected equipment terminals, not the field cables.

2-wire transmitters or sensors

4-20mA transmitters - conventional and smart

The SD16X, SD32X and SD55X are an excellent alternative if the TP48 is not an acceptable solution, either because of technical suitability or mounting difficulties.

3-wire transmitters or sensors

Vibration Sensors and 4-20mA loop process control systems generally require three wire connections when powered from an external source. This may be accomplished in one unit by using the SD32T3 3-terminal Surge Protection Device (SPD). Because the SD32T3 protects all three conductors within the same unit, higher protection is achieved because the SPD hybrid circuitry is common to all three wires. The SD07R3 is also suitable for the protection of 3-wire pressure transducers on low power circuits.

4-wire transmitters or sensors - Flow meters, level detectors, etc.

4-wire systems such as level detectors require two SDs, one for the supply and the other for the transmitter output. Generally the voltages across the pairs are similar, so the recommended choice is a pair of SD16X, SD32X or SD55Xs. Dependent upon the supply voltage, AC powered transmitters should be protected with an SD150X for the supply inputs.

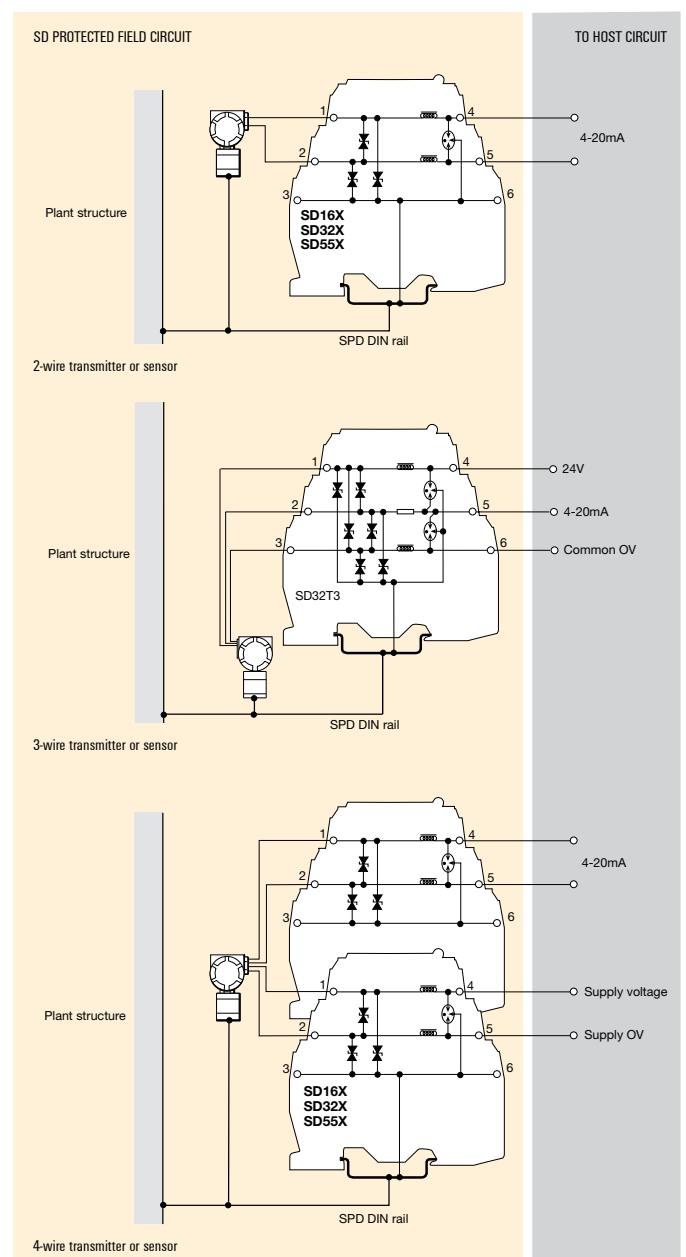

Communication systems protection

High-speed data links between buildings or one part of a plant to another have become more common with the widespread use of smart transmitters and the increase in remote installations. The SD Series has an SPD suitable for all process I/O applications with a choice of low resistance units, high bandwidth and a variety of voltage ranges. Featuring an extremely high bandwidth, the SDR Series is designed to meet the requirements for high speed data links.

Communication systems

RS232, RS422, RS485

The recommended choice for these applications is the SD16R or SD32R depending on the maximum driver signal.

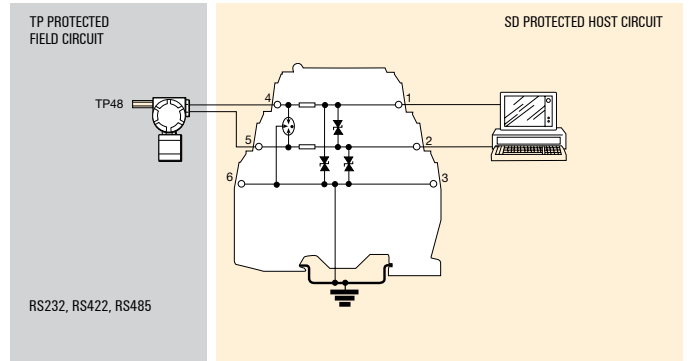

Bus powered systems

There are a variety of bus powered systems specially designed for the process industry. The ideal surge protection device for these systems is the SD32R, with a very high bandwidth and modest in-line resistance.

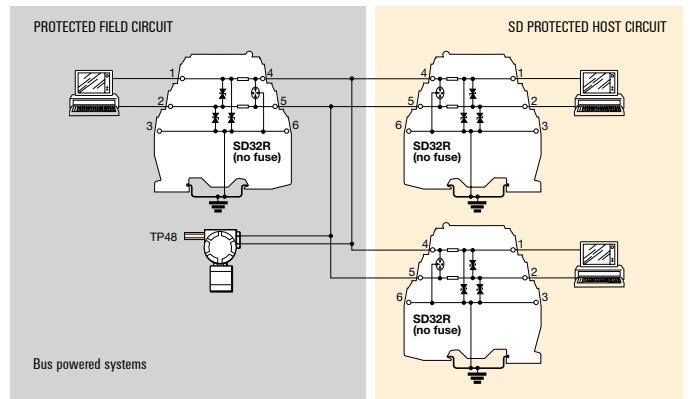

Typical Applications

Table 1 shows suitable SD devices for different applications. In some applications alternative devices may be used, for example, where lower in-line resistance or a higher voltage power supply is used.

MTL Surge Technologies has operationally tested the recommended SD Series units with the representative highways listed. However, no formal approval for their use in these systems has been sought from the respective bodies.

Table 1

Application	Preferred Part No.	Alternate Part No.
Allen Bradley Data Highway Plus	SD16R	
Foundation Fieldbus		
31.25kbits/s voltage mode	SD32R	
1.0/2.5 Mbits/s	SD55R	
HART	SD32X	SD32, SD32R
Honeywell DE	SD32X	SD32, SD32R
LonWorks		
FFT-10	SD32R	
LPT-10	SD55R	
TP-78	SD07R	
IS78†	SD32R	
Modbus & Modbus Plus (RS485)	SD16R	
PROFIBUS		
DP	SD32R	
PA (IEC 1158, 31.25 kbits/s)	SD32R	
RS232	SD16	SD16X
RS422	SD07R	
RS423	SD07R	
RS485	SD07R	
WorldRP (IEC 1158)		
31.25 kbits/s voltage mode	SD32R	
1.0/2.5 Mbits/s	SD55R	

Hazardous area applications

Zone 0/Zone 1

The dangers from lightning induced sparking in Zone 0 are considered real enough to require preventative measures. IEC 60079-14 (1996-12) Electrical apparatus for explosive gas atmospheres Part 14: Electrical installations in hazardous areas (other than mines) stresses the importance of SPDs in hazardous areas. An outdoor installation where there is a high likelihood of both lightning induced transients and combustible gases requires the installation of SPDs to prevent possible ignition of the gases. Areas seen particularly at risk include flammable liquid storage tanks, effluent treatment plants, distillation columns in petrochemical works and gas pipelines.

SPDs for transmitter protection should be installed in Zone 1, sufficiently close to the Zone 0 boundary to prevent high voltages entering Zone 0. The distance from the SPD to Zone 0 should be less than 36" where possible. In practice the SPD would normally be mounted on the transmitter or sensor housing which usually lies in Zone 1 and is very close to Zone 0. Because there is only a very small free volume, the SD series is suitable for mounting in flameproof or explosion proof enclosures.

Zone 2

The SD series is suitable for protecting electrical circuits in Division 2, Zone 2 and can be used without affecting the safety aspects of the circuit. Non-incendive (low-current) circuits can be protected using any SD series unit mounted in either the safe or hazardous area, including those with the fuse disconnects facility. Non-arcing (high current) circuits can also be protected, however SPDs with the fuse disconnect facility may only be mounted in the safe area. For use in these circuits the units must be mounted in a suitable enclosure. In most cases the minimum requirements are IP54 and 7Nm resistance to impact. The SD series is self certified by MTL Surge Technologies as suitable for this purpose.

Certification

Introducing surge protection into Intrinsically Safe (IS) circuits is trouble free as long as the current and power parameters are not exceeded. In the SD series, the SD**X, SD**R, SD**R3, SDRTD and SD**T3 all have ATEX certification for use in IS circuits located in Zones 0, 1 or 2. The certification parameters for the SD**X and SD**T3 are:

EEx ia IIC T4, Li = 0.22mH
$I_n = 260\text{mA}$ for U_i up to 20V
$I_n = 175\text{mA}$ for U_i up to 26V
$I_n = 140\text{mA}$ for U_i up to 28V
$I_n = 65\text{mA}$ for U_i up to 60V

The certification parameters for the SD**R, SD**R3 and SDRTD are:

EEx ia IIC T4, Li = 0
$I_n = 260\text{mA}$ for U_i up to 60V

The power rating for each of the above is dependent on the table shown below.

$P_n = 1\text{W}$ (-30°C to +75°C)
$P_n = 1.2\text{W}$ (-30°C to +60°C)
$P_n = 1.3\text{W}$ (-30°C to +40°C)

The SD** series are classified as simple apparatus and are intended for use in Zone 2 or safe areas only, because their fuses are not fully encapsulated.

Installation

Positioning

The SDs should be mounted on the field wiring side to ensure that any surges entering from the field do not damage any intrinsically safe barriers or galvanic isolators in the system. The SDs and intrinsically safe interface should be mounted close to each other but on separate DIN-rails in order to maintain the required 1.97" (50mm) clearance between safe area and hazardous area terminals of the IS interface.

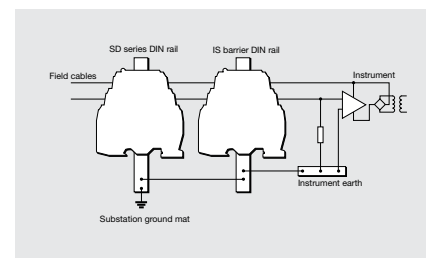

Grounding

The recommended grounding for field-mounted devices has been illustrated previously. The grounding at the control panel is more critical as there are usually a number of grounding systems, each with their own requirements. The grounding system illustrated here replaces the instrument 0V bond, the control system PSU bond and the IS ground with one single ground connection to meet all the design requirements and give the most effective protection against the effects of lightning induced surges.

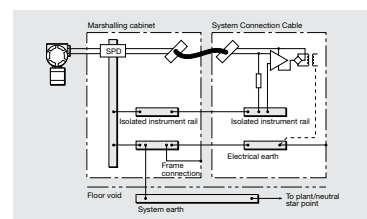

In all installations utilizing safety related apparatus, consideration should be given to protecting the system supply and any long communication cable.

Specifications SD Series

All figures typical at 77°F (25°C) unless otherwise stated

Protection	Full hybrid line to line Each line to screen/ground
Max. discharge surge current (I_{max}) (8/20μs)	20kA (8/20μs) 6.5kA (SD150X and SD275X only)
Nominal discharge surge current (I_{sn})	3kA (8/20μs)
Lightning impulse current (I_{imp}) (10/350μs)	2.8kA 1.0kA (SD150X and SD275X only)
Response time	<1ns
RTD resistance range (SDRTD)	10 to 1500Ω
Degradation accuracy (SDRTD at 1mA)	0.1% (RTD resistance > 100Ω) 0.1W (RTD resistance < 100Ω)
Ambient temperature	-40°C to +80°C / -40°F to 176°F working -40°C to +80°C / -40°F to 176°F storage For IS working applications: P ₁ = 1.0W (-30°C to +75°C / -22°F to 167°F) P ₁ = 1.2W (-30°C to +60°C / -22°F to 140°F) P ₁ = 1.3W (-30°C to +40°C / -22°F to 104°F)
Humidity	5 to 95% RH (non-condensing)
Category tested	A2, B2, C1, C2, C3
Overstressed fault mode I_n=3kA	12kA 9kA (SD150X and SD275X only)
Impulse durability (8/20μs)	10kA 6.5kA (SD150X and SD275X only)
Terminals	2.5mm ² (12 AWG)
Mounting	T-section DIN-rail 35 x 7.5 or 35 x 15mm rail (1.38" x 0.3" x 0.6")
Weight	70g approximately (2.5oz)
Case flammability	UL94 V-2
AC durability	1A _{rms} 5T
Service conditions	80kPa - 160kPa 5% - 95% RH
EMC compliance	To Generic Immunity Standards, EN 61326-1, part 2 for industrial environments
R&TTE compliance	EN 41003:1999 EN 60950-1:2006 (not applicable to SD150X and SD275X)
LVD compliance	SD150X & SD275X EN 60950-1:2006 EN 61010:2010 SDPSTN EN 41003:1999
IEC compliance	EN 61643-21:2001
ANSI/IEEE testing	C62.41-1-2002 C62.41-2-2002 C62.45-2002

Approvals

(Authority) Country	Standard	Certificate/File No.	Approved for	Product
Baseefa [ATEX] (EU)	EN 60079-0:2009 EN 60079-11:2007	Baseefa02ATEX0211X	Ex ia IIC T4 Ga Ta = -30°C to See Schedule	SD07X, SD16X, SD32X, SD55X, SD07R, SD16R, SD32R, SD55R, SDRTD, SD32T3, SD07R3, SD16R3, SD32R3, SD55R3
MTL (EU)	EN 60079-15:2005 EN 60079-14:2003	MTL03ATEX0755X	Ex nA IIC T4	SD07, SD16, SD32, SD55, SD07X, SD16X, SD32X, SD55X, SD07R, SD16R, SD32R, SD55R, SD32T3, SD07R3, SD16R3, SD32R3, SD55R3, SDRTD
Baseefa [IECEX] (International)	IEC 60079-0: 2007-10 IEC 60079-11: 2006	IECEX BAS 12.0003X	Ex ia IIC T4 Ga	SD07X, SD16X, SD32X, SD55X, SD07R, SD16R, SD32R, SD55R, SDRTD, SD32T3, SD07R3, SD16R3, SD32R3, SD55R3
CSA/C/US (Canada, USA)	CSA C22.2 No. 0-M1991 CSA C22.2 No. 157-M1992 UL 913, 5th edition CSA C22.2 No. 142-M1987 CSA C22.2 No. 213-M1987	LR 36637	EEx ia Class 1, Groups A, B C and D, T4 Class 1, Div 2 Groups A,B,C, D T4	SD07, SD16, SD32, SD55, SD07X, SD55X, SD07R, SD16R, SD32R, SD55R, SDRTD, SD32T3, SD07R3, SD16R3, SD32R3, SD55R3
UL (USA)	UL 497B Listed	E220693	Isolated loop communication circuits	SD07, SD16, SD32, SD55, SD07X, SD16X, SD32X, SD55X, SD07R, SD16R, SD32R, SD55R, SD07R3, SD16R3, SD32R3, SD55R3, SD32T3, SD55T3, SD07X3, SD16X3, SD32X3, SD55X3, SDRTD
Austel (Australia)	AS/NZ3548:1995 AS/NZS4117:1996 TS001: 1997	—	Private Wire	SD07R

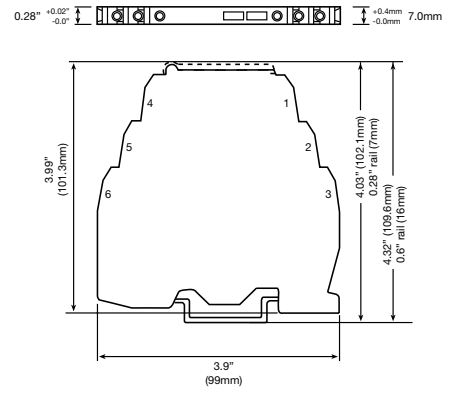

Technical Data

Nominal voltage+(U _n) Vdc	7	16	32	55
Nominal voltage+(U _n) Vac	5	11	22	38
Nominal current (I _n) mA	250	250	250	250
Series resistance Ω/line	4.2	4.2	4.2	4.2
Max. leakage current μA	500	5	5	5
Rated voltage (MCOV) U _c	7.7	17	36	62
Voltage protection level (U _p) @1kV/μs V	<12	<25	<45	<90
Residual voltage @ I _{sn} V	30	40	60	100
Bandwidth frequency f _G	25 kHz	25 kHz	25 kHz	25 kHz
Special feature	Fuse disconnect	Fuse disconnect	Fuse disconnect	Fuse disconnect

	SD07	SD16	SD32	SD55
Nominal voltage+(U _n) Vdc	7	16	32	55
Nominal voltage+(U _n) Vac	5	11	22	38
Nominal current (I _n) mA	250	250	250	250
Series resistance Ω/line	4.2	4.2	4.2	4.2
Max. leakage current μA	500	5	5	5
Rated voltage (MCOV) U _c	7.7	17	36	62
Voltage protection level (U _p) @1kV/μs V	<12	<25	<45	<90
Residual voltage @ I _{sn} V	30	40	60	100
Bandwidth frequency f _G	25 kHz	25 kHz	25 kHz	25 kHz
Special feature	Fuse disconnect	Fuse disconnect	Fuse disconnect	Fuse disconnect

Technical Data

Nominal voltage+(U _n) Vdc	7	16	32	55
Nominal voltage+(U _n) Vac	5	11	22	38
Nominal current (I _n) mA	400	400	400	400
Series resistance Ω/line	2.7	4.7	10	10
Max. leakage current μA	500	5	5	5
Rated voltage (MCOV) U _c	7.7	17	36	62
Voltage protection level (U _p) @1kV/μs V	<12	<25	<45	<90
Residual voltage @ I _{sn} V	30	40	60	100
Bandwidth frequency f _G	50 MHz	50 MHz	50 MHz	50 MHz
Special feature	High bandwidth	High bandwidth	High bandwidth	High bandwidth

	SD07R	SD16R	SD32R	SD55R
Nominal voltage+(U _n) Vdc	7	16	32	55
Nominal voltage+(U _n) Vac	5	11	22	38
Nominal current (I _n) mA	400	400	400	400
Series resistance Ω/line	2.7	4.7	10	10
Max. leakage current μA	500	5	5	5
Rated voltage (MCOV) U _c	7.7	17	36	62
Voltage protection level (U _p) @1kV/μs V	<12	<25	<45	<90
Residual voltage @ I _{sn} V	30	40	60	100
Bandwidth frequency f _G	50 MHz	50 MHz	50 MHz	50 MHz
Special feature	High bandwidth	High bandwidth	High bandwidth	High bandwidth

Technical Data	SD07X	SD16X	D32X	SD55X
Nominal voltage+(U_n) Vdc	7	16	32	55
Nominal voltage+(U_n) Vac	5	11	22	38
Nominal current (I_n) mA	400	400	400	400
Series resistance Ω /line	2.2	2.2	2.2	2.2
Max. leakage current μ A	500	5	5	5
Rated voltage (MCOV) U_c	7.7	17	36	62
Voltage protection level (U_p) @1kV/ μ s V	<12	<25	<45	<90
Residual voltage @ i_{sn} V	30	40	60	100
Bandwidth frequency f _G	25 kHz	25 kHz	25 kHz	25 kHz
Special feature	Low resistance	Low resistance	Low resistance	Low resistance

Technical Data	SD32T3	SD07R3	SD16R3	SD32R3	SD55R3
Nominal voltage+(U_n) Vdc	32	7	16	32	55
Nominal voltage+(U_n) Vac	22	5	11	22	38
Nominal current (I_n) mA	400	400	400	400	400
Series resistance Ω /line	2.2	2.7	4.7	10	10
Max. leakage current μ A	5	500	5	5	5
Rated voltage (MCOV) U_c	36	7.7	17	36	62
Voltage protection level (U_p) @1kV/ μ s V	<45	<12	<25	<45	<90
Residual voltage @ i_{sn} V	75	30	40	60	100
Bandwidth frequency f _G	720 kHz	50 MHz	50 MHz	50 MHz	50 MHz
Special feature	3 terminal	3 terminal	3 terminal	3 terminal	3 terminal

Technical Data	SDRTD	SDPSTN	SD150X	SD275X
Nominal voltage+(U_n) Vdc	1	162	150	320
Nominal voltage+(U_n) Vac	0.75	114	120	240
Nominal current (I_n) mA	10	550	3A	3A
Series resistance Ω /line	2.7	4.7	0.1	0.1
Max. leakage current μ A	0.3	5	50 ac rms; 170 ac	50 ac rms; 360 ac
Rated voltage (MCOV) U_c	5	175	130 ac rms	275 ac rms
Voltage protection level (U_p) @1kV/ μ s V	<12	<200	<400	<700
Residual voltage @ i_{sn} V	30	235	450	850
Bandwidth frequency f _G	50 MHz	4 MHz	--	--
Special feature	3-wire RTD	PSNT	High current	High current

Ordering Data

Description	Type	Part No.
Mounting Accessories	Rail Holder	0494920000
Grounding/Ground Rail Accessories	Ground terminal, DIN-rail mounted	1010100000
Accessories (Replacement)	Replacement fuse pack 250mA standard	SDF25



Specifications SLP Series

All figures typical at 77°F (25°C) unless otherwise stated

Maximum surge current	20kA (8/20µs waveform) per line
Leakage Current	<1µA @ working voltage
Maximum rated load current	1.50A
Loop resistance	2 Ohm
Capacitance	Line to Line - 60pF
Bandwidth	-0.1db @9kHz - 37MHz -3dB @50MHz
Response time	<1ns
Ambient temperature	-40°C to +70°C (working) -40°F to +158°F (working) -40°C to +80°C (storage) -40°F to +176°F (storage)
Humidity	5 to 95% RH (non-condensing)
Terminals	2.5mm ² (12 AWG)
Electrical connections	Plug/header screw terminal strip
Mounting	T-section DIN-rail (35 x 15mm rail)
Weight	5oz (140g approximately)
Case flammability	UL94-V0
EMC compliance	BS EN 60950:1992 BS EN 61000-6-2:1999 BS EN 61010-1:1993 BS EN 61000-4-5:2006

Dimensions

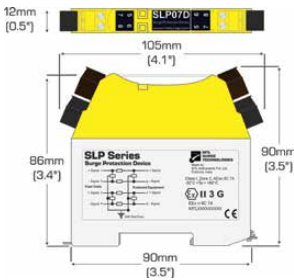

Connections

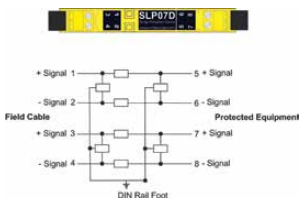

Approvals

Country (Authority)	Standard	Certificate/File No.	Approved for	Product
Europe (Baseefa)	EN 50014:1997 + A1 & A2 EN 50020:2002 EN 60079-26:2004	Baseefa04ATEX0303X	EEx ia IIC T4	SLP07D, SLP16D, SLP32D
Europe (MTL)	BS EN 50014:1998 BS EN 50021:1999 EN 60079-15:2003	MTL03ATEX0377X	EEx n IIC T4	SLP07D, SLP16D, SLP32D
USA (FM)	Class Nos. 3600 (1998), 3610 (2010), 3611 (1999), 3615 (1989), 3810 incl. Supp 1 (1995-07 (1989-03), ANSI/NEMA 250 (1991) ANSI/ISA 60079-0 (2009 ANSI/ISA 60079-11 (2009) ISA-S12.0.01 (1999)	3011208	IS/I/1/A-D I/O/AEx ia IIC I/O/AEx ia IIB NI/I/2/A-D NI/I/2/IIC	SLP07D, SLP16D, SLP32D
Canada (FM)	C22.2 No. 213, 142, 94, 157, 30 ANSI/NEMA 250 CAN/CSA-E79-0 CAN/CSA-E79-11	3025374C	IS/I/1/A-D I/O/AEx ia IIC I/O/AEx ia IIB NI/I/2/A-D NI/I/2/IIC	SLP07D, SLP16D, SLP32D

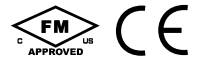

Technical Data

	SLP07D	SLP16D	SLP32D
Nominal voltage U_n	7V	16V	24V
Rated voltage (MCOV) U_c	8V	18V	32V
Nominal current I_n	1.50A	1.50A	1.50A
Nominal discharge current (8/20µs) i_{sn}	3kA	3kA	3kA
Max discharge current (8/20µs) I_{max}	20kA	20kA	20kA
Lightning impulse current (10/350µs) I_{imp}	2.5kA	2.5kA	2.5kA
Residual voltage (@ i_{sn}) U_p	10V	23V	40V
Voltage protection level (@ 1kV/µs) U_p	<8V	<18V	<38V
Bandwidth f_c	50MHz	50MHz	50MHz
Capitance C	60pF	60pF	60pF
Series resistance R	1.0	1.0	1.0
Operating Temperature Range	-40°C to +80°C	-40°C to +80°C	-40°C to +80°C
Category tested	A2, B2, C1, C2, C3, D1	A2, B2, C1, C2, C3, D1	A2, B2, C1, C2, C3, D1
Overstressed fault mode in-3kA	22kA	22kA	22kA
Impulse durability (8/20µs)	10kA	10kA	10kA
Degree of protection	IP20	IP20	IP20
AC durability	1A _{rms} , 5T	1A _{rms} , 5T	1A _{rms} , 5T
Service conditions	80kPa - 160kPa 5% - 95% RH	80kPa - 160kPa 5% - 95% RH	80kPa - 160kPa 5% - 95% RH

Installation

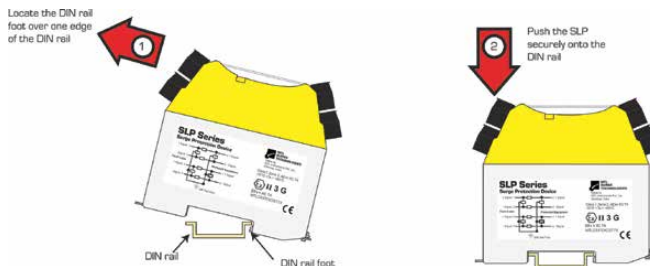



MA15 Series

Industrial control systems utilizing programmable logic controllers (plc) and industrial computers are particularly vulnerable due to the aggressive electrical environments for which they are intended, such as process plants, factories and water treatment sites.

Although industrial computers and PLCs are designed to be rugged, the extra protection provided by the DIN-rail mounting MA15 units is critical. Ideally suited for protecting panel mounted equipment and typically used in the controls section of a motor control center (MCC), the MA15 range provides surge and RFI protected power.

With a unique 'three-stage' combination of protection elements, these units suppress conducted RFI and voltage surges. The circuit elements are: (1) surge clipping components to absorb transient surges that may otherwise damage equipment, (2) a filter to suppress noise in the system and, (3) ring suppression. Ring suppression prevents surges causing the filter to 'ring' (oscillate) under low load conditions - an effect that actually accentuates interference in most commercially available filters.

Suitable for AC or DC application, MA15 units reduce both electromagnetic emissions and the susceptibility of the associated equipment to emissions from other sources. MA15 devices also offer installation flexibility. To protect circuits rated 15A or less, MA15 devices should be installed in series. To protect higher current circuits, simply install the MA15 in parallel.

LED status indication is standard with the MA15 units. Thermal fusing is also incorporated into each 18kA rated device as an additional safety feature. MA15 modules also offer short circuit protection for added safety.

MA15 devices are UL 1449 Recognized Components (certified by UL for both US and Canadian requirements) and exceed the requirements of IEC 61000-4-5. As MA15 units suppress conducted RFI and voltage surges they enable associated equipment to comply with this aspect of European 'CE' mark standards.

Specifications MA15 Series

All figures typical at 77°F (25°C) unless otherwise stated

Maximum surge current:		
18kA (8/20µs) per mode		
Leakage current		
<0.3mA		
Maximum continuous operating current		
120V @ 15A, 240V @ 10A series connection		
Unlimited Amps in parallel		
Working voltage		
	AC	DC
MA15/D/1/SI	120V, 47-63Hz	140V
MA15/D/1TT/SI	120V, 47-63Hz	140V
MA15/D/2/SI2	40V, 47-63Hz	280V
MA15/D/2TT/L	240V, 47-63Hz	280V
Maximum continuous operating voltage		
25% above nominal		
Limiting voltage		Let through voltage
@ 500A ring		
120V/140V versions		295V
240V/280V versions		356V
@ 500A 8/20µs		
120V/140V versions		320V
240V/280V versions		800V
@ 3kA 8/20µs		
120V/140V versions		396V
240V/280V versions		975V
@ 10kA 8/20µs		
120V/140V versions		585V
240V/280V versions		1210V
Maximum attenuation (typical): -55dB @ 100MHz		
Modes protected: L-N, L-E, N-E		
Ambient temperature limits		
-40°F to +185°F (working)		
-40°C to +85°C (working)		
Humidity		
95% RH (non-condensing)		
Casing		
Polymide-PA, with G- or T-section		
(Top-hat) DIN-rail mounting foot		
UL94-V0		
Connectors		
Screw terminal		
Terminals		
0.1 inch ² (2.5mm ²) 12 AWG		
Mounting		
G- or T-section ("Top-hat") or		
1.4 inch (35mm) DIN-rail		
Weight		
3.53oz (100g)		
EMC compliance		
BS EN 60950 : 1992		
BS EN 61000-6-2 : 1999		
LED Indication		
Green LED on Protection present		
Green LED off Internal failure		

Ordering Data

AC	DC	Part No.
120V, 47-63Hz	140V	MA15D1SI
240V, 47-63Hz	280V	MA15D2SI

Approvals

Country (Authority)	Standard	Approved for	Product No.
United States	UL 1449	AC Power Product	MA15D1SI, MA15D2SI
Canada	Recognized Component		
United States	UL 1449	Hazardous Locations	MA15D1SI, MA15D2SI
Canada	Recognized Component	Class I, Division 2	
	UL 1604	Groups A, B, C and D	

Dimensions

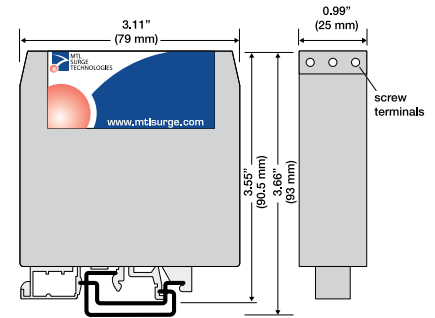

Installation

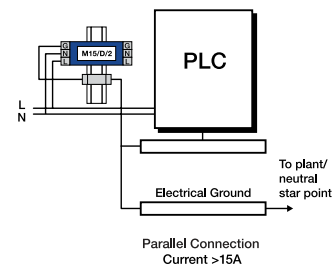
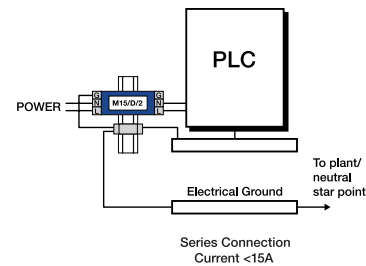

The grounding of the surge protector and the protected equipment is very important and, if possible, should be accomplished as illustrated.

Please note that the unit is marked Line and Load and it is important that the unit is installed with the Line side connected to the incoming power and the Load connected to the equipment to be protected. For parallel application however, the Line side is connected to the incoming power and the Load left unconnected.



The TP Series protection network consists of high-power, solid-state electronics and a gas-filled discharge tube capable of diverting 20kA impulses. The whole unit is encased in an ANSI 316 stainless steel housing, threaded for the common conduit entries used on process transmitters. Versions are available for 1/2" NPT, 20mm ISO, and G1/2" (BSP 1/2 inch) threaded entries.

Specifications TP Series

All figures typical at 77°F (25°C) unless otherwise stated

Maximum surge current	20kA peak current (8/20µs waveform)
Leakage current	Less than 10µA at maximum working voltage
Working voltage	35 VDC maximum
Bandwidth	1MHz
Resistance	No resistance introduced into loop
Ambient temperature limits	-40°C to +80°C (working) -40°F to +185°F (working) -40°C to +85°C (storage) -40°F to +185°F (storage)
Humidity	5% to 95% RH (non-condensing)
Electrical connections	
TP48	3 flying leads (line 1, line 2 & ground)
TP48 3 Wire	4 flying leads (+ve, -ve, signal & ground)
TP48 4 Wire	5 flying leads (+ve, -ve, signal +ve, signal -ve, ground)
	Wire size 32/0.2 (1.0mm ² , 18 AWG) Lead length 250mm (minimum)
Casing	ANSI 316 stainless steel hexagonal barstock, male thread
Threads	TP48-3-N & TP48-4-N 1/2" NPT TP48-3-I & TP48-4-I 20mm ISO (M20 x 1.5) TP48-3-G & TP48-4-G G 1/2" (BSP 1/2")
Weight	175g (6.2oz)
Dimensions	See Figure 1
EMC compliance	To Generic Immunity Standards EN50082, part 2 for industrial environments
Electrical safety	EEx ia IIC T4, Ceq=0, Leq=0; the unit can be connected without further certification into any intrinsically safe loop with open circuit voltage <60V and input power <1.2W. EEx d IIC T4; the unit is apparatus-approved to flame proof (explosionproof) standards, and can be fitted into a similarly approved housing.

Dimensions

Figure 1

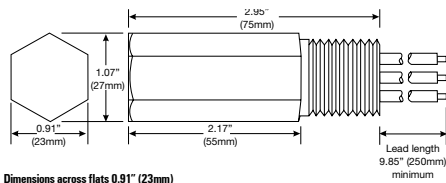

Approvals

Country (Authority)	Standard	Certificate/File No.	Approved for	Product
EC (BASEEFA)	EN 50014:1997 + Amendments 1 & 2 EN 50020:1994, EN 50284:1999	BASEEFA04ATEX0251X	EEx ia IIC T6 (Tamb = -40 to 60°C) EEx ia IIC T5 (Tamb = -40 to 85°C) EEx ia IIC T4 (Tamb = -40 to 60°C)	TP48-X-Y-Z
EC (BASEEFA)	EN 50014:1997 + Amendments 1 & 2 EN 50018:2000 + Amendment 1	BASEEFA04ATEX0251X	EEx d IIC T6 (Tamb = -40 to 60°C) EEx d IIC T5 (Tamb = -40 to 80°C) EEx d IIC T4 (Tamb = -40 to 85°C)	TP48-X-Y-Z
Atex Directive 94/9/EC	BS EN 50021:1999	TML02ATEX0032X	Ex n II T6 (-40°C<Tamb<+60°C) EEx n II T5 (-40°C<Tamb<+85°C)	TP48-X-Y-Z
USA (FM)	Class Nos. 3600 (1998), 3610 (1999), 3611 (1999), 3615 (1989), 3810 incl. Supp 1 (1995-07) (1989-03), ANSI/NEMA 250 (1991), ISA-S12.0.01 (1999)	3022293	Intrinsically Safe: I, II, III/1-A/G, I/O/IIC Explosionproof: I/1/A-D Non incendiive: I/2/A-D, I/2/IIC Dust ignition proof: II, III/1/EFG Special protection: II/2/FG	TP48-X-Y-Z
Canada (FM)	C22.2 No. 157 C22.2 No. 213 C22.2 No. 142 C22.2 No. 94 C22.2 No. 30	3025374	Intrinsically Safe: I, II, III/1-A/G, I/O/IIC Explosionproof: I/1/A-D Nonincendiive: I/2/A-D, I/2/IIC Dust ignition proof: II, III/1/EFG Special protection: II/2/FG	TP48-X-Y-Z
Global	IEC 60079-0:2004 IEC 60079-11:2006 IEC 61241-0:2004 IEC 61241-1:2004	IECEx BAS 07.0045X	Ex ia IIC T4/T5/T6 Ex tD A20 IP6X T85°C/T100°C/ T135°C	TP48-X-Y-NDI

Key: X = 3 or 4 or blank, Y = N, I or G, Z = NDI

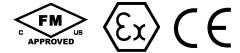

Technical Data

Nominal voltage Un	35V
Rated voltage (MCOV) Uc	58V
Nominal current In	-
Nominal discharge current (8/20µs) isn	3kA
Max discharge current (8/20µs) Imax	20kA
Lightning impulse current (10/350µs) Imp	2.5kA
Residual voltage @ isn Up	95V
	L-G 500V
Voltage protection level @ 1kV/µs Up	<76V
Bandwidth fg	1MHz
Capacitance C	100pF
Series resistance R	-
Operating Temperature Range	-40°C to +85°C
Category tested	A2, B2, C1, C2, C3, D1
Overstressed fault mode in=3kA	12kA
Impulse durability (8/20µs)	10kA
Degree of protection	IP66
AC durability	1A _{rms} , 5T
Service conditions	80kPa - 160kPa 5% - 95% RH

TP48 Series	
Nominal voltage Un	35V
Rated voltage (MCOV) Uc	58V
Nominal current In	-
Nominal discharge current (8/20µs) isn	3kA
Max discharge current (8/20µs) Imax	20kA
Lightning impulse current (10/350µs) Imp	2.5kA
Residual voltage @ isn Up	95V
	L-G 500V
Voltage protection level @ 1kV/µs Up	<76V
Bandwidth fg	1MHz
Capacitance C	100pF
Series resistance R	-
Operating Temperature Range	-40°C to +85°C
Category tested	A2, B2, C1, C2, C3, D1
Overstressed fault mode in=3kA	12kA
Impulse durability (8/20µs)	10kA
Degree of protection	IP66
AC durability	1A _{rms} , 5T
Service conditions	80kPa - 160kPa 5% - 95% RH

Ordering Data

Description	Part No.
Non-certified SPD - 1/2" NPT thread	TP48N
Non-certified SPD - 20mm ISO thread	TP48I
Non-certified SPD - G 1/2" (BSP 1/2 inch)	TP48G
Non-certified SPD - 1/2" NPT thread	TP483N
Non-certified SPD - 20mm ISO thread	TP483I
Non-certified SPD - G 1/2" BSP 1/2 inch	TP483G
Non-certified SPD - 1/2" NPT thread	TP484N
Non-certified SPD - 20mm ISO thread	TP484I
Non-certified SPD - G 1/2" BSP 1/2 inch	TP484G
Certified SPD - 1/2" NPT thread	TP48NNDI
Certified SPD - 20mm ISO thread	TP48INDI
Certified SPD - G 1/2" (BSP 1/2 inch)	TP48GNDI
Certified SPD - 1/2" NPT thread	TP483NNDI
Certified SPD - 20mm ISO thread	TP483INDI
Certified SPD - G 1/2" - BSP 1/2 inch	TP483GNDI
Certified SPD - 1/2" NPT thread	TP484NNDI
Certified SPD - 20mm ISO thread	TP484INDI
Certified SPD - G 1/2" - BSP 1/2 inch	TP484GNDI

Installation

The TP units are designed for mounting directly into an unused conduit entry on a process transmitter housing. Generally, two such entries are provided, one of which is used for the loop wiring. On the unused entry, the blanking plug or other closure device is removed and an appropriately threaded TP screwed into its place. The transmitter specification should provide information indicating the required thread type. TP units can be installed using thread adaptors if necessary, including certified adaptors in hazardous area applications.

For applications where two conduit entries are not provided or where both are used for electrical connections, TP units can be housed in conventional conduit hub or junction boxes, provided access to the loop terminals is possible. Figure 2 shows connection details for 3 & 4 wire process transmitter.

Figure 2

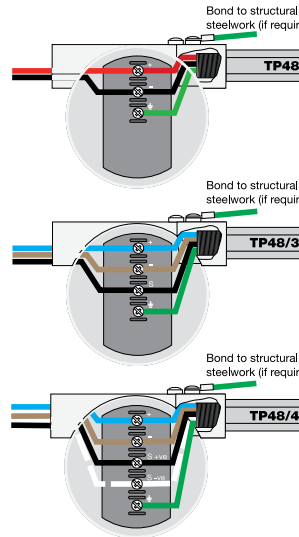

Glossary

3 + 1 circuit	Surge protection for TT-/TNS power networks with 3 varistors and an N-PE spark gap. There are no parasitic voltages in the event of defective varistors.
Ageing	Change in the original power data caused by interference pulse due to operations or unfavourable environmental conditions.
Arrester	Protective device that discharges the energy either symmetrically between the conductors or asymmetrically between the cables and the earth.
Asymmetric interference voltage	Voltage between the "electrical centre", and common ground (earth). Voltage between conductor and signal ground (earth).
Back-up fuse	Dependent on the connection cross-section and/or maximum longitudinal decoupling of the proposed fuse.
Binary signals	Switching signals with on and off states.
Burst	For a surge pulse that reoccurs during a specific time interval.
Cable lengths	With a spur line connecting the lightning arrester, the length of the phase-side and earth-side cables should be kept as short as possible and should never be longer than 0.5 metres / 20 inch. The earth-side connection should be as short as possible. Installation site: At the feed point of the facility, for Type I and II. In the immediate vicinity of the end device being protected for Type III.
Capacitive coupling	Coupling of the interference circuit and the useful circuit because of a potential difference with coupling capacitances.
Combination circuit	Protective circuit (e.g. from gas discharge tube, varistor and/or suppressor diode)
Combined pulse	The hybrid generator, when idle, creates a 1.2/50 μ s pulse and, when in short circuit, a 8/20 μ s pulse. The ratio of peak open-circuit voltage (U_{Oc}) to peak short-circuit current (I_{sc}) is 2 ohms.
Common-mode interference	The interference source is between a signal wire and a reference conductor (e.g. capacitive coupling, or increase in potential of spatially dispersed earths).
Continuous operating current I_c	Current per protective path for continuous voltage U_c .
Cut-off mechanism	Device which disconnects the arrester in case of a system malfunction and displays this.
Degree of protection for housing (IP code)	Degree of protection ensured by the housing against touch access to live parts and against the ingress of solid foreign objects or water. Testing in accordance with IEC 529 section 7.4.
Differential-mode interference	Interference source and useful source are in series (e.g. magnetic or galvanic coupling).
EMC	Electromagnetic compatibility.
External lightning protection	The external lightning protection consists primarily of an air-termination device, arresters and an earthing system. It is responsible for protecting the facility buildings from lightning strikes which could cause fire or mechanical destruction.
Follow-on current I_f	Current that flows through the surge protection device immediately following a discharge and is delivered from the power grid.
Follow-on current extinguishing capability I_{fi}	The VPU I, II and III series do not generate any power follow current between L-PEN (follow current) and thus simplify the installation. Therefore, the strength of the short circuit current, or power follow current, from the generator or transformer, does not have to be taken into account.



Fuse, back-up fuse	A back-up fuse is required if the upstream fuse F1 is greater than the maximum value specified by the manufacturer. Remember to select the largest nominal value in keeping with the ratio F1 to F2 (back-up fuse before SPD) = 1 : 1.6. Be sure to take the triggering characteristics into account if a circuit breaker is being used in the surge protection equipment instead of the fuse specified in the installation instructions.
Galvanic coupling	The interference circuit and the useful circuit have a common impedance.
Gas discharge tube	Voltage-dependent, encapsulated switch with high current-carrying capacity.
HAK	House junction box.
I&C	Measurement and control systems.
IMAX	Maximum current that can be switched by an arrester.
Inductive coupling	Coupling from two or more current-carrying conductor loops.
Insertion loss (attenuation)	Attenuation in decibels that is added by inserting a four-pole.
INSTA	Installation housing in accordance with DIN 43880, suitable for installation in distribution boards.
Insulation co-ordination or rated impulse withstand voltage	Standing surge current strength of the insulation in parts of the facility, according to DIN VDE 0110 T.1.
Internal lightning protection	Internal lightning protection refers to protecting electrical equipment from power surges.
Intrinsically safe circuit	Intrinsically safe circuits are especially vulnerable because even a small amount of energy is sufficient to nullify their intrinsic safety. During the installation of intrinsically safe circuits (including cables and wires), be sure that you do not exceed the maximum allowable inductance, capacitance, or the L/R ratio and the surface temperature.
I_L	Maximum nominal current via the internal cross-connection of an arrester with two connections for one phase.
$I_{peak} = I_{imp}$	Current peak value of a test pulse.
I_{sn}	Peak value of the nominal discharge current.
IT power network	Power system with three phase conductors, constructed with insulation to the earth potential. The building's PE is not connected to the power grid.
Leakage current	Current that flows to PE at nominal voltage.
LEMP	Lightning electromagnetic pulse = electromagnetic interference pulse.
Lightning protection equipotential bonding	Equipotential bonding of separated metal parts with the LPS using a direct connection or connection via surge protection devices in order to reduce the lightning current caused by the potential difference.
Lightning pulse current I_{imp}	Defined by the peak value I_{peak} and the charge Q, when tested in accordance with Type I with 10/350 μ s pulse.
Limiting frequency	Specifies the max. frequency at which a transfer will function. At higher frequencies, the protective circuit cushions so strongly that no transfer is possible.
Longitudinal voltage	Interference voltage between the active conductor and the earth.

LPL	<p>Lightning protection level LPL I = 200 kA LPL II = 150 kA LPL III = 100 kA Maximum lightning current that can enter as a direct strike in the external lightning protection. Various applications and buildings are categorised according to these lightning protection levels. 10/350 µs: test current for lightning arrester (Type I products), for simulating or reproducing a lightning bolt. 8/20 µs: test current for lightning arrester (Type II products), for simulating or reproducing a surge voltage.</p>
LPS	<p>Lightning protection system – a complete system that is used to reduce the physical damage to a building or facility that could be caused by direct lightning strikes.</p>
LPZ	<p>Lightning protection zone = lightning protection zone The lightning protection zones are divided into: external lightning protection LPZ 0 / OA / OB and internal lightning protection LPZ 1, 2, 3.</p>
Max. continuous voltage U_c	<p>The highest RMS value of the AC voltage or the highest value of the DC voltage that is allowed continually on the protective path of the surge protection device. Continual voltage = rated voltage.</p>
Maximum discharge surge current I_{max}	<p>Peak value of the current 8/20 µs during duty test for Type II (type 40 kA).</p>
Measured limiting voltage	<p>Max. voltage level while loading with pulses of a specific form and amplitude during the test.</p>
MOV	<p>See varistor.</p>
Nominal discharge surge current	<p>At peak value of the surge current 8/20 µs, during test for Type II (type 20 kA)</p>
PAS main earth rail	<p>Metal rail which is connected with the foundation, and which can be used to connect metal installations, external conductive parts, power supply cables, telecommunications cables, water pipes and gas pipes to the LPS.</p>
PE	<p>Protective system and earth system to which energy is discharged.</p>
Protection level, U_p	<p>Specifies the residual voltage that can still be measured at the terminals during a surge voltage pulse (preferred value is greater than the largest measured limiting voltage). Important parameter that characterises the performance of the SPD.</p>
Protective path	<p>Component circuitry in a SPD: conductor to conductor, conductor to earth, conductor to neutral, neutral to earth are designated as protective paths.</p>
Pulse current 10/350 µs	<p>Pulse voltage with a front time of 10 µs and a half-value time of 350 µs.</p>
Pulse current 8/20 µs	<p>Pulse voltage with a front time of 8 µs and a half-value time of 20 µs.</p>
Pulse voltage 1.2/50 µs	<p>Pulse voltage with a front time of 1.2 µs and a half-value time of 50 µs .</p>
Radiation coupling	<p>Electromagnetic field coupled to one or more conductive loops.</p>
Rated voltage UC	<p>The maximum RMS value of the AC voltage which may continuously be applied to an arrester.</p>
RCD circuit breaker	<p>If a fault current exceeds a certain threshold, then the RCD switches off within 0.2 seconds.</p>
Recommended fuse	<p>The nominal value of the fuse recommended by the manufacturer and specified by the technical data sheet.</p>



Weidmuller – Partner in Industrial Connectivity

As experienced experts we support our customers and partners around the world with products, solutions and services in the industrial environment of power, signal and data. We are at home in their industries and markets and know the technological challenges of tomorrow. We are therefore continuously developing innovative, sustainable and useful solutions for their individual needs. Together we set standards in Industrial Connectivity.

Weidmuller, Canada

10 Spy Court
Markham, Ontario L3R 5H6
Telephone: (800) 268-4080
Facsimile: (877) 300-5635
Email: info1@weidmuller.ca
Website: www.weidmuller.ca

07/16 • 750 • LIT1325

Weidmuller, Mexico

Bldv. Hermanos Serdán 698,
Col. San Rafael Oriente
Puebla, Puebla, Mexico
C.P. 72029
Telephone: 01 222 2686267
Facsimile: 01 222 2686219
Email: clientes@weidmuller.com.mx
Website: www.weidmuller.com.mx

Weidmuller, United States

821 Southlake Blvd.
Richmond, Virginia 23236
Telephone: (800) 849-9343
Facsimile: (804) 379-2593
Email: info@weidmuller.com
Website: www.weidmuller.com

Order number: XXXXXXXXXXXX/00/2016/XXXX