

# PrintJet CONNECT

PrintJet CONNECT 2715590000



Marking system, user manual



# Contents

<b>1</b>	<b>About this documentation</b>	<b>4</b>	<b>5</b>	<b>Operation</b>	<b>31</b>
1.1	Overall documentation	4	5.1	Information about operation	31
1.2	Used symbols and signal words	4	5.2	Inserting MultiCards / MetalliCards	32
1.3	Warranty and liability	5	5.3	Software settings	34
1.4	Copyright	5	5.4	Automatic adjustment	34
1.5	Guarantee terms and conditions	5	5.5	Printing MultiCards/MetalliCards	34
<b>2</b>	<b>General safety information</b>	<b>6</b>	5.6	Settings on the touch panel	35
2.1	General operating information	6	<b>6</b>	<b>Cleaning and maintenance</b>	<b>40</b>
2.2	Recycling in accordance with WEEE	7	6.1	Safety information	40
2.3	Symbols and information used on the device	8	6.2	Software-controlled maintenance	40
2.4	Intended use	8	6.3	Manual print head cleaning	42
2.5	Residual risks when using the device	9	6.4	Replacing ink cartridges and fluid cartridges	43
2.6	Safety devices and guards	10	6.5	Calibration of the print heads	45
2.7	Personnel requirements	10	6.6	Replacing the ink collector	49
<b>3</b>	<b>Printer description</b>	<b>11</b>	6.7	Cleaning the printer enclosure / touch panel	51
3.1	Printer	12	6.8	Updating the printer software	51
3.2	Touch panel	15	<b>7</b>	<b>Troubleshooting</b>	<b>53</b>
3.3	MultiCards and MetalliCards	20	7.1	General information	53
<b>4</b>	<b>Setup</b>	<b>22</b>	7.2	Trouble list	54
4.1	Unpacking	22	<b>8</b>	<b>Decommissioning the printer</b>	<b>56</b>
4.2	Scope of supply	22	8.1	Downtime mode	56
4.3	Installing the printer	22	8.2	Packing and transporting the printer	56
4.4	Extracting the output magazine	24	8.3	Disposing of the printer	56
4.5	Aligning the touch panel	24	<b>9</b>	<b>Annex</b>	<b>57</b>
4.6	Connecting the printer	25	9.1	Technical data	57
4.7	Turning on the printer / Switching the printer to standby mode	26	9.2	Ordering data	58
4.8	Inserting ink cartridges	26	9.3	Declaration of Conformity	58
4.9	Language selection on the touch panel	28			
4.10	Installing the M-Print® PRO marking software	28			
4.11	Setting up and adjusting a MultiCard for the printer	30			
4.12	Running a print test	30			

## Manufacturer

Weidmüller Interface GmbH & Co. KG  
Klingenbergstraße 26  
32758 Detmold, Germany  
T +49 5231 14-0  
F +49 5231 14-292083  
www.weidmueller.com

Document no. 2769150000  
Revision 02/April 2026

# 1 About this documentation

This user manual provides all the information you need for trouble-free operation of the PrintJet **CONNECT** printer (hereafter called printer or device).

This user manual must be read, understood, and followed by members of staff before commencing work, maintenance tasks, cleaning, and troubleshooting at the printer. This applies, in particular, to any safety information.

After reading the user manual, you will be able to

- operate the printer safely,
- clean the printer correctly,
- take appropriate action in the event of a fault.

In addition to this user manual, it is necessary to comply with the general laws and other regulations concerning accident prevention and environmental protection in the country of use. This user manual is an integral part of the printer. It must be kept with the printer throughout its service life.

## 1.1 Overall documentation

The overall documentation includes the following documents:

- User manual PrintJet **CONNECT**
- Quick guide PrintJet **CONNECT**
- User manual M-Print® PRO

The documents and product downloads (e.g., M-Print® PRO software) can be downloaded from the online shop (<https://eshop.weidmueller.com>).

The article page can be opened by entering the article name or article number in the search bar.

After clicking the "Product Downloads" button, the documents and product downloads associated with the article are displayed.

Alternatively, you can scan the QR code on the rating plate of the PrintJet **CONNECT** or on the enclosed quick guide. After entering the article number, all available downloads are displayed.

### Article numbers

- PrintJet **CONNECT**: 2715590000
- M-Print® PRO: 1905490000

## 1.2 Used symbols and signal words

The warnings in this user manual vary according to the severity of the danger.



	<b>DANGER</b>
	<p><b>Danger of death!</b></p> <p>Information with the signal word "Danger" warns of situations that result in fatal or serious injuries if the instructions given are not observed.</p>







	<b>WARNING</b>
	<p><b>Possible danger of death!</b></p> <p>Information with the signal word "Warning" warns of situations that can result in fatal or serious injuries if the instructions given are not observed.</p>

	<b>CAUTION</b>
	<p><b>Danger of injury!</b></p> <p>Information with the signal word "Caution" warns of situations that can result in injuries if the instructions given are not observed.</p>

<b>ATTENTION</b>	
<b>Damage to property!</b>	
Information with the signal word "Attention" warns of dangers which may result in damage to property.	

The situation-related warnings may contain the following warning symbols:

Symbol	Meaning
	Warning of high voltage
	Warning of hand injury (crushing)
	Warning of burns from hot surfaces

Symbol	Meaning
	Warning of automatic printer start-up
	Warning of hand injuries due to sharp objects
	Warning of electromagnetic interference
	Work may only be carried out by electrical specialists.
	Always wear personal protective equipment when carrying out work.
	Information about the documentation

In the remaining text, further formatting is used, which has the following meaning:

 Texts next to this arrow represent instructions which are not safety relevant but provide important information for correct and effective work.

- ▶ Texts following this mark represent instructions for action.
- Texts following this mark represent an item in a list.

### 1.3 Warranty and liability

The obligations specified in the supply contract, the general and delivery terms and conditions of Weidmüller Interface GmbH & Co. KG, and the legal regulations in force at the time the contract was signed apply.

All the information and instructions in this user manual have been compiled in line with applicable standards and regulations, state-of-the-art technology, and our extensive knowledge and experience.

Warranty and liability claims for personal injury and material damage are excluded if they are attributable to one or more of the following causes:

- Unintended or inappropriate use of the printer (see chapter 2.4 on page 8)
- Inappropriate installation, commissioning, operation, maintenance, and cleaning of the printer
- Operation of the printer with defective or incorrectly fitted printer enclosure
- Non-compliance with the user manual
- Deployment of non-instructed personnel
- Structural alterations to the printer (modifications or other alterations to the printer are prohibited. Non-compliance will result in the printer's EC Declaration of Conformity no longer being valid)
- Technical modifications
- Opening the printer enclosure
- Use of out-of-date ink cartridges
- Use of unapproved spare parts or spare parts that do not satisfy technical requirements
- Disasters, effects of extraneous elements, and force majeure

We reserve the right to make technical alterations in the course of further development and improvement of features.

### 1.4 Copyright

This user manual is protected by copyright and intended for internal use only.

Without the written consent of Weidmüller Interface GmbH & Co. KG, any use outside the limits of copyright law is prohibited. This applies in particular to copies and translations.

Contravention results in liability for damages. Further claims remain reserved.

### 1.5 Guarantee terms and conditions

The guarantee terms and conditions are contained in the general terms and conditions of Weidmüller Interface GmbH & Co. KG.

## 2 General safety information

<b>WARNING</b>	
	<p><b>Failure to observe the safety information below may result in serious injuries!</b></p> <p>Risk to persons due to electrical and chemical hazards</p> <ul style="list-style-type: none"><li>▶ Read the safety and hazard information in this chapter thoroughly before putting the printer into operation.</li><li>▶ In addition to the information in this user manual, observe the applicable national work, operating and safety regulations.</li><li>▶ Observe the applicable internal company regulations.</li></ul>

In the following cases, you must disconnect the printer from all sources of power and contact a qualified service technician:

- The power cable or plug are worn or damaged.
- Liquid has entered the printer.
- The printer has fallen down or the enclosure has been damaged.
- The performance of the printer is not up to the required standard, e.g. poor print quality or insufficient resistance to smearing and scratching.

<b>CAUTION</b>	
	<p><b>Danger of injury when the printer is open!</b></p> <p>Tampering with the printer when it is open may result in cuts and crush injuries.</p> <ul style="list-style-type: none"><li>▶ Never remove the printer enclosure.</li><li>▶ Have components inside the device replaced by a Weidmüller service technician.</li></ul>

<b>ATTENTION</b>	
<p><b>Damage to the device!</b></p> <p>The printer enclosure should not be removed. Opening the printer will result in the loss of any warranty rights.</p>	

- Make sure that all persons who work on the device have fully read and understood the user manual.
- Only use the printer for its intended purpose (see chapter 2.4 on page 8).
- Keep all safety information and warnings on the printer clean and legible; renew them, if necessary.

- Only instructed personnel should work on the device.
- Always keep the user manual with the product for future reference. It must be ensured that everyone involved with the device is able to view the user manual at any time.

### 2.1 General operating information

- When selecting the installation site for the printer, ensure the ambient conditions are suitable (see chapter 9.1 on page 57).
- Make sure that openings in the printer enclosure are not blocked or covered.
- Do not turn off the printer!
- Do not turn off the printer! The printer automatically switches to standby mode. The operating parameters are only retained while the printer is turned on. These parameters ensure, for example, that the print head is cleaned optimally.
- Keep the ink tank lid closed during operation.



Only use products that have been produced or approved by Weidmüller (M-Print® PRO marking software, MultiCards/MetalliCards, and ink cartridges).

Poor print quality, printer faults and damage caused by the use of unapproved and unsuitable accessories and consumables are excluded from the warranty.

### 2.1.1 Handling ink and fluid cartridges

- Keep ink and fluid cartridges out of reach of children.
- The ink and fluid are not suitable for consumption. Do not allow ink to come into contact with the mucous membranes. If you accidentally swallow any ink, rinse out your mouth and drink plenty of water. Do not induce vomiting.
- Always handle ink and fluid cartridges with care, otherwise ink or fluid could spill and cause soiling.
- Always handle used ink and fluid cartridges with care as a small amount of ink or fluid could remain in the supply outlet. If you get ink or fluid on your skin, wash thoroughly with soap and water.
- Never touch the ink or fluid cartridge supply outlet or the area of the supply outlet.
- Do not shake ink or fluid cartridges, as this may cause ink of fluid to leak.
- Do not disassemble or try to refill ink or fluid cartridges.
- Store unopened ink or fluid cartridges in a cool and dry place, preferably in a refrigerator at approx. 4°C. Allow cooled ink or fluid cartridges to warm to room temperature for at least three hours before use.
- Only remove ink cartridges from the printer when they are empty or out of date.
- Do not use out-of-date ink cartridges.
- When the use-by date of the ink approaches (printed on the packaging), a message is displayed on the touch panel. Use all the ink in the ink cartridge by the date stated on the label to achieve the best print results.

#### ATTENTION

##### Damage to the device due to old ink!

Using out-of-date ink may cause damage to the printer.

### 2.2 Recycling in accordance with WEEE

Products marked with this symbol are subject to Directive: 2012/19/EU: Take-back and recycling of electrical and electronic equipment



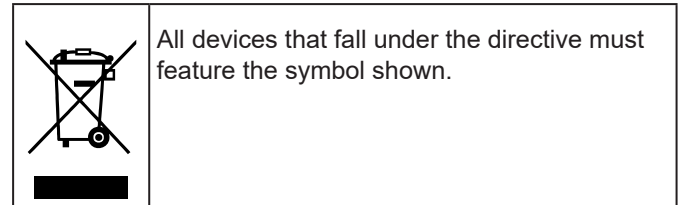

The products contain substances that can be dangerous to the environment and health. Therefore, do not dispose of the products in unsorted municipal waste.

You can return the products to Weidmüller at the end of their life cycle; we will then ensure that they are disposed of properly. Send the products properly packed to your sales agent.

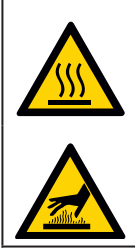

### 2.3 Symbols and information used on the device

The following information and symbols are attached to the printer:

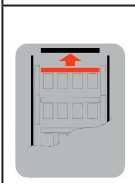
	<p><b>Warning of hot surface</b> These symbols warn of a burn hazard due to hot surfaces.</p>
	<p><b>Warning of crush hazard</b> This symbol warns of a crush hazard, for instance to your hands.</p>
	<p><b>Warning of automatic start-up</b> This symbol warns of automatic printer start-up.</p>
	<p><b>Warning of sharp objects</b> This symbol warns of potential hand injuries due to sharp objects.</p>
	<p><b>Insertion instructions</b> This symbol displays the correct insertion direction of the MultiCards.</p>

Warning label on the device	
<b>Achtung: Gerät nicht öffnen !</b>	<b>Attention: Do not open the printer !</b>
<p>Verletzungsgefahr ! Es gibt keine zu wartenden Teile im Inneren des Gerätes. Durch Öffnen verlieren Sie alle Garantieansprüche.</p>	<p>Risk of injury ! There are no serviceable parts inside the housing. Opening will cause loss of any warranty rights.</p>
<ul style="list-style-type: none"> <li>• Apparatets stikprop skal tilsluttes en stikkontakt med jord, som giver forbindelse til stikproppens jord.</li> <li>• Apparaten skall anslutas till jordat uttag.</li> <li>• Apparatet må tilkoples jordet stikkontakt.</li> <li>• Laite on liitettävä suojakoskeftimilla varustettuun pistorasiaan.</li> </ul>	

 Keep all safety information and warnings on the device clean and legible; renew them, if necessary.

### 2.4 Intended use

In conjunction with the M-Print® PRO marking software, the printer is designed for marking MultiCards and MetalliCards in commercial and industrial applications. Any other use is prohibited. Using the printer in unapproved applications will immediately lead to the expiration of all guarantee and warranty claims on the part of the operator against the manufacturer.

Using the printer for purposes other than those specified or failure to observe the operating instructions and warnings can lead to serious malfunctioning, personal injury or damage to property.

Only use the M-Print® PRO marking software, MultiCards/MetalliCards, and inks which have been approved for this marking system by Weidmüller.

Weidmüller can make no guarantee for the print quality and resistance when a different marking software and other MultiCards/MetalliCards and ink are used.

Claims of any kind for personal injury or material damage arising from unintended use are ruled out. The plant operator alone is liable for any injury or damage attributable to unintended use.

Intended use also includes:

- Heeding all information in the user manual
- Complying with the operating and maintenance conditions.

#### Structural modifications to the device

Construction and acceptance are based on the German Product Safety Act (ProdSG). Never modify the printer. Non-compliance will invalidate the printer's EC Declaration of Conformity. Such a breach absolves the manufacturer of the printer from warranty. Have any defective components of the printer replaced immediately by a Weidmüller service technician.

## 2.5 Residual risks when using the device

The device has a state-of-the-art design and complies with recognized safety rules and regulations. However, impairments can still arise when using the device.

Only use the device for its intended purpose.

When using the device, observe the warnings on the device and the safety information in this user manual.

### 2.5.1 Hazards due to electricity

	DANGER
	<p><b>Warning of electrical hazard!</b></p> <p>Touching live parts is a direct risk to life. Damage to the insulation or individual components may result in fatal injury.</p> <ul style="list-style-type: none"> <li>▶ Work on the printer's electrical components may only be carried out by electrical specialists.</li> <li>▶ Only connect the device to a properly grounded and fused socket.</li> <li>▶ Do not connect the printer to either a switch-operated or a timer-controlled socket.</li> <li>▶ Never use damaged power cables.</li> <li>▶ Have the printer's electrical components regularly inspected for defects, such as loose connections or damage to the insulation.</li> <li>▶ If damage is detected, immediately switch off the power supply to the printer and have the damage repaired.</li> <li>▶ Have all connecting cables and plugs inspected by an electrical specialist at least every 6 months!</li> <li>▶ Never bypass fuses and never take them out of operation.</li> <li>▶ When replacing fuses, pay attention to the correct amperage.</li> <li>▶ When connecting the printer using an extension cable, make sure that the rated current value does not exceed the ampere rating of the extension cable.</li> <li>▶ Keep moisture away from live parts as it can cause short circuits. Pay particular attention to this when cleaning the printer.</li> <li>▶ Modifications to the electrical equipment carried out after testing must comply with DIN EN 60204-1.</li> </ul>

### 2.5.2 Hazards due to hot surfaces

	CAUTION
	<p><b>Burn hazard due to hot surfaces!</b></p> <p>Contact with hot components and cards may cause burns.</p> <ul style="list-style-type: none"> <li>▶ Make sure all components have cooled down to the ambient temperature prior to carrying out any service or maintenance work.</li> </ul>

### 2.5.3 Hazards due to incorrect spare parts

ATTENTION
<b>Damage due to incorrect or faulty spare parts!</b>
Incorrect or faulty spare parts may cause damage, malfunctions or total failure. Use original spare parts only.

Obtain the spare parts from Weidmüller Interface GmbH & Co. KG. The necessary details about spare parts are given in chapter 9.2 on page 58.

## 2.6 Safety devices and guards

The printer is equipped with the following safety devices:

- Ink tank lid
- Service flap (ink collector)
- Mains plug



The printer may not be operated without the printer enclosure. The printer enclosure should not be removed.

Only operate the printer with the ink tank lid closed.

## 2.7 Personnel requirements

Only instructed personnel should operate the printer and perform maintenance tasks. Instruction also means that the user manual has been read fully.



Repairs may only be carried out after consultation with Weidmüller Service and only by an electrical specialist.

### 2.7.1 Qualifications required by personnel

The responsibilities of personnel for commissioning, operation, maintenance, and cleaning must be clearly defined.

Personnel require the following qualifications for the various activities:

Instructed skilled personnel
Instructed skilled personnel are able to do their work and recognize/avoid potential hazards on their own as a result of their training, knowledge, and experience, as well as their familiarity with the relevant regulations.
Electrical specialists
Electrical specialists are able to work independently on electrical devices and recognize/avoid potential hazards as a result of their training, knowledge, and experience, as well as their familiarity with the relevant standards and regulations. Electrical specialists have been trained for their specific task and know the relevant standards and regulations.

### 3 Printer description

Combined with the M-Print® PRO marking software, the ink-jet printer **PrintJet CONNECT** is a marking system for MultiCards and MetalliCards.

Individual equipment can be marked with the marking system. The printer labels markers in MultiCard format for switchgear, automatic machines, terminal blocks, cables, lines, and valves. The **PrintJet CONNECT** allows you to print very small fonts. Even the smallest characters are easy to read, permitting you to increase the markers' information density.

The MultiCards can be fed into the magazine individually or inserted as a stack of up to 50 MultiCards.

MetalliCards should only be inserted individually. Stack processing is not intended for MetalliCards. The MetalliCard is inserted into an inlay for processing.

The MultiCard fed into the printing unit is printed with a thermally-hardened ink and then transferred to a curing unit.

In the curing unit, the ink is then hardened with a special heat radiator. The duration of this process varies for MultiCards and MetalliCards.

Finally, the MultiCard is fed into the output magazine and the MetalliCard onto the output rail.

The stacked MultiCards and the MetalliCard can be removed.

The MultiCard/MetalliCard can be used immediately.

Please note that the MultiCards and MetalliCards become hot due to the curing process. If necessary, let them cool down before removing them from the output magazine or the output rail.

## 3.1 Printer

### 3.1.1 Overviews

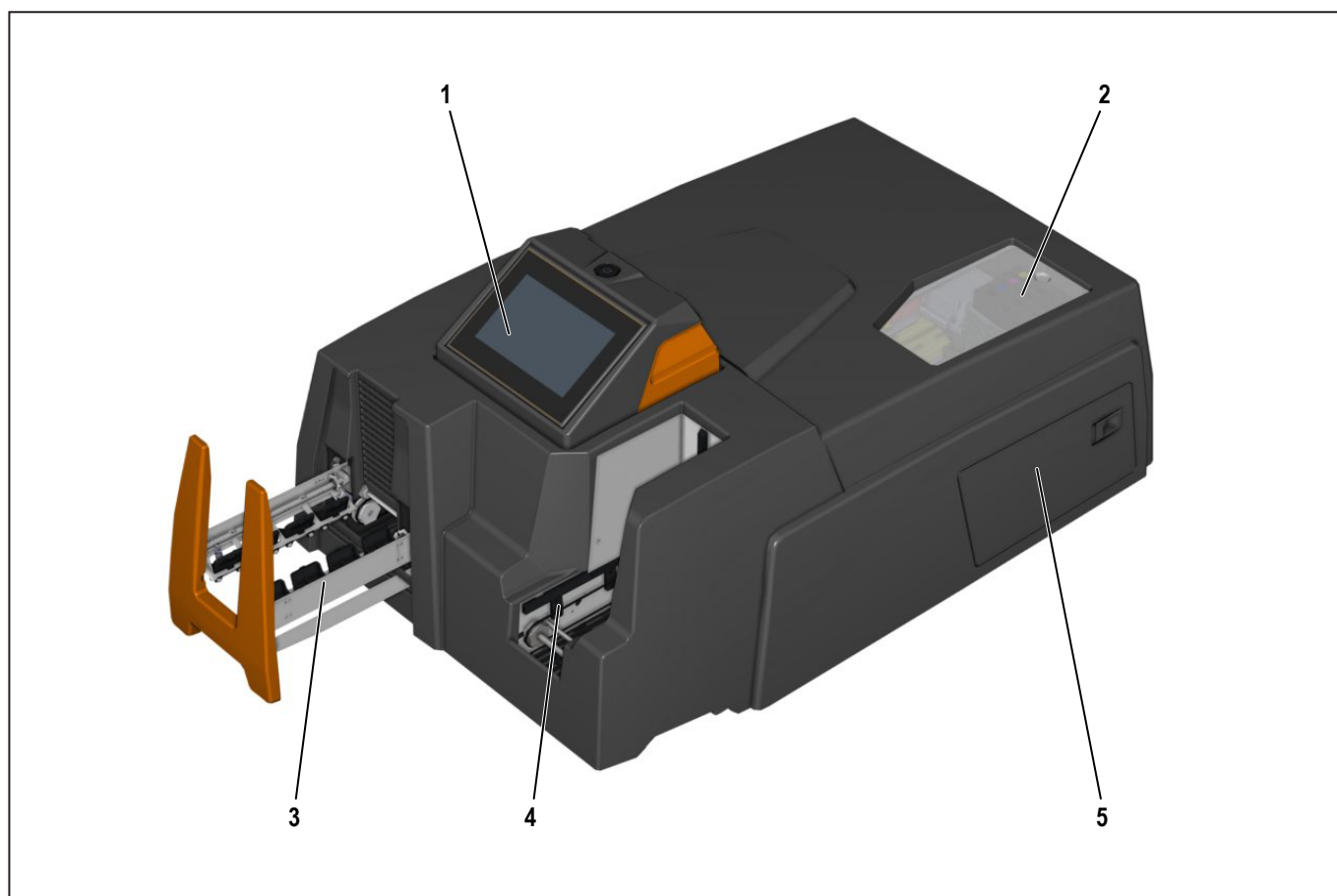

Figure 3.1 Printer view - front

- 1 Touch panel
- 2 Ink tank lid
- 3 Output magazine
- 4 Input magazine
- 5 Service flap (maintenance through user)

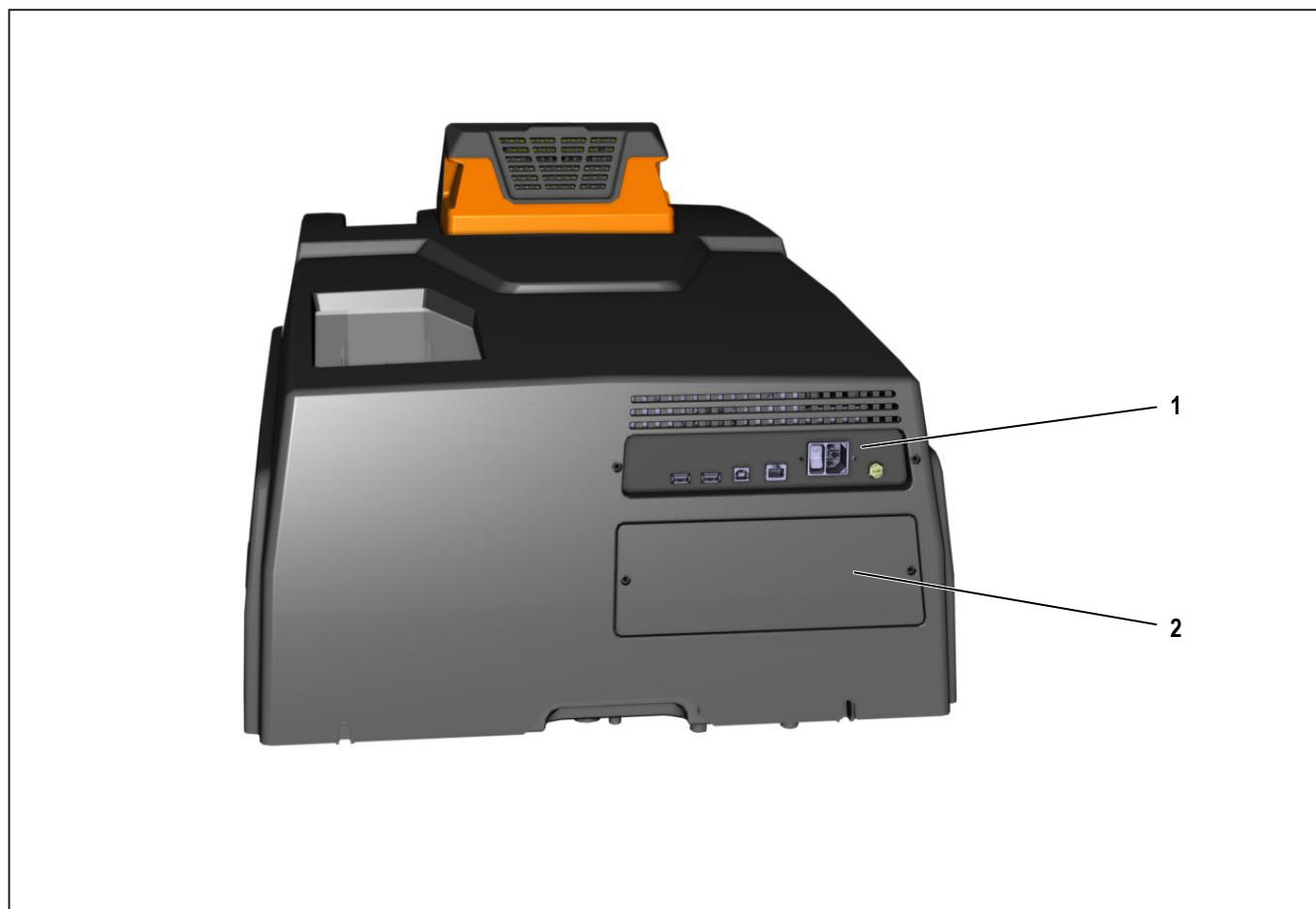

Figure 3.2 Printer view - rear

- 1 Connectors
- 2 Service cover (maintenance through Service staff)

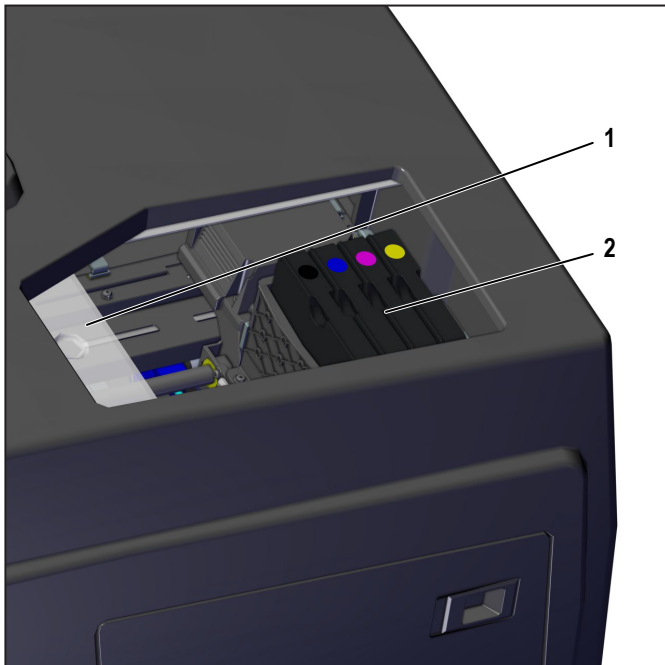

Figure 3.3 Ink tank lid open

- 1 Ink tank lid (open)
- 2 Ink cartridges

### 3.1.2 Connections

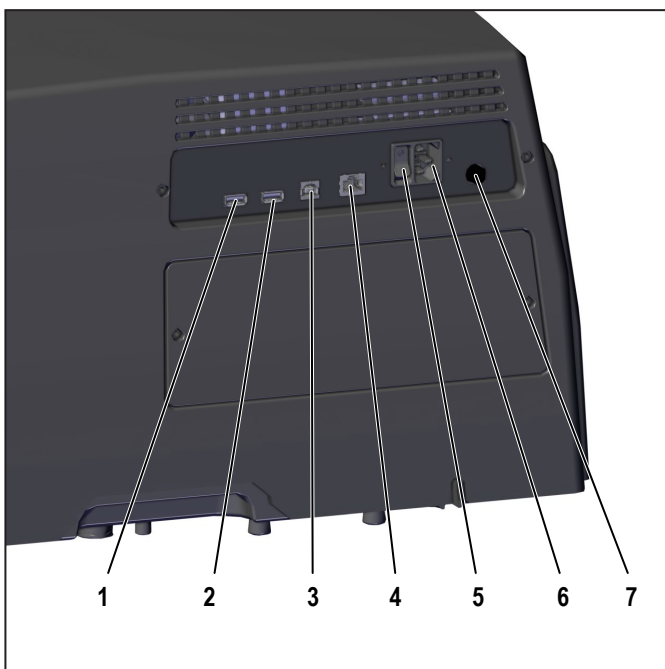

Figure 3.4 Connections

- 1 USB-A connector Wifi adapter/M-Print® PRO print jobs
- 2 USB-A connector Wifi adapter/M-Print® PRO print jobs
- 3 USB-B connector printer/PC
- 4 Ethernet port (LAN connection)
- 5 Main switch
- 6 Connection for mains plug (115/230 V)
- 7 Fuse (type: 10 AHT)

### 3.1.3 Rating plate

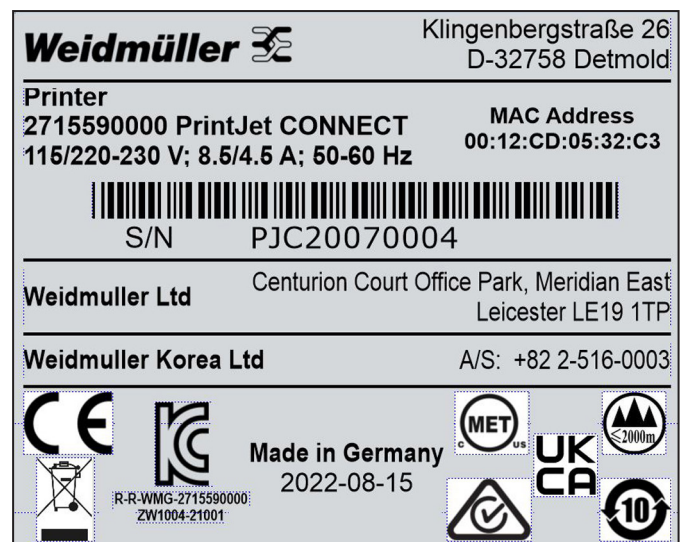







Figure 3.5 Rating plate

The rating plate contains information about the mains voltage, article number, serial number, and MAC address (address of the network card).





## 3.2 Touch panel





Figure 3.6 Start screen (main menu "System status")

Symbol	Main menu	Description
		Expands the symbol view with the names of the main menus.
	System status	Displays the current printer status: Readiness, fill level of the ink cartridges and the ink collector
	Jobs	Shows the available submenus: Current jobs, Print job history, Demo print jobs, USB stick print jobs
	Maintenance	Shows the available submenus: Print head cleaning, Nozzle check, Longer downtime
	Settings	Shows the available submenus: Interfaces, Language, Advanced settings, User groups, Support connection
	Information	Shows the submenu "System information".

### 3.2.1 Main menu "Jobs"

Symbol	Submenu	Description
	Current jobs	The current print jobs are displayed in this submenu along with the following information: <b>Number</b> Sequence number of the current print jobs <b>Marker type</b> Card type <b>Quantity</b> Quantity of cards <b>Status</b> Processing status <b>In process</b> The print job is being executed. <b>Wait</b> The print job will be executed as soon as the current print job has been completed.
	Print job history	This submenu displays the completed print jobs with information about the card type used.
	Demo print jobs	This submenu displays examples that can be executed as a print job.
	USB stick print jobs	This submenu displays print jobs that are stored on a USB stick and can be executed.





### 3.2.2 Main menu "Maintenance"

Symbol	Submenu	Description
	Print head cleaning	In this submenu, print head cleaning can be configured and executed.
	Nozzle check	In this submenu, a nozzle check can be carried out to check correct functionality of the nozzles.
	Longer downtime	In this submenu, the printer can be set to an operating mode for longer downtimes. All ink-carrying components are filled with fluid after replacing the ink cartridges with fluid cartridges. This ensures that the ink-carrying components are not clogged with dried ink when the printer is turned off.



### Main menu "Information"

Symbol	Submenu	Description
	System information	This submenu displays information in the following categories: <b>Ink</b> Fill level and shelf life of the ink cartridges, fill level of the ink collector <b>Printer</b> Individual characteristic data of the printer <b>Version number</b> Version of the current firmware <b>Environment</b> Current ambient conditions (temperature, humidity, voltage supply)















### 3.2.3 Main menu "Settings"











Symbol	Submenu	Description
	Interfaces	In this submenu, communication between the printer and the network is configured.
	Language	In this submenu, the language of the user interface can be set.
	Advanced settings	In this submenu, security-relevant settings for communication and print jobs are made. Manual calibration of the print heads can be performed.
	User groups	In this sub-menu, the access privileges to control the printer are defined. Three user levels can be selected.  <b>Administrator</b> Access to all the settings in all the main menus and the submenus.  <b>Superuser</b> Access to all the settings in the following main menus: System status, Jobs, Maintenance, Information  Access to all the settings in the following submenus: Language, User groups, Support connection  <b>User</b> Access to all the settings in the following submenus: Language, User groups (user switch), Support connection
	Support connection	Symbols and entries of the main menus and submenus for which there are no access privileges as superuser or user are hidden accordingly.  In this submenu, functions and parameters of the printer can be accessed via the remote maintenance function of Weidmüller Service.

### 3.2.4 Submenu "Interfaces"

Symbol	Submenu	Description
	Ethernet connection	In this submenu, communication between the printer and the network when the printer is communicating via LAN cable can be configured.
	WiFi connection	In this submenu, communication between the printer and the network when the printer is communicating via WLAN (WLAN USB stick) can be configured.
	USB connection	In this submenu, communication between the printer and the PC when print jobs are sent to the printer via USB connection can be configured. The USB connection is configured in M-Print® PRO (see "M-Print® PRO user manual").

### 3.2.5 Function elements of the user interface

Symbol	Name	Description
	Confirm	Confirms the selected user level. Opens the window with information about the fill level of the ink cartridges and the ink collector.
	Edit	Changes the password via the virtual keyboard.
	Discard	Discards any changes made.
	Show online help	Shows the online help for the corresponding function.
	Close online help	Closes the current page of the online help.
	Start animation	Starts an animation for service work.
	Print	Prints the displayed print job again.
	Scroll backward	Scrolls backward in the list.
	Scroll forward	Scrolls forward in the list.
	Move up	Moves the selected print job up.
	Move down	Moves the selected print job down.
	Delete individual	Deletes the marked print jobs.
	Delete all	Deletes all print jobs.
	Reload	Reloads the connected USB stick.
	Clean	Executes the configured print head cleaning.

Symbol	Name	Description
	Save	Saves the setting.
	Connect / Disconnect	Connects or disconnects the printer and the network.
	Activate remote maintenance	Activates the remote maintenance function.
	Interrupt connection	Interrupts the connection after support.
	Show print jobs	Shows the current print jobs.
	Show trouble list	Shows the list with fault or service messages if more than one message has been issued.
	Checkbox activated	Function is selected.
	Checkbox deactivated	Function is not selected.
		Selects the "Black" and "Cyan" nozzles for print head cleaning.
		Selects the "Magenta" and "Yellow" nozzles for print head cleaning.

### 3.3 MultiCards and MetalliCards

MultiCards made from plastic and MetalliCards made from aluminum or stainless steel can be printed with the printer. The marking system, consisting of the PrintJet **CONNECT** printer and the M-Print® PRO marking software, has been designed by Weidmüller for MultiCards and MetalliCards.

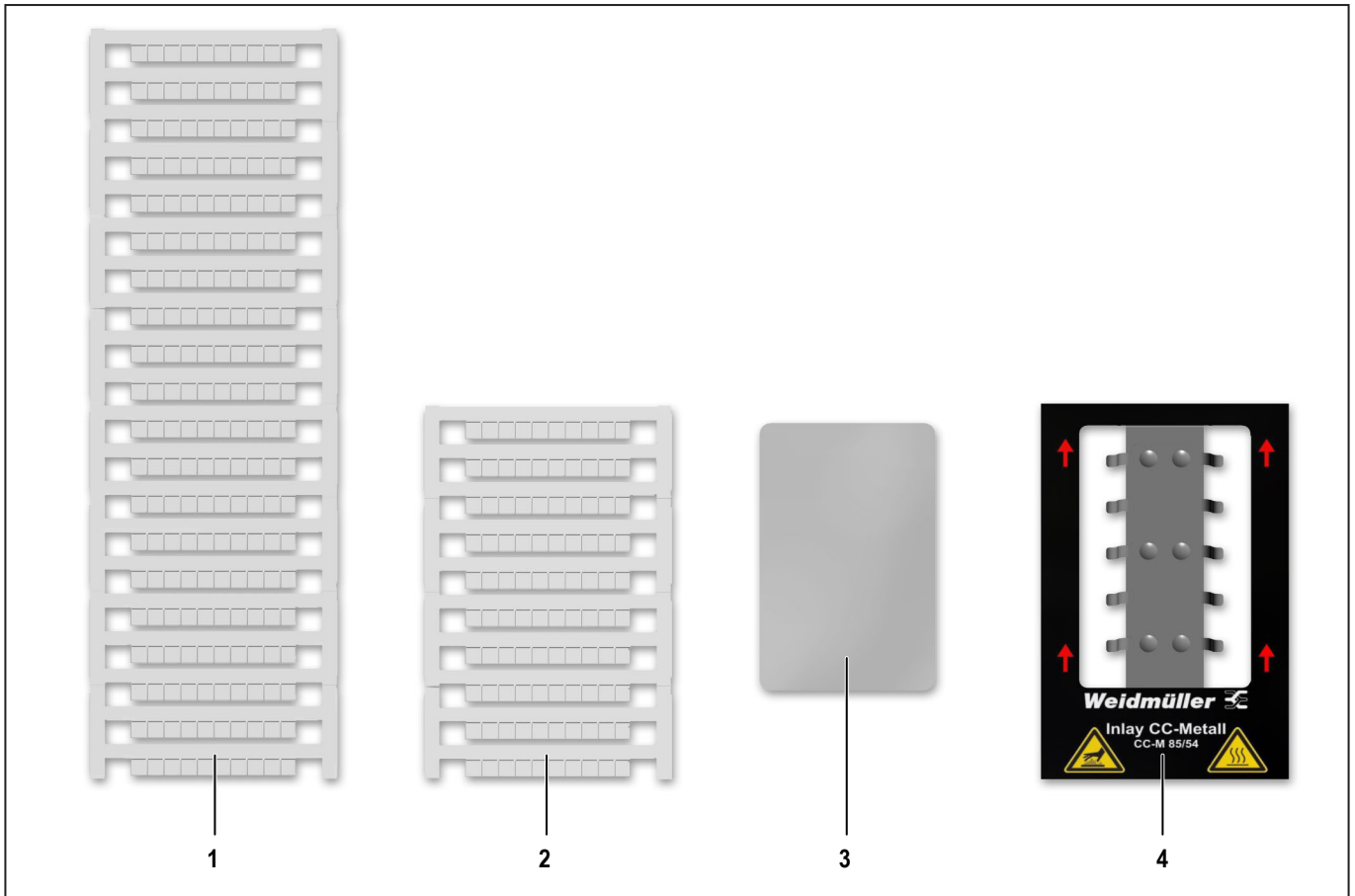

Figure 3.7 MultiCards/MetalliCard (examples)

- 1 MultiCard
- 2 Half MultiCard
- 3 MetalliCard
- 4 Inlay for MetalliCards

The MultiCards can be inserted individually or in stacks. MetalliCards should only be inserted individually. MultiCards can be halved. To receive a half MultiCard, bend the complete MultiCard in the middle and break in half. Complete and half MultiCards should not be mixed in a stack. It is, however, possible to process different MultiCard types in a stack, e.g. DEK 5/5 and SM 27/27.

### 3.3.1 Description of the MultiCard

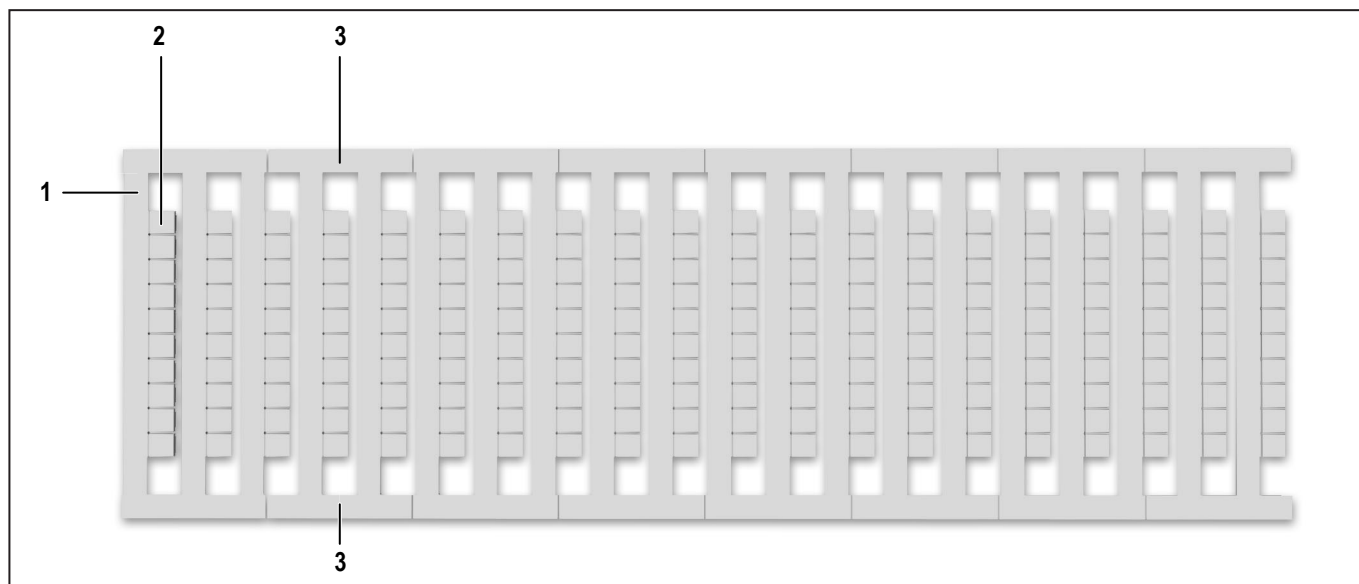



Figure 3.8 Description of the MultiCard

- 1 First project marker surface
- 2 Marker area
- 3 Side strip

# 4 Setup

## 4.1 Unpacking

	<b>CAUTION</b>
	<b>Crush hazard during transport!</b> Due to its weight, the printer must be transported by two people. Always hold the printer at the front and rear when transporting it.

<b>ATTENTION</b>
<b>Damage to property!</b> If transported improperly, ink may leak and soil or damage the device. Always transport the printer in a horizontal position.

- ▶ Open the transport packaging.
- ▶ Take out all the accessories.
- ▶ Two people must lift the printer with the polystyrene packaging material out of the box.
- ▶ Remove the polystyrene packaging material.

 Keep the original packaging for any future transport.



Figure 4.1 Transport restraint

- ▶ Remove the transport restraint (1) from the ink tank lid.

## 4.2 Scope of supply

When you have taken the printer and all the accessories out of the packaging, make sure that the delivery is complete:

- PrintJet **CONNECT**
- 1 set of ink cartridges
- Power cable
- USB cable
- LAN cable
- 1 MultiCard DEK 5/5
- 2 PrintJet Cleaner cloths
- Quick guide for downloading the M-Print® PRO marking software and the user manual

The ink cartridges are supplied separately and are not installed in the printer. The printer is flushed with fluid.

## 4.3 Installing the printer

<b>ATTENTION</b>
<b>Damage to property!</b> Do <b>not</b> use the printer near potential electromagnetic interference fields, such as speakers or base stations of cordless phones. They can negatively affect correct functionality of the printer. Place the printer on a flat, stable surface. The printer will not operate properly if it is tilted or at an angle. Avoid locations where the printer is exposed to great fluctuations in temperature and humidity, direct sunlight, strong exposure to light, excessive heat, and high dust levels. Avoid locations that are subject to impact shocks or vibrations. Avoid transmission of vibrations.

 Observe the necessary operating and maintenance intervals.

- ▶ Place the printer on a surface that extends beyond the base area of the printer on all sides.
- ▶ Leave enough space in front of the printer's output rail.
- ▶ Ensure a sufficient supply of air around the printer.

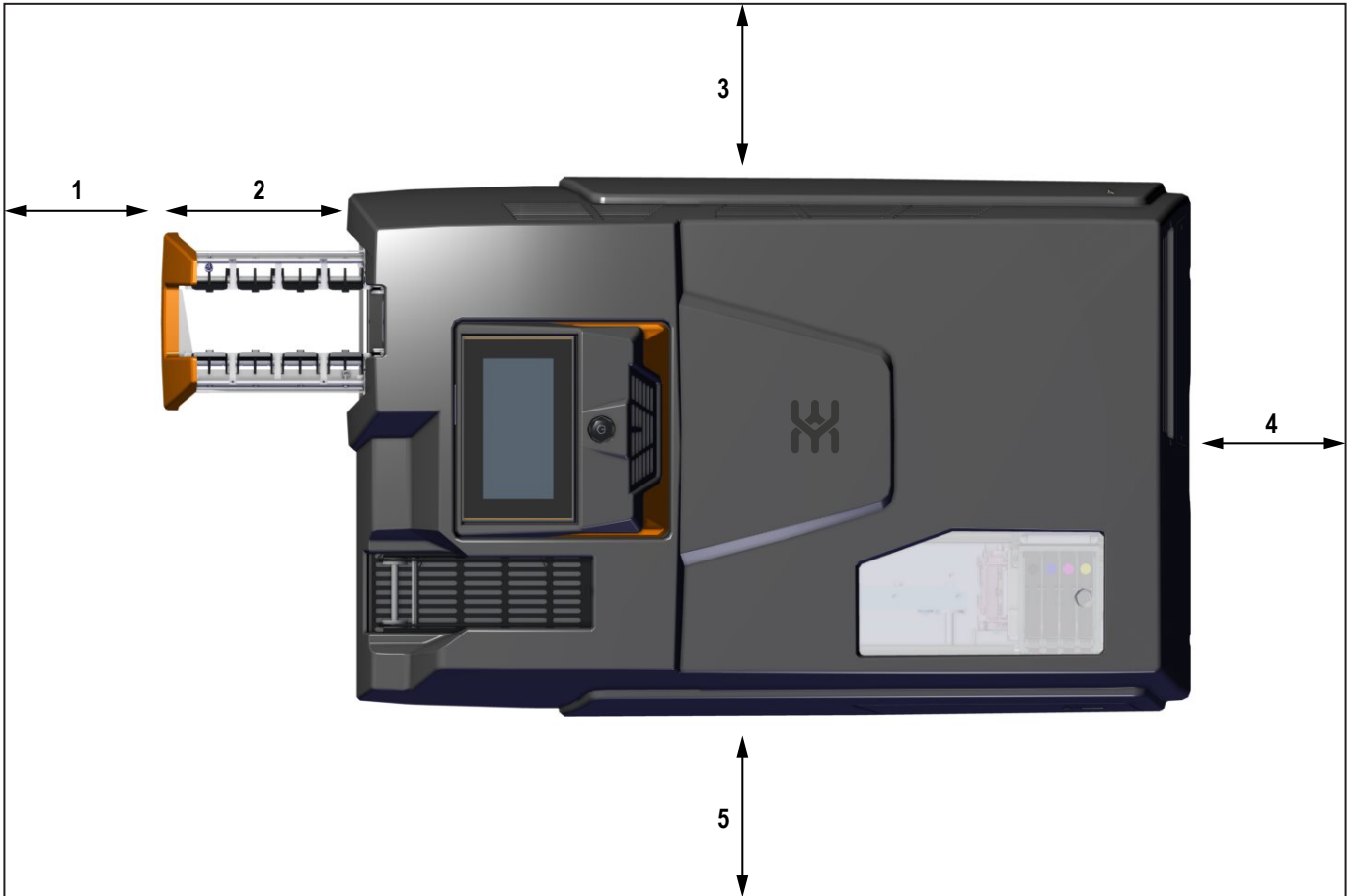

Figure 4.2 Operating and maintenance intervals

- 1 250 mm
- 2 203 mm output rail
- 3 100 mm
- 4 100 mm
- 5 100 mm

#### 4.4 Extracting the output magazine

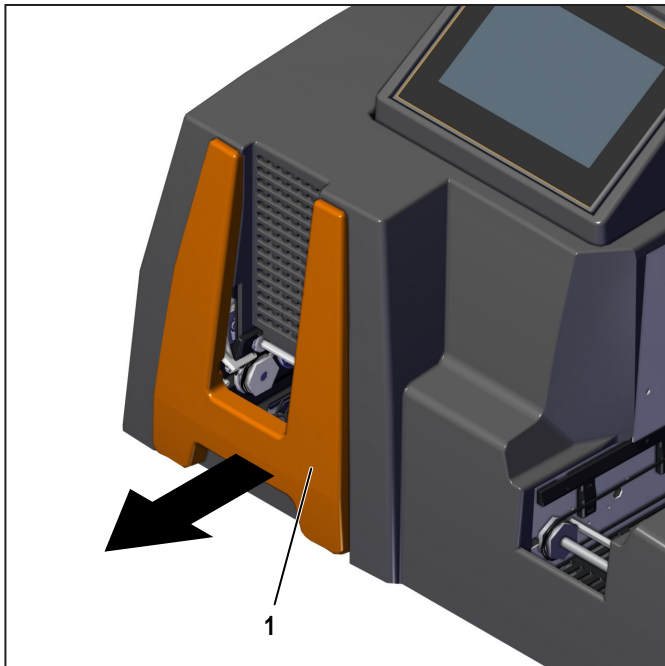

Figure 4.3 Extract the output magazine

- ▶ Extract the output magazine until it clicks into place.
- ▶ Fold down the lifting element fully (in two locking steps).

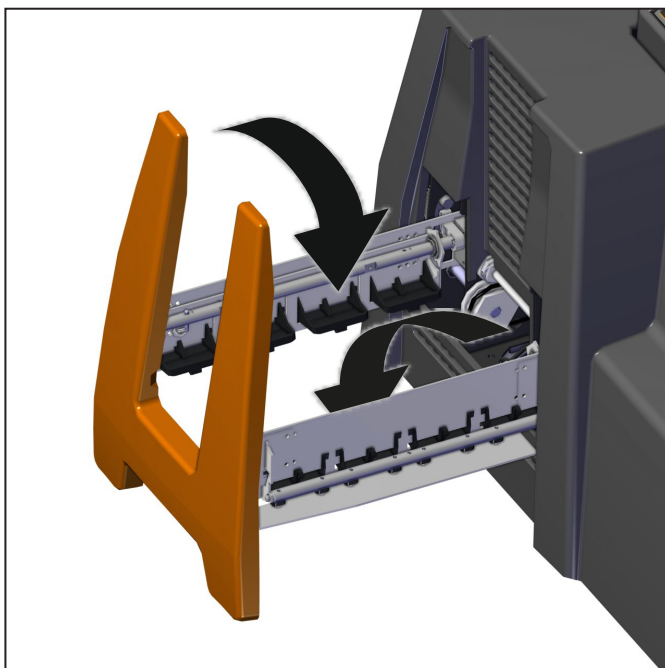

Figure 4.4 Lifting element

#### 4.5 Aligning the touch panel

The touch panel can be aligned in three positions.

- ▶ Pull the touch panel (1) upward.

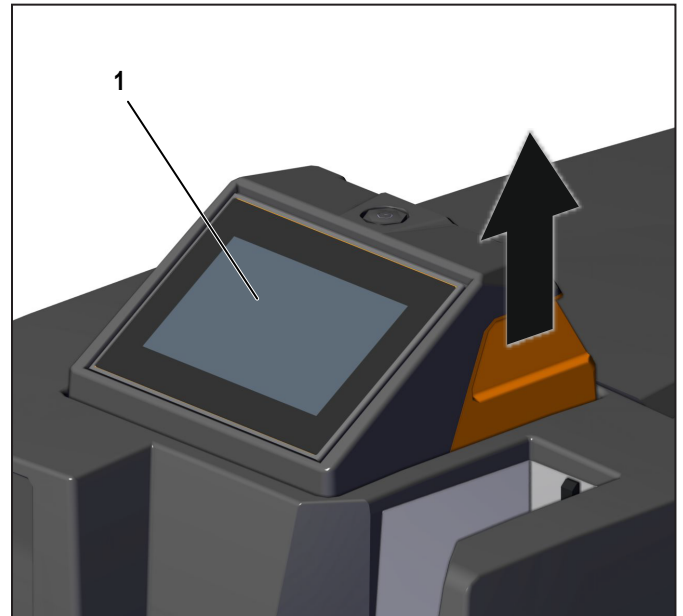

Figure 4.5 Touch panel in position "Operation short side"

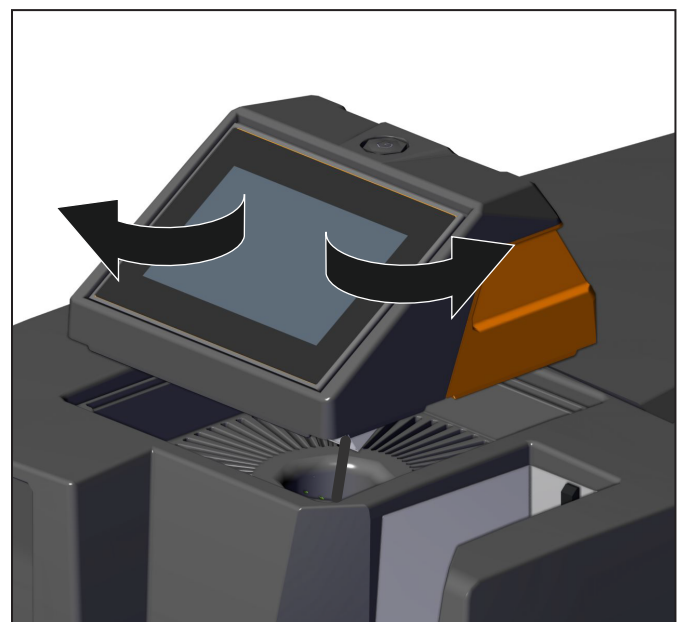

Figure 4.6 Touch panel pulled upward

- ▶ Turn the touch panel 90° to the left or right and let it click into place again.

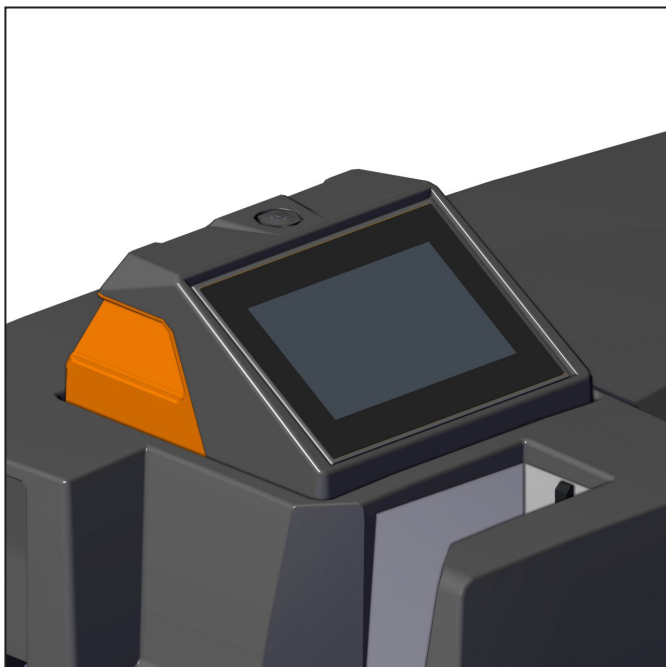



Figure 4.7 Touch panel in position "Operation long side"

## 4.6 Connecting the printer

<b>DANGER</b>	
	<p><b>Warning of electrical hazard!</b></p> <ul style="list-style-type: none"> <li>▶ Make sure that the mains voltage used corresponds to the mains voltage indicated on the printer's rating plate.</li> <li>▶ Only connect the printer to a properly grounded and separately fused socket.</li> <li>▶ Do <b>not</b> connect the printer to either a switch-operated or a timer-controlled socket.</li> <li>▶ When using an extension cable, make sure that the rated current value of the printer does not exceed the ampere rating of the extension cable.</li> <li>▶ When connecting the printer to the power supply, make sure that the building installation is protected with an appropriate fuse.</li> </ul>

<b>DANGER</b>	
	<p><b>Warning of electric shock and fire due to damaged power cables!</b></p> <ul style="list-style-type: none"> <li>▶ Make sure that the power cable is not damaged.</li> <li>▶ Leave the power cable in its original condition.</li> <li>▶ Do not place any objects on the power cable.</li> <li>▶ Make sure that there are no kinks or bending points along the cable.</li> <li>▶ Do not pull the plug out of the socket by the cable.</li> </ul>

### 4.6.1 Wired connection

The printer can be connected to the PC via the USB cable or to the local network via the network cable (see chapter 3.1.2 on page 14).

- ▶ Connect the printer to a nearby socket.
- ▶ Make sure that the socket is easily accessible.
- ▶ Make sure that the plugs are fully inserted into the connection socket of the printer and into the socket.
- ▶ Lay the cables so that there are no tripping hazards.



Do not connect the USB cable until you have installed the M-Print® PRO marking software.

### 4.6.2 Wireless connection

The printer can be connected to the local network via the WLAN USB stick (see chapter 3.1.2 on page 14).

## 4.7 Turning on the printer / Switching the printer to standby mode

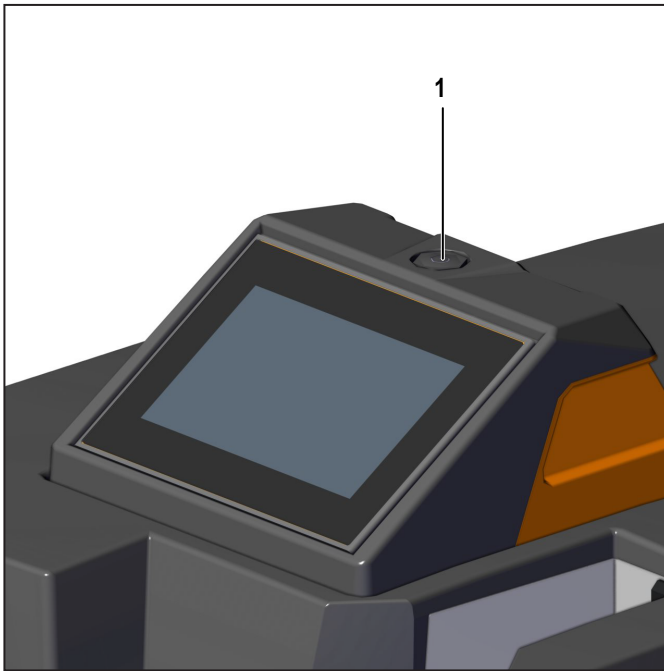

Figure 4.8 Turning on the printer

1 Standby button

### 4.7.1 Turning on

- ▶ Turn on the printer at the main switch on the rear of the device (see chapter 3.1.2 on page 14).

The standby button lights up green:

- The printer is ready for operation.
- The printer has no current print job.

The standby button lights up orange:

- The printer is in standby mode.
- The printer is processing a current print job.

### 4.7.2 Switching to standby mode

- ▶ Press the standby button (1) for three seconds to switch the printer to standby mode.

The standby button lights up orange. Only the print head, including the control, is now supplied with power. This allows the print head to be supplied with ink to prevent it drying out.

## ATTENTION

### Damage to property!

Turning off the printer at the main switch on the rear of the device can cause the ink nozzles to clog. Automatic cleaning after turning the printer back on again becomes necessary.

- ▶ Do not turn off the printer.
- ▶ Keep the printer in standby mode.
- ▶ If the printer will be out of operation for more than three weeks, set the printer to downtime mode (see main menu **Maintenance**)

## 4.8 Inserting ink cartridges

CAUTION	
	<p><b>Warning of hand injuries due to sharp objects!</b></p>
	<p>Open the ink tank lid carefully to avoid stab injuries.</p>

Upon delivery, there are no ink cartridges in the printer.

- ▶ Observe the following information:
  - Do not open the ink cartridge packaging until just before inserting the ink cartridge into the printer.
  - New ink cartridges are covered with a protective film at the ink outlet. Do not remove this protective film. The protective film is punctured when the ink cartridge is inserted and remains on the ink cartridge.
  - The ink cartridges must not be shaken, disassembled or refilled.
  - Store unopened ink cartridges in a cool and dry location (recommended 4°C). Before use, the ink cartridges should be warmed to room temperature for at least three hours.

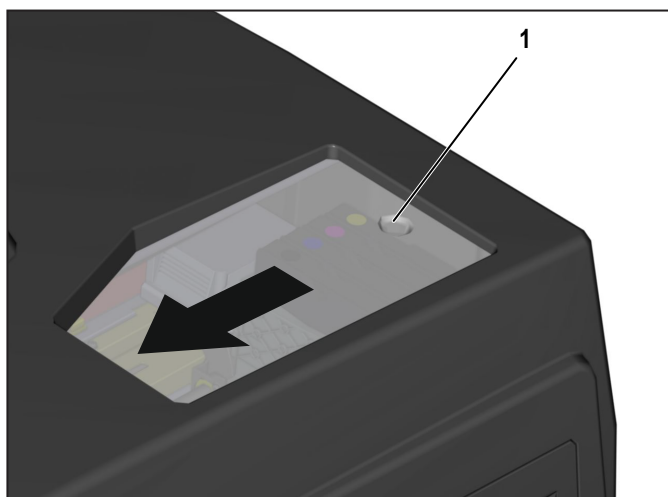

Figure 4.9 Opening the ink tank lid

- ▶ Push the ink tank lid (1) in the direction of the arrow.
- ▶ Remove the four blue protective caps from the ink supply outlets.
- ▶ Never touch the ink supply outlet.

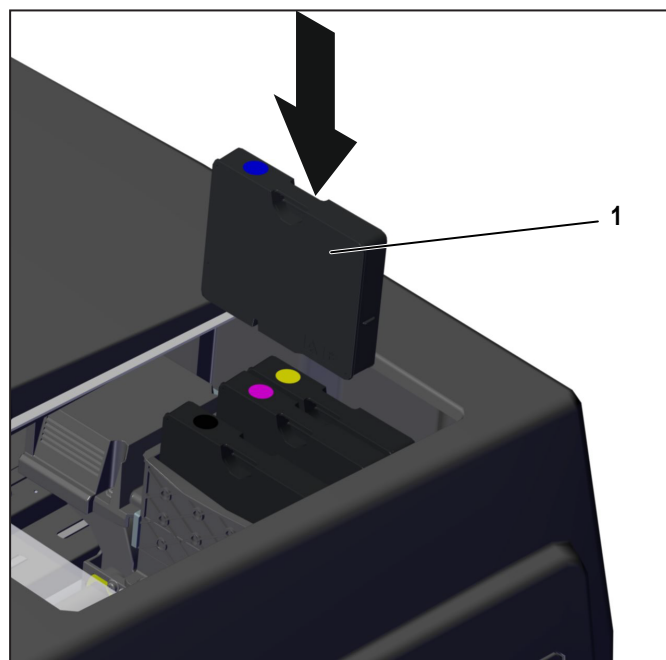

Figure 4.11 Inserting an ink cartridge (example: Cyan ink cartridge)

- ▶ Place each ink cartridge (1) in the designated position. Make sure that each ink cartridge clicks into place.
- ▶ Close the ink tank lid.

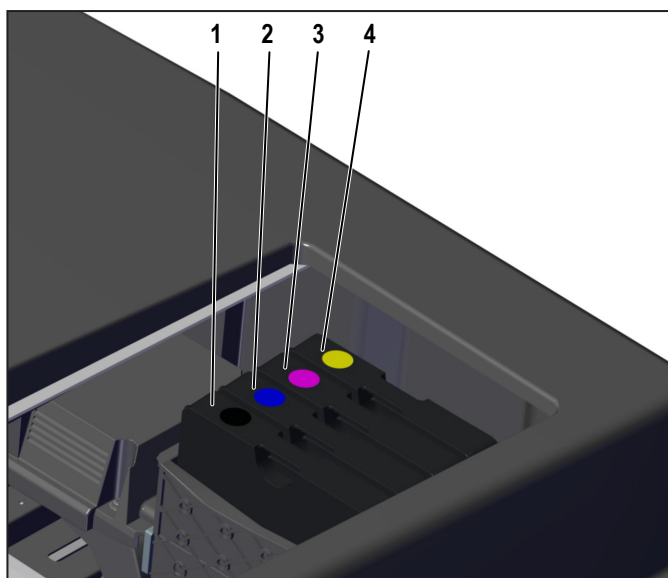

Figure 4.10 Positions of the ink cartridges

- 1 Black ink cartridge
- 2 Cyan ink cartridge
- 3 Magenta ink cartridge
- 4 Yellow ink cartridge

## 4.9 Language selection on the touch panel

When turning on the printer, the main menu **System status** is displayed on the touch panel.

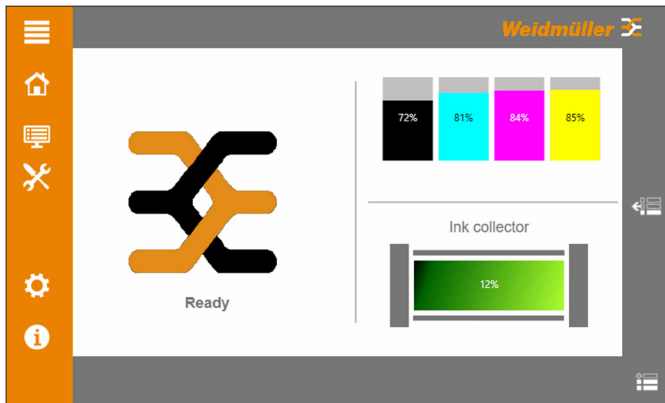

Figure 4.12 Main menu System status

- ▶ Select the main menu **Settings**.
- ▶ Tap the submenu **Language**.



Figure 4.13 Submenu Language

- ▶ Select the required language.
- The language is changed without restarting the control.

## 4.10 Installing the M-Print® PRO marking software

The marking system has been designed for operating systems Microsoft Windows® (32-bit version / 64-bit version).



Have the installation carried out by skilled personnel. Administrator rights are required for this process. You can find information about the marking software in the M-Print® PRO user manual.

The M-Print® PRO software can be downloaded free of charge from the online shop (<https://eshop.weidmueller.com>).

The article page can be opened by entering the article name or article number 1905490000 in the search bar. Under the menu item "Software support", you will find a download link for the current version.

- ▶ Start the downloaded program.

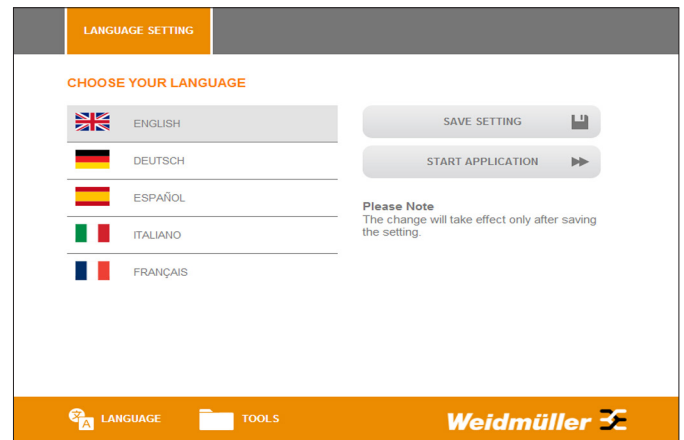

Figure 4.14 M-Print® PRO installation - Language setting

- ▶ Click the required language.
- ▶ Click **START APPLICATION**.



Figure 4.15 M-Print® PRO installation - Start menu

- ▶ Click **SOFTWARE**.



Figure 4.16 M-Print® PRO installation - Software

- ▶ Click **M-Print® PRO (MULTILINGUAL)**.
- ▶ Select the required language.  
The installation process starts automatically and the setup wizard is displayed on the screen.
- ▶ Click **Next**.  
The terms of the license agreement are shown.
- ▶ Accept the terms of the license agreement and click **Next**.
- ▶ Select the type of installation:

Type of installation	Description
Typical	The M-Print® PRO marking software is installed with the most common features.

Type of installation	Description
Custom	The M-Print® PRO marking software is installed; add-on modules can be selected/deselected.
Complete	The M-Print® PRO marking software and all add-on modules are installed automatically.
Network	The M-Print® PRO marking software is installed on a shared drive on the network and can be used by multiple users.

- ▶ Click **Typical** if, for example, you want to install the software with the most common features.
- ▶ Click **Install**.  
The installation status is shown by the progress bar.
- ▶ When installation has been completed, click **Finish**.

#### 4.10.1 M-Print® PRO - Configuring single-user installation

The single-user installation is used when control takes place from a PC. The M-Print® PRO marking software is installed on the PC.



Have single-user installation and configuration carried out by skilled personnel. You can find information on the configuration in the user manual for the M-Print® PRO software and in document `printersetup.pdf`.

#### 4.10.2 M-Print® PRO - Configuring network installation

Network installation is used when several users are to work with the M-Print® PRO marking software in one network. Instead of installing M-Print® PRO on each of their computers, here it is only necessary to install the software centrally on a server or central PC. The client PCs access M-Print® PRO via shared network paths.



Have network installation and configuration carried out by skilled personnel. Administrator rights are required for this process. You can find information about the configuration in the document `printersetup.pdf`.

## 4.11 Setting up and adjusting a MultiCard for the printer

To set the correct print position for a MultiCard and to compensate for physical changes to it, you must make some settings via the M-Print® PRO marking software. You can find detailed information in the user manual for the M-Print® PRO marking software.

## 4.12 Running a print test

You can run a print test after turning on the printer.

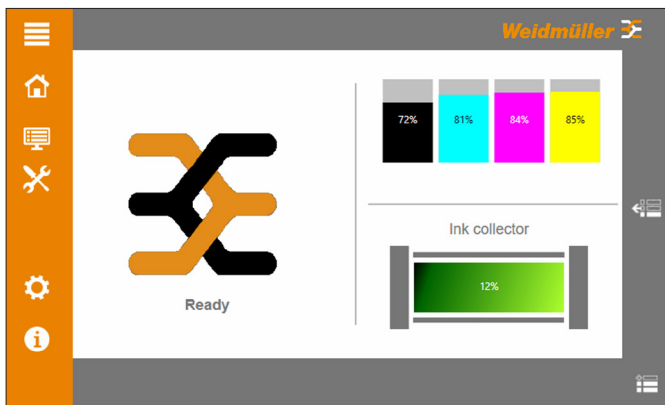

Figure 4.17 Touch panel - Main menu System status

- ▶ In the main menu **Jobs**, select the submenu **Demo print jobs**.
- ▶ Choose a template that corresponds to the supplied MultiCard.

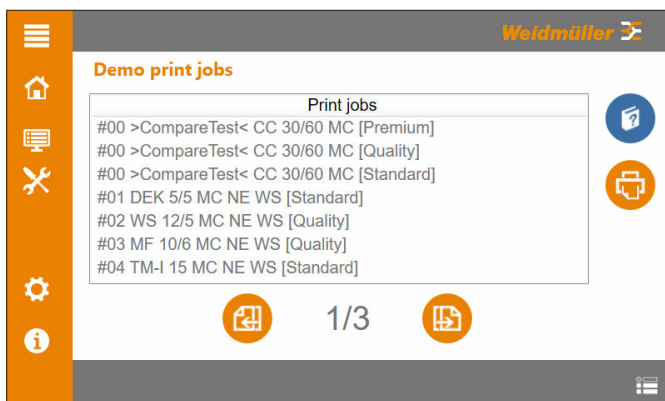



Figure 4.18 Submenu Demo print jobs

- ▶ Insert the MultiCard into the input magazine.
- ▶ Click **Print** to start printing.

# 5 Operation

## 5.1 Information about operation

	<b>CAUTION</b>
	<p><b>Warning of crush hazard!</b></p> <p>Do not operate the printer without its enclosure and do not reach through its openings while it is running.</p>

	<b>CAUTION</b>
	<p><b>Warning of automatic start-up</b></p> <p>The printer can start up at any time without warning when a print job is sent over the network.</p>

	<b>CAUTION</b>
	<p><b>Warning of hot surface!</b></p> <p>Contact with hot components of the output magazine and cards can cause burns.</p> <ul style="list-style-type: none"> <li>▶ Make sure that all components have cooled down to ambient temperature before carrying out any work on the output magazine.</li> <li>▶ Let the cards cool down before removing them from the output magazine.</li> </ul>

<b>ATTENTION</b>
<p><b>Damage to property!</b></p> <p>Using expired ink reduces the print quality and may cause damage to the printer.</p>

- ▶ Observe the following information:
  - The openings in the printer enclosure must not be blocked or covered.
  - Do not insert any objects into openings.
  - Make sure that no liquid gets into the printer.
  - Do not turn off the printer! The printer automatically switches to standby mode.

The operating parameters are only retained while the printer is turned on. These parameters ensure, for example, that the print head is cleaned optimally.

### 5.1.1 Longer downtimes

If the printer is turned off and de-energized or is not used, this can lead to clogging of the ink nozzles after a certain amount of time.

- Leave the printer turned on when not used for roughly three weeks.
- Replace the ink cartridges with fluid cartridges if you do not use the printer for more than three weeks (see chapter 8 on page 56).

The fluid ensures that the ink-bearing components (e.g. lines and nozzles) do not dry up.

### 5.1.2 Shelf life of the ink

Removing the ink cartridges can cause leaks in the connection between the ink cartridge and the ink line. This can lead to a faulty ink feed system.

- Only remove an ink cartridge when it is empty or out of date.
- Do not use out-of-date ink. If the use-by date of the ink is almost reached, a message is displayed on the touch panel. Replace the specified ink cartridge (see chapter 6.4 on page 43).
- Only use products that have been produced or approved by Weidmüller (M-Print® PRO, MultiCards/MetalliCards, and ink cartridges). Otherwise, no liability can be assumed for the print quality and durability.



Printer faults and damage caused by the use of unapproved and unsuitable accessories and consumables are excluded from the warranty.

## 5.2 Inserting MultiCards / MetalliCards

### MultiCard

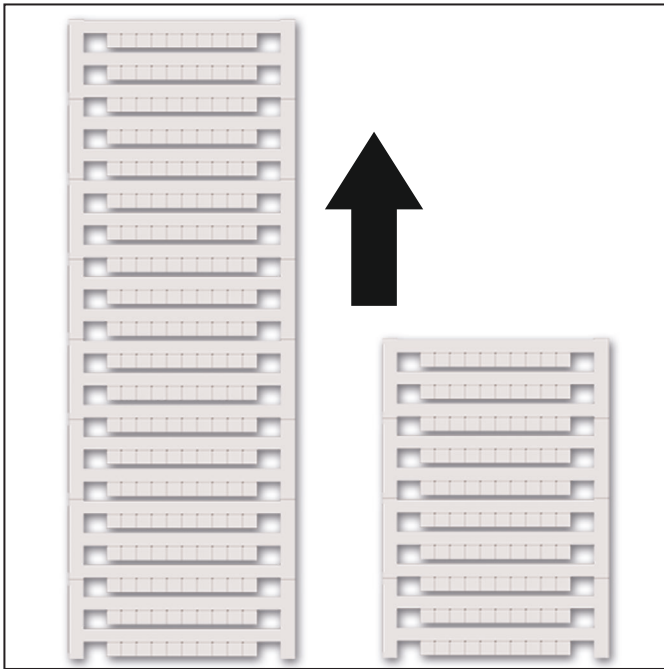

Figure 5.1 Direction of insertion for MultiCards

MultiCards can be inserted directly without any pretreatment.

- ▶ Insert the MultiCard ensuring that the side with the closed strip is facing the printer.

### MetalliCard

- ▶ Remove the protective film from the MetalliCard.
- ▶ Clean the MetalliCard with a moist cloth (Primer CC-M – 2068020000).
- ▶ Hold the MetalliCard at the sides when inserting it into the inlay. Do not touch the area to be printed as that reduces the print quality.

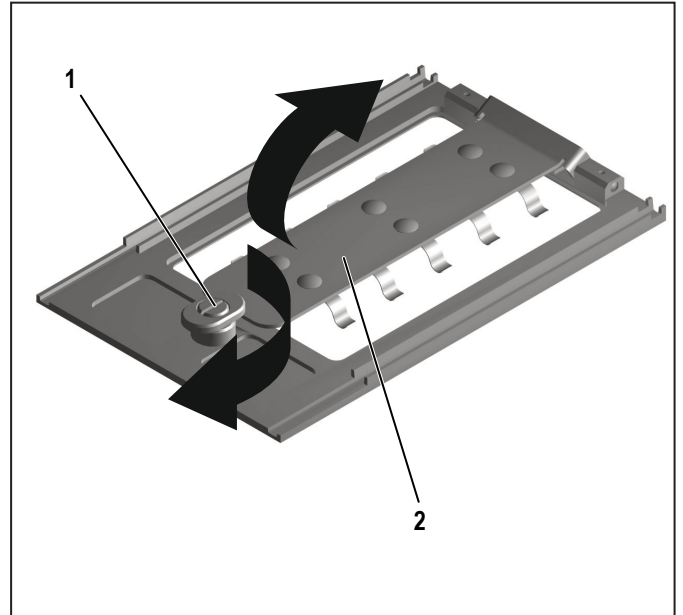

Figure 5.2 Opening the inlay

- ▶ Open the inlay's lock (1) and raise the bar (2).

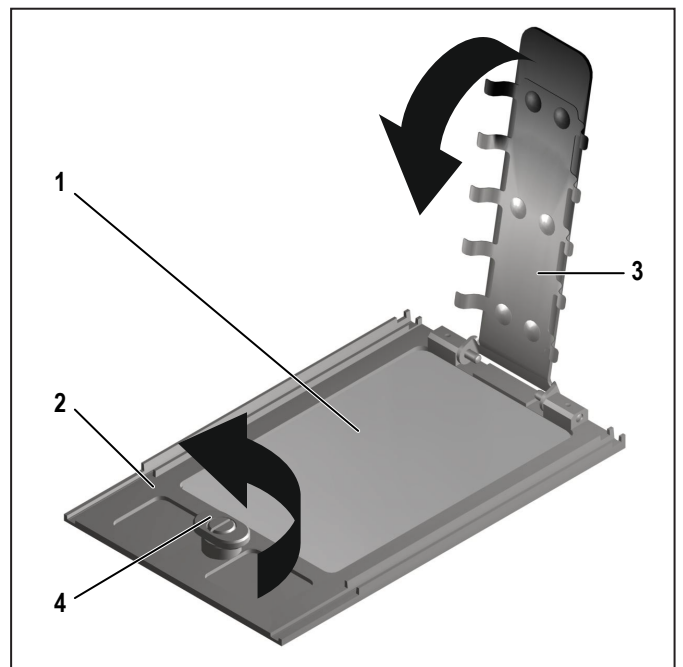

Figure 5.3 Inserting a MetalliCard into the inlay

- ▶ Insert the MetalliCard (1) into the inlay (2).
- ▶ Lower the bar (3) and close the lock (4).

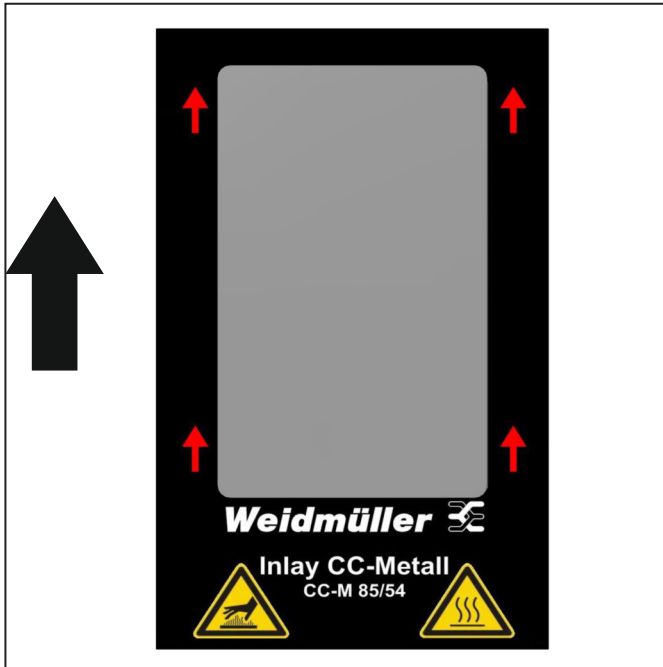

Figure 5.4 Direction of insertion for MetalliCards

### 5.2.1 Processing a stack of MultiCards



- MultiCards may only be inserted in stacks.
- You can insert a stack of up to max. 50 MultiCards into the magazine. The stack must not exceed 50 MultiCards.
- Do **not** mix half and whole MultiCards in a stack.
- Half MultiCards **cannot** be stacked in the output magazine.

- ▶ Insert the stack of MultiCards (1) into the magazine (2) in the direction of insertion shown previously.

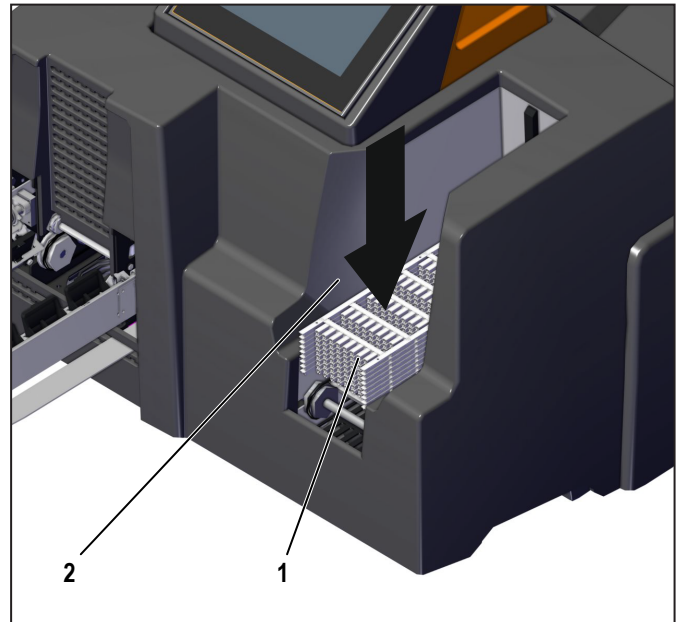

Figure 5.5 Inserting stacks of MultiCards

### 5.2.2 Processing a single MetalliCard

- ▶ Place a single MetalliCard (1) on the transport belts (2) in the direction of the arrow.

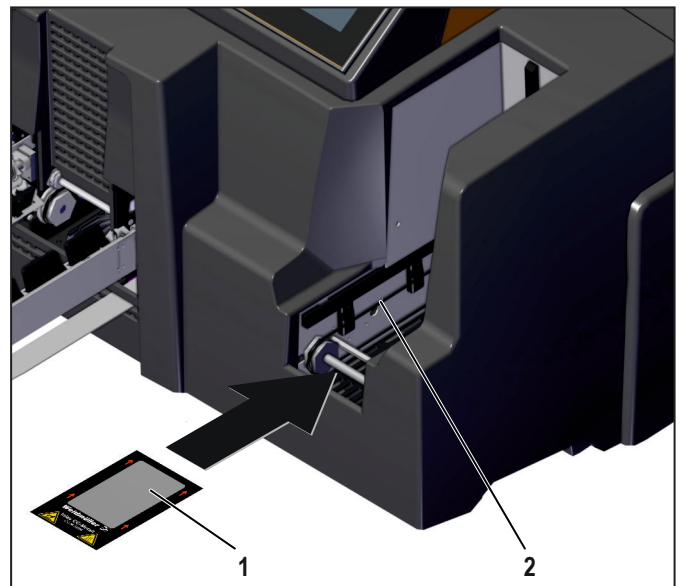

Figure 5.6 Inserting MetalliCard inlays individually

Single MultiCards can be inserted in the same way as when processing single MetalliCards.

### 5.3 Software settings

The M-Print® PRO marking software is used to assign and calibrate the printer.



To determine the settings, a MultiCard must be printed. The MultiCard is not cured in this process. The printed MultiCard can be cleaned with cold water and used again.

You can find further information about the settings in the user manual for the M-Print® PRO marking software.

### 5.4 Automatic adjustment

You can select the option for automatic adjustment of the MultiCards in the M-Print® PRO marking software.



You can find further information about the settings in the user manual for the M-Print® PRO marking software.

### 5.5 Printing MultiCards/MetalliCards

- ▶ Start the M-Print® PRO marking software.
- ▶ Select the required MultiCard/MetalliCard.
- ▶ Enter the text or insert an image or barcode that you want to print.
- ▶ Insert the MultiCard/MetalliCard or the MultiCard stack.
- ▶ Start printing via M-Print® PRO.

You can also save the print job in M-Print® PRO on a USB stick and link it to the printer's USB port. The print job is then selected and started on the touch panel (see Operation on the touch panel in the submenu **USB stick print jobs**).



You can find further information about printing in the user manual for the M-Print® PRO marking software.

#### 5.5.1 Curing settings/Heating level

The settings for curing MultiCards and MetalliCards differ and are applied automatically. You can set a higher or lower intensity for curing. After cooling, check each MultiCard or MetalliCard for resistance to smudging and scratching.



You can find further information about the fine adjustment of the heating level in the user manual for the M-Print® PRO marking software.

#### 5.5.2 Selecting the print quality

The print quality is influenced by three different parameters: Resolution, color profile, and preheating.

##### Resolution

Print quality	Resolution / application
Speed Print	300 dpi, single print: Printing with max. print speed
Quality Print Text	600 dpi, single print: Printing alphanumeric data
Quality Print Graphic	600 dpi, triple print: Printing graphics
Premium Print	1200 dpi, double print (MultiCard), triple print (MetalliCard): Printing with the best quality possible

##### Color profile

Text, Graphic, Optimized

##### Preheating

Activating/deactivating preheating, setting the preheating time

The printer prints with the CMYK color profile. The waste heat generated during printing is used to pre-heat the cards in the input magazine. The longer the cards are preheated, the higher the print quality. The time for preheating the cards is configured in the M-Print® PRO marking software.

You can choose between Speed Print (possibly without preheating time), Quality Print Text, Quality Print Graphic and Premium Print (for longer preheating times for each individual card).



You can find further information about determining the print quality in the user manual for the M-Print® PRO marking software.

## 5.6 Settings on the touch panel

The touch panel can be rotated through 90° and 180° horizontally and can be locked in three positions (see chapter 4.5 on page 24). It has a 7" color display with symbols, graphics, web and QR codes, controls, and widgets.

The touch panel enables advanced printer control and print job monitoring with information on printer settings and print jobs as well as animated help functions for operation, maintenance, and service work.

The following settings are made on the touch panel:

- Setting the desired language for the touch panel
- Viewing, printing, and deleting print jobs
- Printing templates
- Receiving information about the printer, e.g. ink cartridge levels, requests for maintenance work
- Carrying out maintenance operations

### 5.6.1 System status

The main menu **System status** displays the current status of the printer: Readiness, fill level of the ink cartridges and the ink collector, and current print jobs.

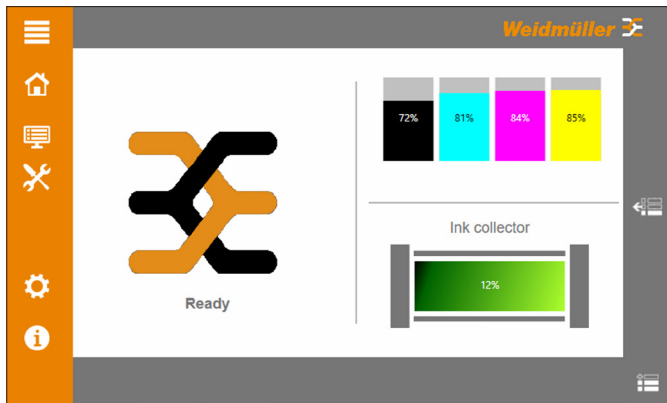

Figure 5.7 Main menu System status

► Tap **Show print jobs**.

Up to 50 print jobs that are currently loaded are displayed.



Figure 5.8 Current print jobs

### 5.6.2 Current jobs

The submenu **Current jobs** displays the print jobs that were sent to the printer in M-Print® PRO. The sequence of the print jobs can be changed. Print jobs can be deleted. The current status of the print jobs is displayed.

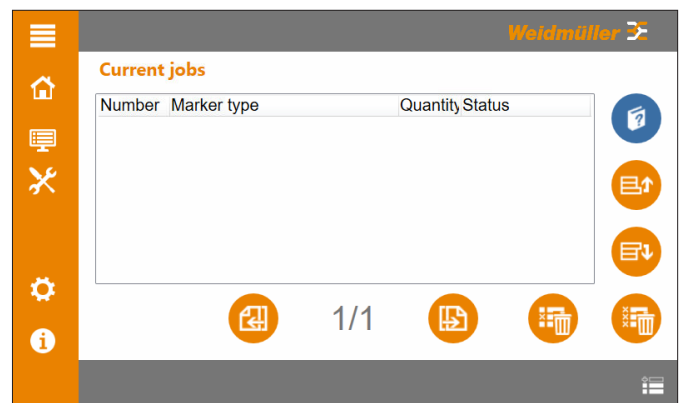

Figure 5.9 Submenu Current jobs

### 5.6.3 Print job history

The submenu **Print job history** displays the executed print jobs. Executed print jobs can be printed repeatedly.

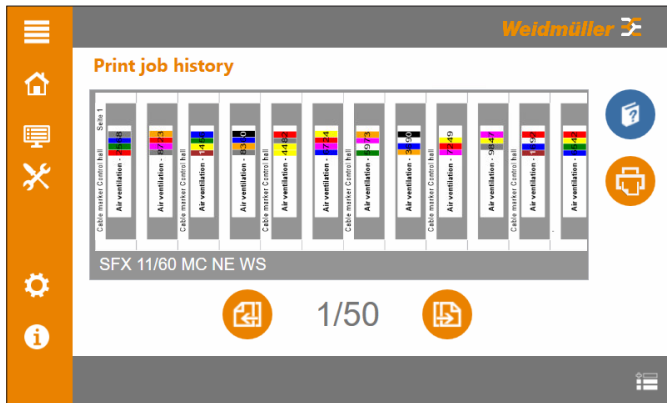

Figure 5.10 Submenu Print job history

### 5.6.4 Demo print jobs

The submenu **Demo print jobs** displays preconfigured print jobs for demonstration purposes. Preconfigured print jobs can be printed.



Figure 5.11 Submenu Demo print jobs

### 5.6.5 USB stick print jobs

In the submenu **USB stick print jobs**, print jobs in M-Print® PRO can be exported and saved on a USB stick. The USB stick is connected to the printer. The print jobs are listed and can be executed.

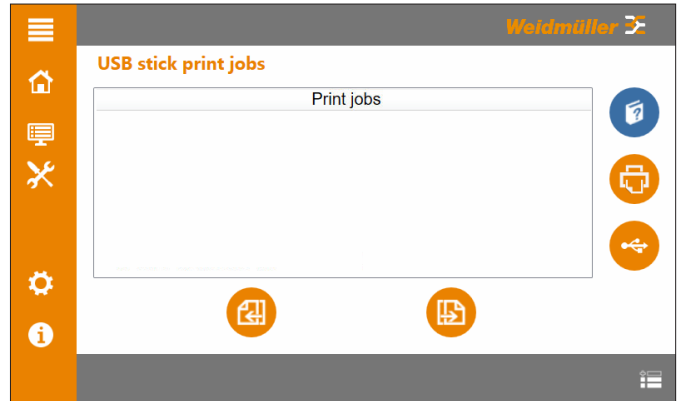

Figure 5.12 Submenu USB stick print jobs

► Export the print jobs in M-Print® PRO to a USB stick.

➔ You can find further information about exporting print jobs in the user manual for the M-Print® PRO marking software.

► Connect the USB stick to the printer. The print jobs stored on the USB stick are loaded.

### 5.6.6 Interfaces / Ethernet settings

➔ Have the installation carried out by skilled personnel. Administrator rights are required for this process.

In the submenu **Ethernet settings**, communication with the network is established via a LAN cable.

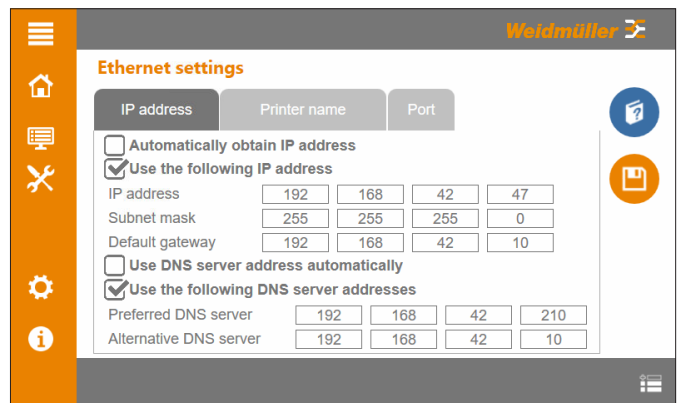

Figure 5.13 Submenu Ethernet settings

### IP address

You can either activate dynamic address assignment (DHCP) **Obtain an IP address automatically** or static address assignment **Use the following IP address**.

Dynamic address assignment (DHCP):

- The DHCP server must be accessible in the network.
- The IP address and subnet mask are automatically obtained from the DHCP server.
- In the case of dynamic IP address assignment, the printer may have a different IP address when it is restarted.

Static address assignment:

- The entered IP address and subnet mask are static values that do not change for the printer.
- The data for the IP address and subnet mask must be entered manually.

- ▶ Select the type of IP address assignment.

You can either obtain the DNS server address automatically (activation: **Obtain an IP address automatically**) or enter the DNS server address manually (activation: **Use the following DNS server addresses**).

- ▶ Select the reference of the DNS server address.

### Printer name

The preset printer name is always the serial number. You can assign a different name to the printer, e.g., to be able to identify it better.

- ▶ To do so, enter a new name via the virtual keyboard and confirm your entry.

### Port

The preset port is "8181". You can change the port depending on the network protocol.

- ▶ To do so, enter the port via the virtual keyboard and confirm your entry.
- ▶ Click **Save** to save the settings.

## 5.6.7 Interfaces / WiFi settings



Have the installation carried out by skilled personnel. Administrator rights are required for this process.

In the submenu **WiFi settings**, communication with the network is established via WLAN.

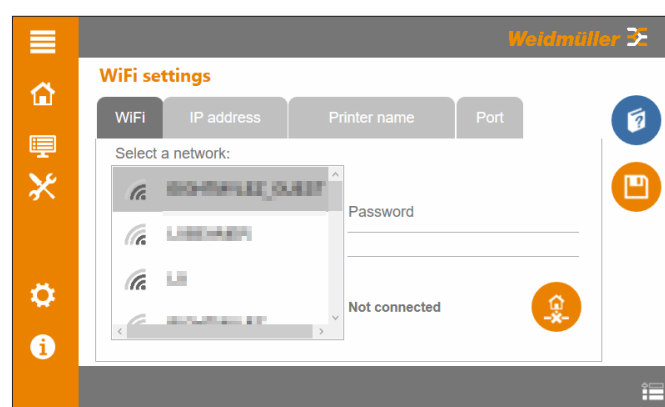

Figure 5.14 Submenu WiFi settings

### WiFi

The selection window **Select a network ...** lists the available WLAN networks.

- ▶ Select the WLAN network.
- ▶ Enter the user name and password for the selected WLAN network.
- ▶ Tap the function element **Connect**.



For information about IP address, printer name, and port settings, see chapter 5.6.6 on page 36.

- ▶ Click **Save** to save the settings.

## 5.6.8 Interfaces / USB connection



Have the installation carried out by skilled personnel. Administrator rights are required for this process.

In the submenu **USB connection**, communication with the network is established via a USB connection.

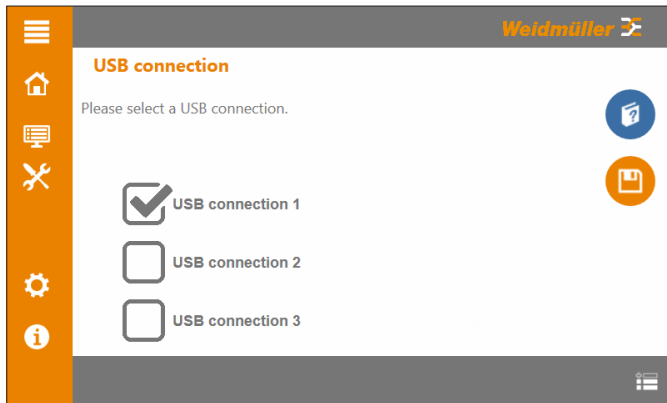

Figure 5.15 Submenu USB connection

Print jobs can be sent from the PC to a maximum of three printers via the "USB" interface (for configuration of the USB interfaces at the PC, see M-Print® PRO user manual).

- ▶ Configure the USB connection in M-Print® PRO and activate the corresponding USB connection ("USB connection 1", "USB connection 2" or "USB connection 3").
- ▶ Click **Save** to save the settings.

### 5.6.9 Language

In the submenu **Language**, you can set the language of the user interface.



Figure 5.16 Submenu Language

- ▶ Select the required language.  
The language is changed without restarting the control.

### 5.6.10 Advanced settings

In the submenu **Advanced settings**, security settings and printer settings are carried out.

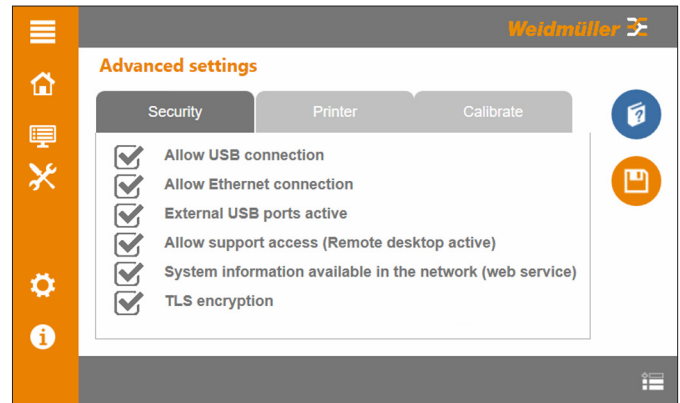

Figure 5.17 Submenu Advanced settings

#### Security

The following settings can be activated or deactivated:

- **Allow USB connection**  
Activates PC/printer communication via USB (USB cable).
- **Allow Ethernet connection**  
Activates PC/printer communication via Ethernet (LAN cable).
- **External USB ports active**  
Activates PC/printer communication via WLAN (WLAN USB stick, USB data stick).
- **Allow support access (Remote Desktop active)**  
Service work through Weidmüller: Allows control of the printer via Remote Desktop.
- **System information available in the network (web service)**  
Enables querying of the system settings after entering the printer IP address in the web browser.
- **TLS encryption**  
Network security: Activates TLS encryption (recommendation).

#### Printer

Print jobs can be deleted automatically when the printer is turned off at the main switch. When turning the printer back on, there are no longer any print jobs in the "Current print jobs" list.

- ▶ Activate the function if print jobs are to be deleted.
- ▶ Click **Save** to save the settings.

#### Calibrate

The print image can be optimized by calibrating the print heads (Calibration of the print heads, see chapter 6.5.2 on page 45).

### 5.6.11 Support connection

In the submenu **Support connection**, Weidmüller Service can access printer functions and parameter data.

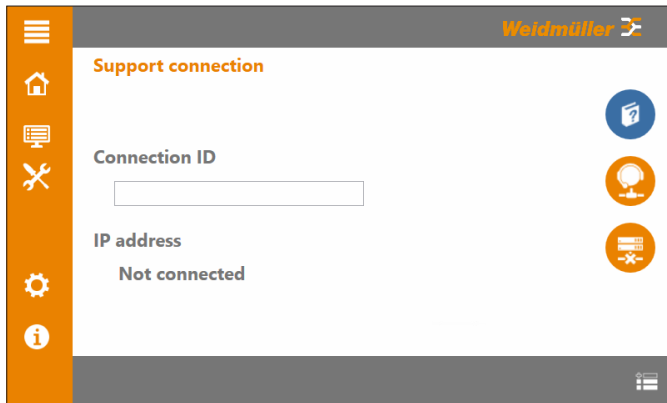

Figure 5.18 Submenu Support connection

To authenticate the printer, the customer receives a connection ID, which only needs to be entered once.

- ▶ Contact Weidmüller Service to receive the connection ID:

Web link:

[https://www.weidmueller.com/int/company/our\\_company/locations/index.jsp](https://www.weidmueller.com/int/company/our_company/locations/index.jsp)

QR code:



- ▶ Use the virtual keyboard to enter the connection ID.
- ▶ Tap **Activate remote maintenance**.

### 5.6.12 User groups

In the submenu **User groups**, the access privileges are selected.

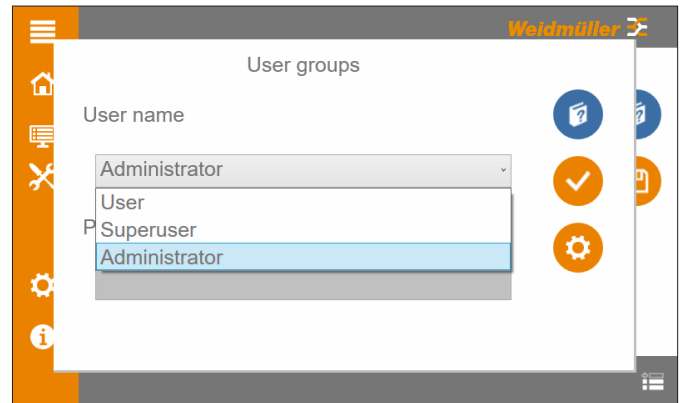

Figure 5.19 Submenu User groups

The printer can be operated with various access privileges. The user has a choice of three user levels (for access privileges and user levels, see chapter 3.2.3 on page 17).

- ▶ Select the user level.
- ▶ Use the virtual keyboard to enter the corresponding password.



The current passwords of the three user levels can only be changed by the administrator.

### 5.6.13 System information

The submenu **System information** provides information on printer parameters and characteristics.

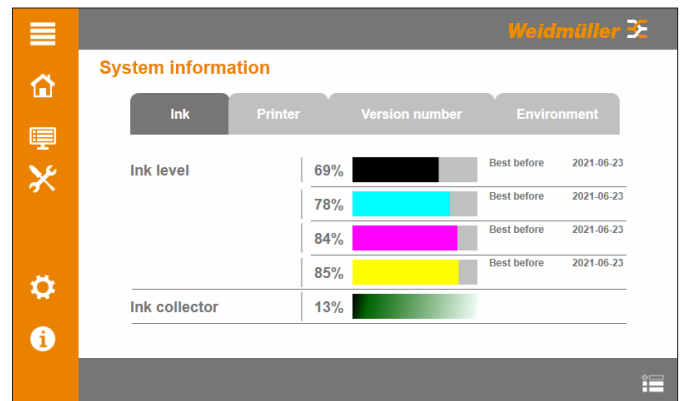



Figure 5.20 Submenu System information

# 6 Cleaning and maintenance

## 6.1 Safety information

	DANGER
	<p><b>Danger of death due to electric shock!</b></p> <p>Never remove the enclosure from the device when carrying out any maintenance and cleaning work.</p>

	CAUTION
	<p><b>Danger of injury!</b></p> <p>Wear your protective equipment during the following maintenance and cleaning work:</p> <ul style="list-style-type: none"> <li>– Manual cleaning of the print heads</li> <li>– Replacing ink cartridges</li> <li>– Replacing ink cartridges with fluid cartridges</li> <li>– Replacing the ink collector</li> </ul>

ATTENTION
<p><b>Damage to property!</b></p> <p>Damage to the printer due to harsh cleaning agents! Do not use any scouring agents or solvents to clean the outer surfaces and the touch panel.</p>

## 6.2 Software-controlled maintenance

The following maintenance work is performed or supported on the touch panel in the main menu **Maintenance**:

- Nozzle check in the submenu **Nozzle check**
- Automatic print head cleaning in the submenu **Print head cleaning**
- Preparing the printer for longer storage in the submenu **Longer downtime**

### 6.2.1 Nozzle check

The nozzle check can be executed in the submenu **Nozzle check**.

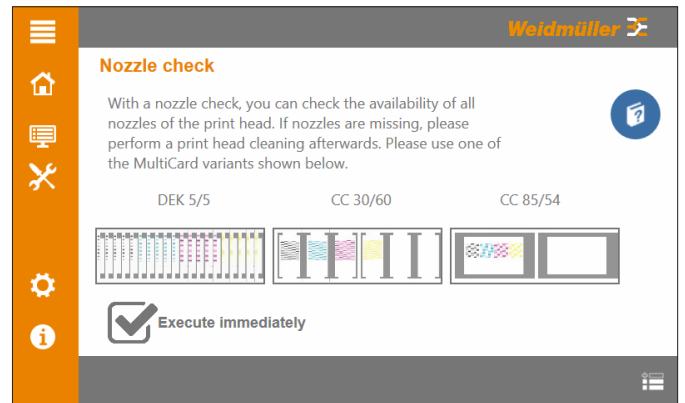

Figure 6.1 Submenu Nozzle check

The nozzle check is used to check correct functionality of the print head nozzles. The nozzle check is loaded into the "Current jobs" list. The nozzle check will be executed as soon as a current print job has been completed.

- ▶ Tap and select the MultiCard variant (example "CC 30/60") for the nozzle check.
- ▶ When inserting the MultiCard for the nozzle check, observe the sequence of the previously inserted MultiCards.

### Print images after the nozzle check

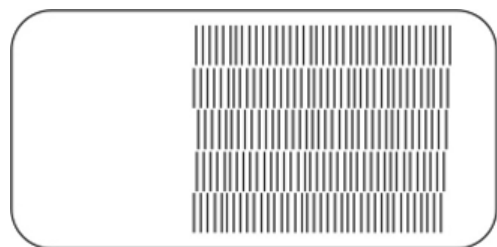

Figure 6.2 Print image: 100% functional nozzles

All the nozzles are fully functional. Print head cleaning is not necessary.

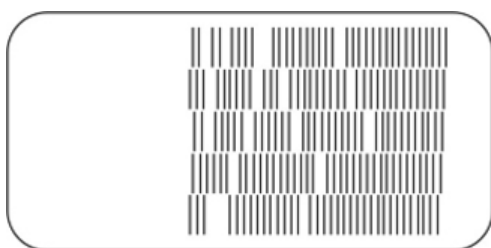

Figure 6.3 Print image: Approx. 90% functional nozzles

Approx. 90% of the nozzles are fully functional:

- ▶ Execute nozzle head cleaning with the setting **Low** (see chapter 6.2.2 on page 41).

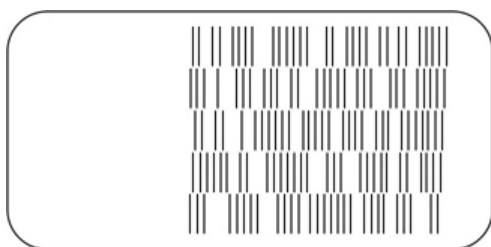

Figure 6.4 Print image: Approx. 75% functional nozzles

Approx. 75% of the nozzles are fully functional:

- ▶ Execute nozzle head cleaning with the setting **Normal** (see chapter 6.2.2 on page 41).



Figure 6.5 Print image: Approx. 50% functional nozzles

Approx. 50% of the nozzles are fully functional:

- ▶ Execute nozzle head cleaning with the setting **Intensive** (see chapter 6.2.2 on page 41).

## 6.2.2 Print head cleaning



Ink is consumed during print head cleaning.

### Fill level of the ink cartridges

Before print head cleaning in the setting **Intensive**, replace the ink cartridges with new cartridges if the fill level is less than 10%.

### Residual capacity of the ink collector

Before print head cleaning, replace the ink collector if the residual capacity is less than 10%.

Ink consumption during print head cleaning:

- Setting **Low** Approx. 0.5%
- Setting **Normal** Approx. 1.0%
- Setting **Intensive** Approx. 7.0%

The print heads can be cleaned automatically in the sub-menu **Print head cleaning**.

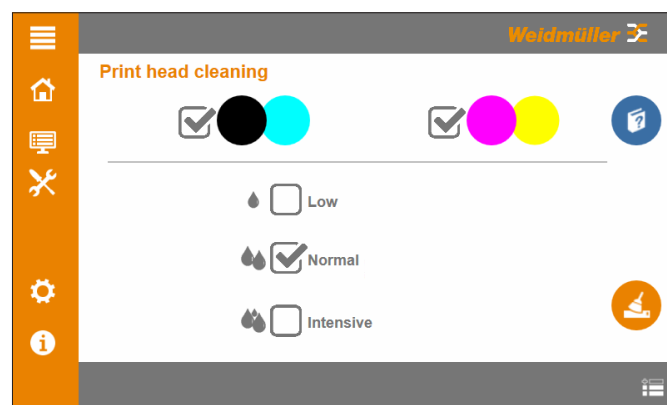

Figure 6.6 Submenu Print head cleaning

- ▶ Execute automatic print head cleaning if the nozzle check has shown insufficient print quality.
- ▶ Select the nozzles for print head cleaning.
- ▶ Select the level of intensity for cleaning.

Clean the print heads manually if automatic print head cleaning does not improve the print image (see chapter 6.3 on page 42).

### 6.3 Manual print head cleaning

Manual print head cleaning can be used to remove hardened ink residues that have not come off the nozzle plate during automated print head cleaning.

► Wait until the printer has stopped.

- ➔ Two cleaning cloths are included in the spare parts set (article no. 2449710000) for cleaning the two print heads.
- Use a separate / new cleaning cloth for each print head.



Figure 6.7 Opening the side flap

- Press the releasing device (2) to the left.
- Remove the side flap (1).

The print head moves to the maintenance position.

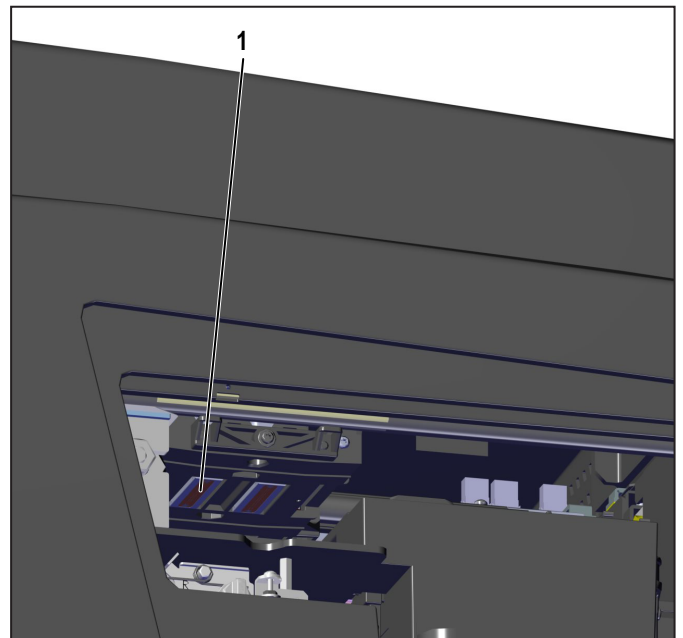

Figure 6.8 Print head 1

- Wipe the first print head (1) with a cleaning cloth.

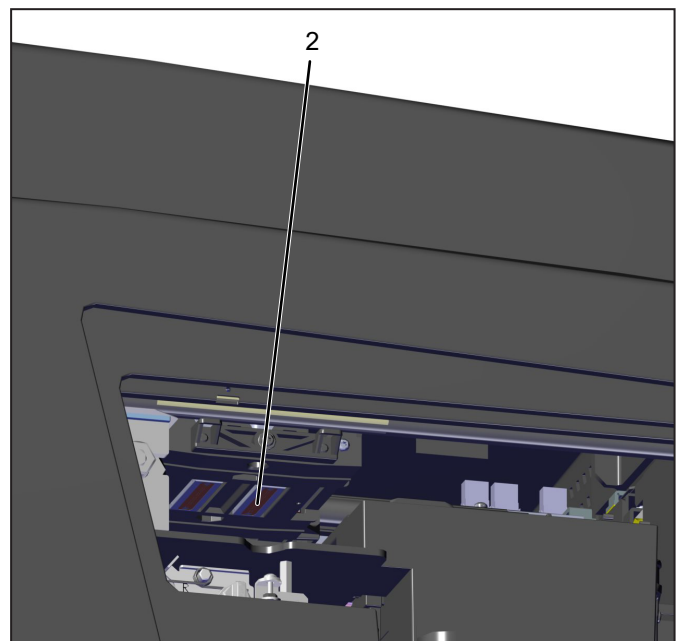





Figure 6.9 Print head 2

- Wipe the second print head (2) with a second cleaning cloth.
- Close the side flap.

## 6.4 Replacing ink cartridges and fluid cartridges

<b>CAUTION</b>	
  	<p><b>Danger to health from ink and fluid!</b></p> <ul style="list-style-type: none"> <li>▶ Wear protective gloves when replacing the ink and fluid cartridges.</li> <li>▶ After skin contact, clean the affected areas thoroughly with soap and water.</li> <li>▶ If ink or fluid has entered the eyes, immediately rinse your eyes thoroughly with plenty of water.</li> <li>▶ If you have swallowed ink or fluid, immediately rinse out your mouth, drink plenty of water, do not induce vomiting.</li> <li>▶ Keep the ink and fluid cartridges out of reach of children.</li> </ul>

<b>ATTENTION</b>
<p><b>Damage to property!</b></p> <p>Using expired ink reduces the print quality and may cause damage to the printer.</p>

 Do not replace the ink cartridges until all current print jobs have been completed.

- ▶ Replace the ink cartridges when they are empty or their expiration date has been reached.

In both cases, a message is displayed on the touch panel. The use-by date is printed on the packaging and on the label.

- ▶ Observe the following information:
  - Never touch the ink supply outlet of the ink cartridge or the area around it.
  - The ink cartridges must not be shaken, disassembled or refilled.
  - Store unopened ink cartridges in a cool and dry location (recommended 4°C). Before use, the ink cartridges should be warmed to room temperature for at least three hours.
  - Install ink cartridges in the printer immediately after removing them from the packaging.
  - When switching from downtime mode to print mode, the reliability check performed then consumes 7% of the ink. The ink fill level can be read on the touch panel.



If you open the ink tank lid, the printer stops.

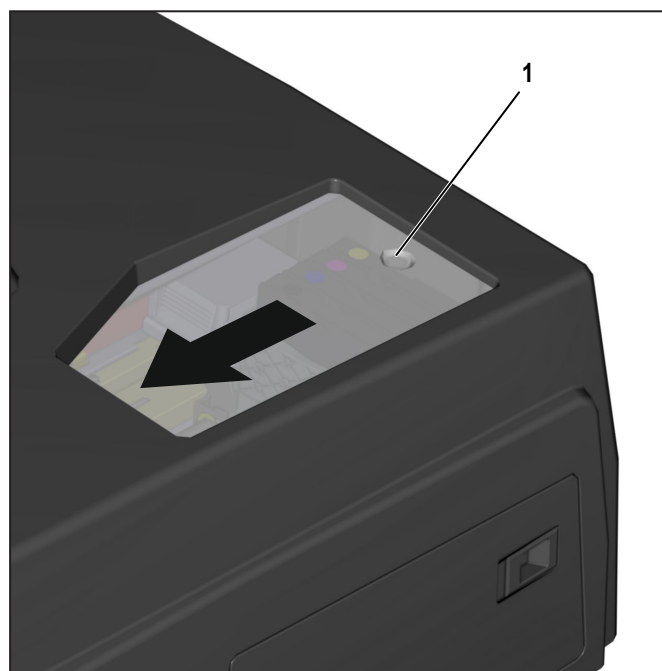

Figure 6.10 Opening the inspection flap

- ▶ Push the ink tank lid (1) in the direction of the arrow.

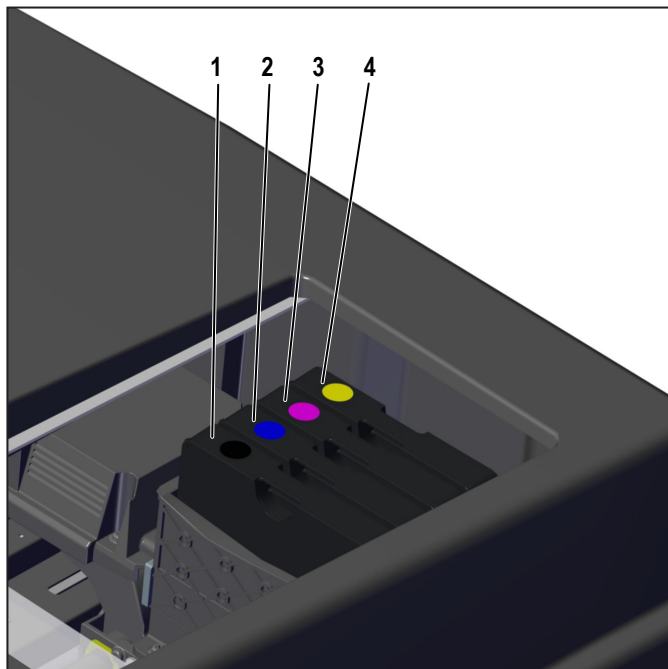

Figure 6.11 Positions of the ink cartridges

- 1 Black ink cartridge
- 2 Cyan ink cartridge
- 3 Magenta ink cartridge
- 4 Yellow ink cartridge

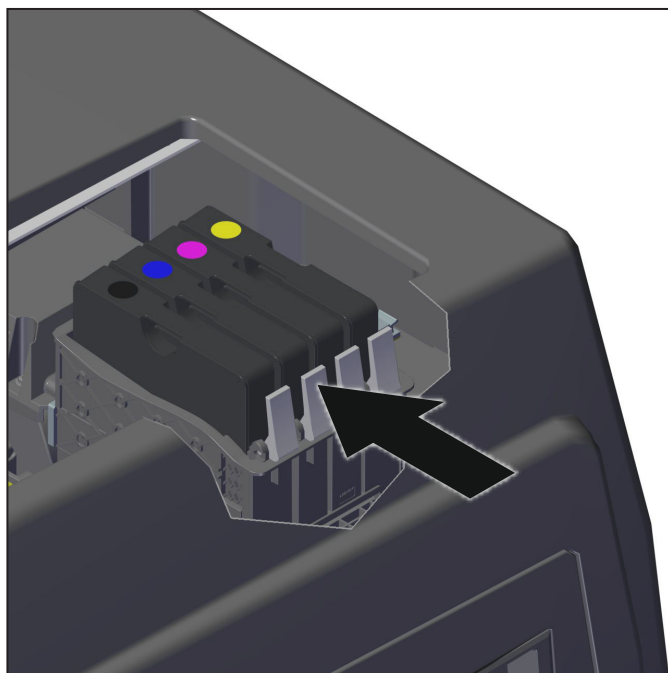

Figure 6.12 Unlocking the ink cartridge

► Unlock the ink cartridges by pressing the lug in the direction of the arrow.

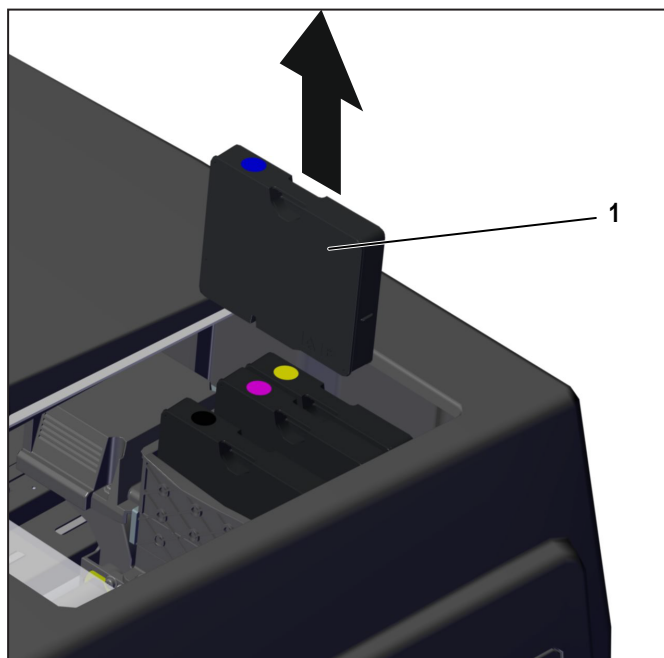

Figure 6.13 Removing the ink cartridge

► Extract the ink cartridge (1) from the top.  
► Pack the ink cartridges in their original packaging ensuring that no ink residue can leak.



You can send the ink cartridges to your Weidmüller sales agent.

### Information on inserting ink cartridges

The ink cartridges are electronically and mechanically coded, ensuring they can only be inserted correctly.

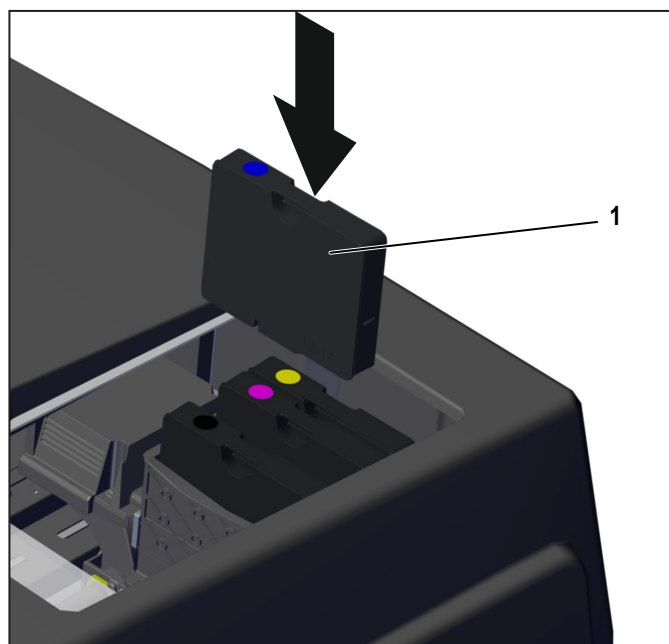

Figure 6.14 Inserting an ink cartridge

- Push the ink cartridge (1) into the defined position until it clicks into place (see chapter 4 on page 22).

The fluid cartridges are replaced in the same way as the ink cartridges. The fluid cartridges have a shelf life of two years.



You can send the fluid cartridges to your Weidmüller sales agent.

## 6.5 Calibration of the print heads

To optimize print results, the print heads can be re-calibrated. The calibration of the print heads is performed at the touch panel in the submenu **Advanced settings**.

### 6.5.1 Preparatory measures

#### Before the calibration

Before you perform the calibration, make sure of the following:

- At least software version 1.2.0 must be installed on **PrintJet CONNECT**. You can find information about the installed software version in the submenu **Version number**. If necessary, update the software (see chapter 6.8 on page 51).
- Before calibrating the print heads, perform a nozzle test (see chapter 6.2.1 on page 40).
- There must be **no** old print jobs in the printer.
- For the calibration, use two MultiCards of type: CC 30/60 MC NE WS (article no. 1934420000).

#### During the calibration

Make sure that **no** print jobs are sent to the printer during the calibration.

### 6.5.2 Calibrating print heads

In the menu **Calibration** of the submenu **Advanced settings**, you can perform the calibration of the print heads.

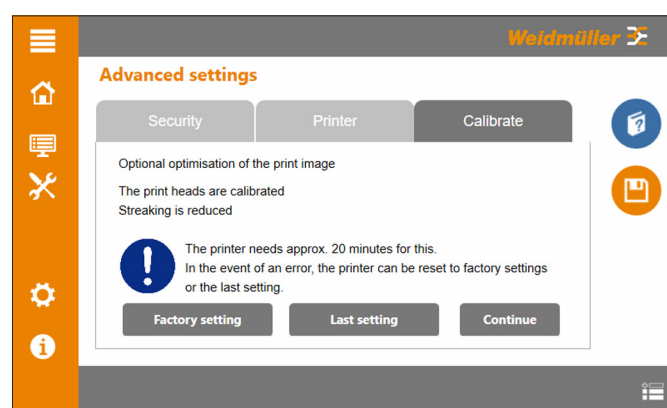

Figure 6.15 Menu Calibration

- Tap **Continue**.



Calibration of the print heads takes place in two phases:

- In the first phase, the printed elements are aligned on the MultiCard for the print resolutions 300 dpi, 600 dpi and 1200 dpi.
- In the second phase, the setting for optimizing homogeneous color areas is carried out for the print resolutions 600 dpi and 1200 dpi.

► For the first phase of the calibration, insert the first MultiCard into the input magazine.

► Tap **Print**.

The printer prints the first MultiCard.

► Tap **Continue**.

### Evaluation of the first print image



If necessary, use a magnifying glass to evaluate the result.

Example of a print image

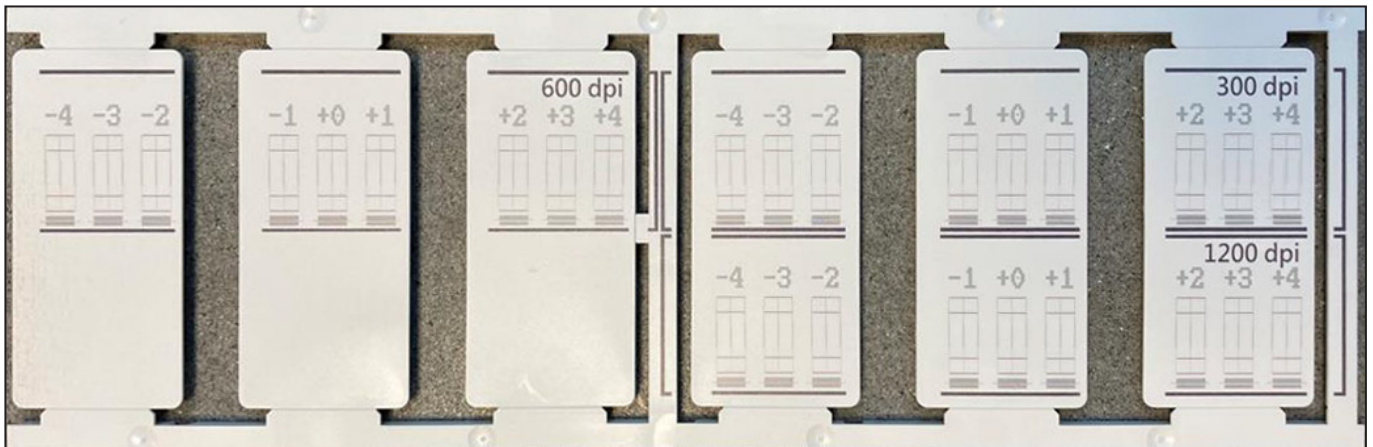

Figure 6.16 Print image 300 dpi, 600 dpi, 1200 dpi

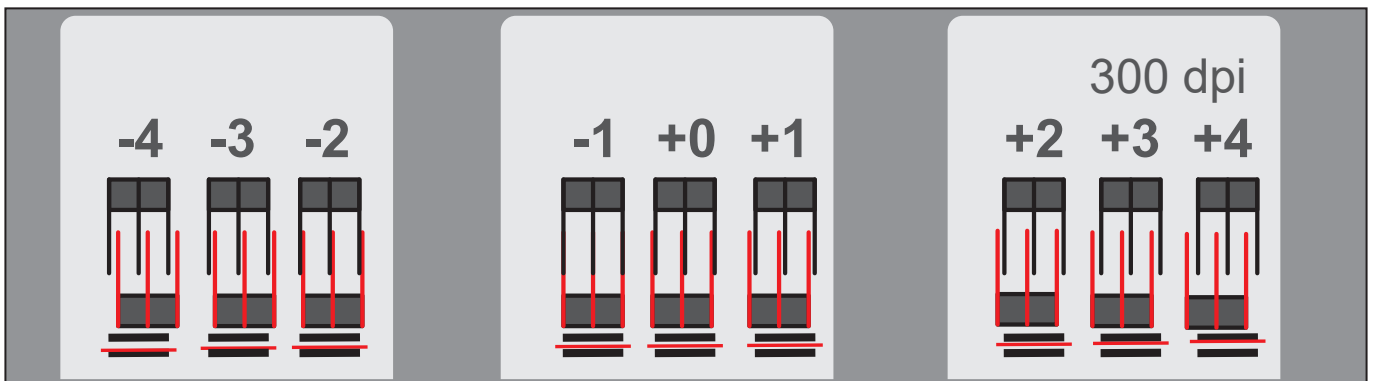

Figure 6.17 Print image 300 dpi (schematic illustration)

Orientation	not optimal	optimal
horizontal (x axis)		
vertical (y axis)		

The current output value is always **+0**.

In this example (resolution 300 dpi), however, the horizontal and vertical alignment is **not** optimal. Correct the values within the range **-4** and **+4**. For horizontal alignment, the value **-1** is the optimal value. For vertical alignment, the value **+1** is the optimal value.

- ▶ For horizontal correction, tap the horizontal alignment symbol in the column **-1**.

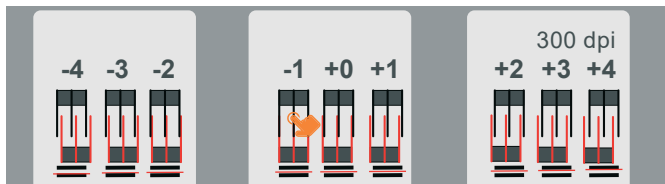

The symbol for the correction value **-1** is marked.

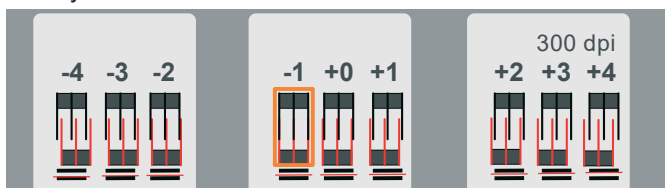

- ▶ For vertical correction, tap the vertical alignment symbol in the column **+1**.

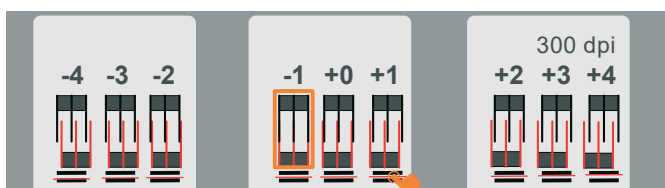

The symbol for the correction value **+1** is marked.

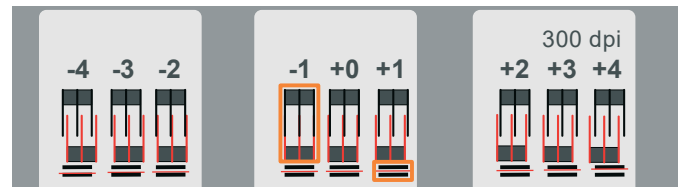

- ▶ Tap **Continue**.
  - ▶ Repeat the correction steps for the resolutions 600 dpi and 1200 dpi.
  - ▶ Save the settings after making the corrections for all resolutions.
  - ▶ For the second phase of the calibration, insert the second MultiCard into the input magazine.
  - ▶ Tap **Print**.
- The printer prints the second MultiCard.
- ▶ Tap **Continue**.

### Evaluation of the second print image



If necessary, use a magnifying glass to evaluate the result.

### Example of a print image

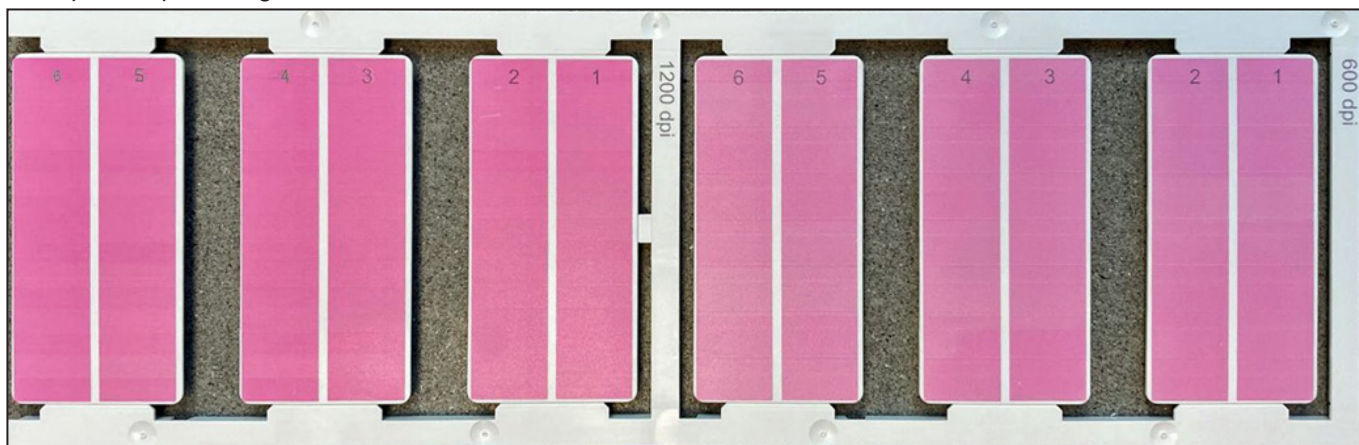

Figure 6.18 Print image 600 dpi, 1200 dpi

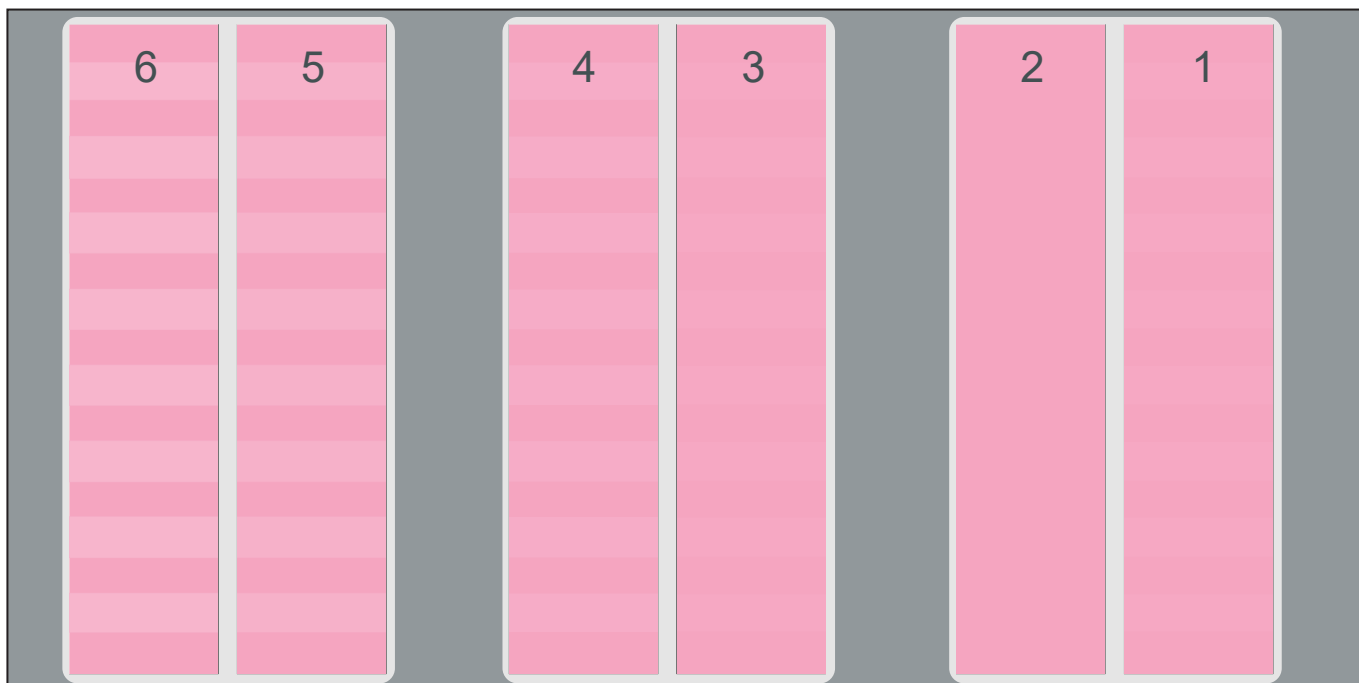
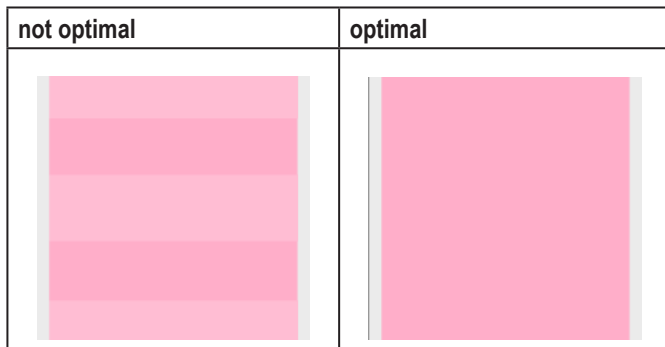

Figure 6.19 Print image 600 dpi (schematic illustration)



In this example (resolution 600 dpi), the color field **2** represents the optimal homogeneous color area.

- ▶ Tap **Continue**.
- ▶ Select the respective number in the drop-down list for resolution 600 dpi (in this example: number **2**).
- ▶ Evaluate the print image for resolution 1200 dpi.
- ▶ Select the respective number in the drop-down list for resolution 1200 dpi.
- ▶ Save the settings.

The calibration of the print heads has been completed. After the calibration, you are back in the main menu **System status**.

### 6.5.3 Resetting the calibration

- ▶ Open the menu **Calibration** of the submenu **Advanced settings**.

To reset to the last setting:

- ▶ Tap **Last setting**.

The last settings of the calibration are accepted.

To reset to the factory setting:

- ▶ Tap **Factory setting**.

The factory setting of the calibration is accepted.

## 6.6 Replacing the ink collector



Do not replace the ink collector until all current print jobs have been completed and a message requesting replacement appears on the touch panel.

The ink collector must be replaced completely. It must not be opened.



When you open the side flap, the printer stops.

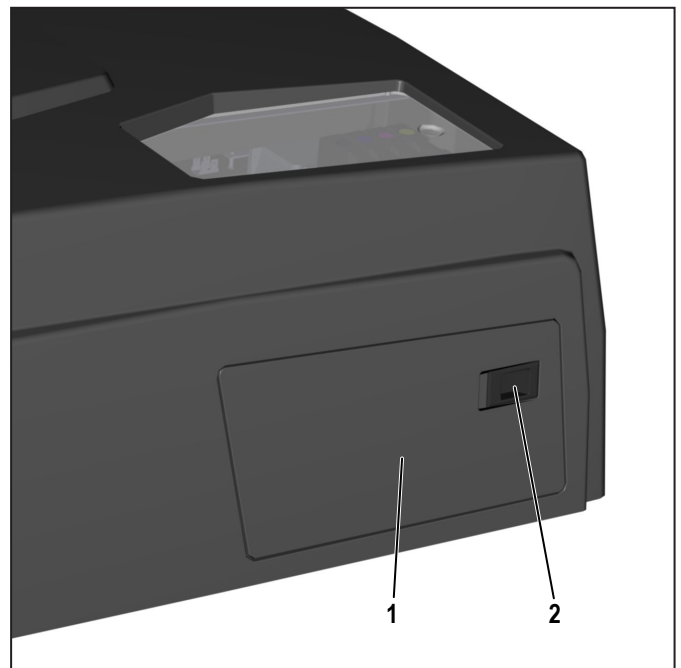

Figure 6.20 Opening the side flap

- ▶ Press the releasing device (2) to the left.
- ▶ Remove the side flap (1).

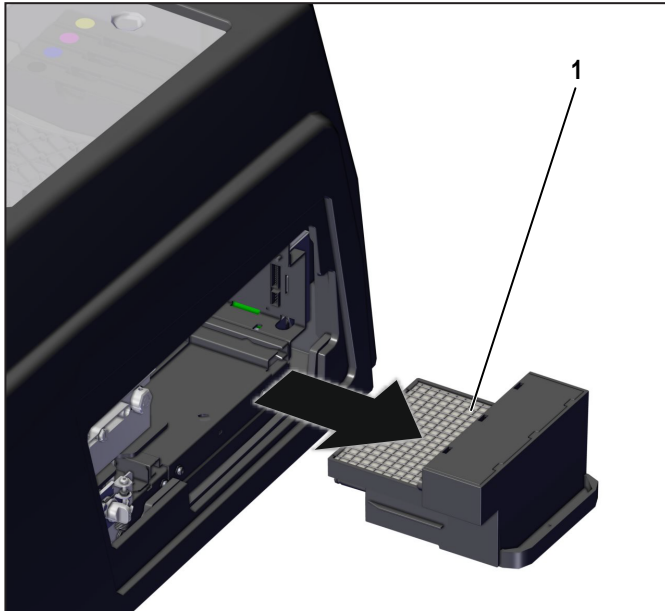

Figure 6.21 Extracting the ink collector

- ▶ Lift the ink collector slightly to overcome the resistance of the flat locking pin and extract the ink collector (1) in the direction of the arrow.



You can send the ink collector to your Weidmüller sales agent. To do so, pack the ink collector in the packaging of the service set (PJC CON WASTE PAD 2715660000)

The new ink collector is equipped with a ventilation safety device (seal). To ventilate the fluid tank during operation, the seal must be removed before inserting the ink collector.

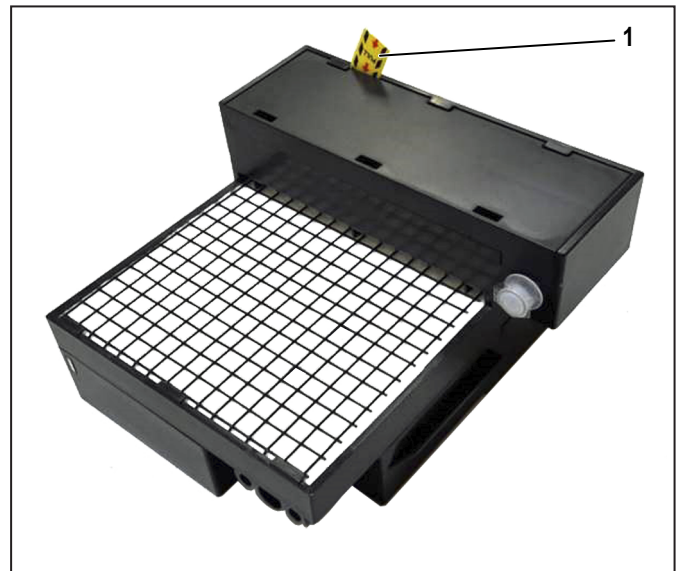

Figure 6.22 Ink collector with seal

- ▶ Remove the seal (1) from the ink collector.

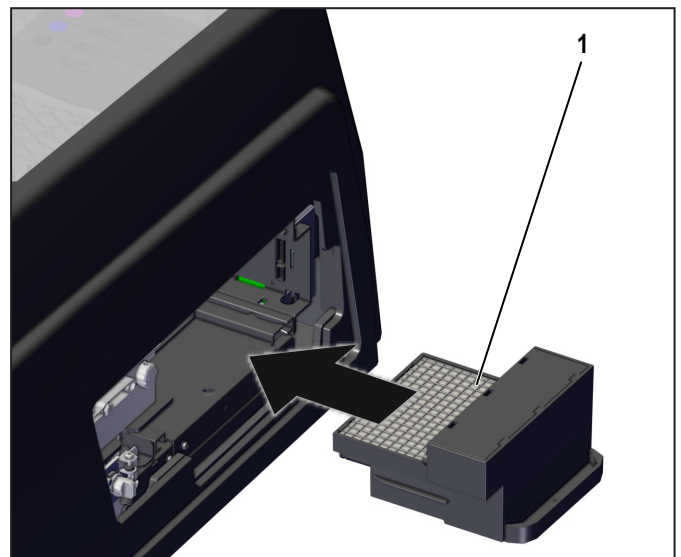



Figure 6.23 Inserting the ink collector

- ▶ Insert the new ink collector (1) into the printer in the direction of the arrow until the ink collector clicks into place.
- ▶ Close the side flap.

## 6.7 Cleaning the printer enclosure / touch panel

	DANGER
	<p><b>Warning of electric shock!</b></p> <ul style="list-style-type: none"> <li>▶ Clean the printer enclosure only from the outside.</li> <li>▶ Ensure that no moisture enters the printer.</li> <li>▶ Ensure that no moisture reaches live parts.</li> </ul>

ATTENTION
<p><b>Damage to property!</b></p> <p>The use of volatile cleaning agents can lead to color changes and cracks in the printer enclosure.</p> <ul style="list-style-type: none"> <li>▶ Do not use volatile chemicals such as benzene or thinner.</li> </ul>

- ▶ Clean the printer enclosure regularly with a soft, dry or slightly moistened cloth.
- ▶ In case of heavy soiling, initially wipe the printer enclosure with a cloth moistened with a neutral cleaning agent, then with a slightly moistened cloth, and finally with a dry cloth.
- ▶ Clean the touch panel regularly with a cleaning agent suitable for touch screens and a soft, lint-free cloth.

## 6.8 Updating the printer software



Have the printer firmware updated by skilled personnel.

You can find information about the marking software (operation and update) in the user manual for M-Print® PRO.

### 6.8.1 Updating with M-Print® PRO

#### Updating from the local directory



During the update process of M-Print® PRO, current update files for all supported printer models are saved in the corresponding directories.

Example for printer module **PrintJet CONNECT**: Save the update file `Update.bin` in the directory `PrintJetCONNECT_UPDATE_V#_#_#_BIN`. (The character string "V#\_#\_#" in the file name describes the current version number, e.g. "V1\_2\_1")

Before the update process, make sure that the printer has been added to M-Print® PRO and the printer has been started.

- ▶ Start M-Print® PRO.
- ▶ In the menu **Tools > Options > PrintJet CONNECT**, select the entry **Administration**.
- ▶ Next to the entry **Select Printer:**, select the printer (name or IP address of the printer).
- ▶ Next to the entry **Update File:**, navigate to the preset directory of the update file.
- ▶ Open the update file `Update.bin`.
- ▶ Click **Start printer update**.
- ▶ Follow the further instructions of M-Print® PRO.

Once the update has been completed, a message appears on the touch panel of the printer.

- ▶ Confirm the message with **OK**.

### Updating from the update server

- ▶ Start M-Print® PRO.
- ▶ In the menu **Help**, select the entry **Check for updates...**
- ▶ Confirm the following safety prompt with **Yes**.

The search for updates on the update server is started.

- ▶ Mark the component you wish to update.
- ▶ Tap **Perform update...**
- ▶ Follow the instructions on the screen.

### 6.8.2 Updating with PJC Update Helper

The file `PJC_Update_Helper.exe` contains the current firmware and installs the firmware on the printer.

- ▶ Download the file from the website [www.weidmueller.com](http://www.weidmueller.com).
- ▶ To do so, navigate to the following storage location on the website:

Products > Software > M-Print® PRO > MORE INFORMATION > Downloads > Printer Firmware > PrintJet CONNECT Firmware

- ▶ Run the file and follow the instructions of the program.

# 7 Troubleshooting

## 7.1 General information

The following measures are helpful to avoid faults:

- Ensure that the printer is installed on a flat even surface.
- Ensure that the printer is not exposed to vibrations.
- Ensure that the MultiCards/MetalliCards are aligned correctly.
- Only use original Weidmüller ink cartridges.
- When not in use, put the printer in standby or downtime mode.
- Never remove the printer enclosure.



If you open the ink tank lid, the printer stops. The print head moves to the starting position above the cleaning unit and stops there. When you close the ink tank lid again, the printer continues where it stopped. No information is lost and nothing needs to be restarted.

- ▶ If a MultiCard/MetalliCard remains in the device, turn the device off and on again.

The MultiCard/MetalliCard is conveyed out of the device.

### Messages on the touch panel

A fault at the printer or necessary operator intervention is indicated by a message on the touch panel.

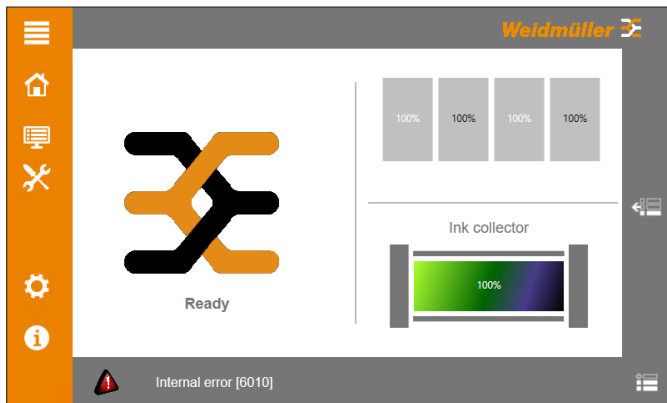

Figure 7.1 Error message in the footer (example)

- ▶ Tap the error message.

A window opens showing the complete error message.

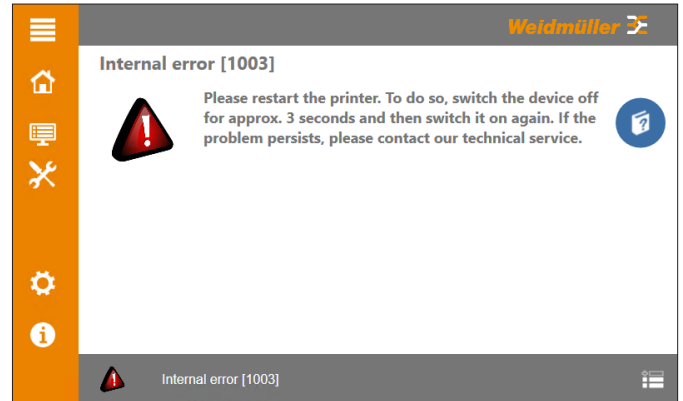

Figure 7.2 Information and measures (example)

- ▶ Tap **Show online help** to get more information about the fault.
- ▶ Contact Weidmüller Service if a fault cannot be rectified.
- ▶ Tap **Close online help** to hide the window.

## 7.2 Trouble list

Fault/Code	Reason	Measure
The printer cannot be connected via USB cable.	The USB cable is defective.	Replace the defective USB cable with an intact USB cable.
	An incorrect USB port was selected.	Select a different USB port (see chapter 5.6.8 on page 37).
The printer cannot be connected via Ethernet.	The network cable is defective.	Replace the defective network cable with an intact network cable.
	The IP address of the printer is incorrect.	Check if the IP address of the printer was obtained correctly. In this case, reassign the IP address of the printer (see chapter 5.6.6 on page 36).
	The printer and the PC on which M-Print® PRO is installed are not in the same network.	Ensure that the printer and the PC are in the same network. Contact your administrator for this purpose.
The printer cannot be connected via WiFi.	The entered password is incorrect.	Enter the correct password.
	The IP address of the printer is incorrect.	Check if the IP address of the printer was obtained correctly. In this case, reassign the IP address of the printer (see chapter 5.6.7 on page 37).
	The printer and the PC on which M-Print® PRO is installed are not in the same network.	Ensure that the printer and the PC are in the same network. Contact your administrator for this purpose.
The print image is poor.	The print head nozzles are clogged.	Execute a nozzle check (see chapter 6.2.1 on page 40). Depending on the nozzle check result: Execute automatic or manual print head cleaning.  Automatic print head cleaning (see chapter 6.2.2 on page 41).  Manual print head cleaning (see chapter 6.3 on page 42).
	The alignment of the print heads is insufficient.	Perform a manual calibration of the print heads (see chapter 6.5.2 on page 45).

Fault/Code	Reason	Measure
<p>The ink has not cured sufficiently and can smear.</p>	<p>The curing performance is too weak.</p>	<p>Increase the curing performance in the M-Print® PRO marking software (see M-Print® PRO user manual).</p>
	<p>The supply voltage is too low.</p>	<p>Ensure that the value for the voltage supply is at least 210 V. The value for the voltage supply can be seen in the submenu <b>System Information</b> (see chapter 5.6.13 on page 39).</p>
<p>The printed markers display bubbles after printing.</p>	<p>The curing performance is too strong.</p>	<p>Reduce the curing performance in the M-Print® PRO marking software (see M-Print® PRO user manual).</p>
	<p>The supply voltage is too high.</p>	<p>Ensure that the value for the voltage supply is max. 240 V. The value for the voltage supply can be seen in the submenu <b>System Information</b> (see chapter 5.6.13 on page 39).</p>
<p>The print is not centered on each marker.</p>	<p>The adjustment function in the M-Print® PRO marking software is not enabled.</p>	<p>Enable the automatic adjustment function in the M-Print® PRO marking software (see M-Print® PRO user manual).</p>

## 8 Decommissioning the printer

### 8.1 Downtime mode

**ATTENTION**

**Damage to property!**

If the printer is not in operating mode and not in standby mode, the ink nozzles will clog.

- ▶ Switch the printer to downtime mode.

#### 8.1.1 Longer downtime

Downtime mode can be activated in the submenu **Longer downtime**. If the printer has to be disconnected from the power supply for more than three weeks, the printer must be switched to downtime mode.

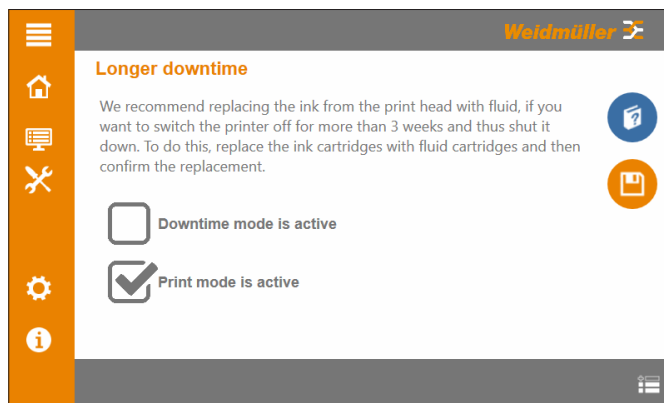

Figure 8.1 Submenu Longer downtime

- ▶ Replace the ink cartridges with fluid cartridges.
- ▶ Activate downtime mode.

In downtime mode, the fluid replaces the ink and prevents the ink lines and nozzles from drying up.

- ▶ Wait until the rinsing process has been finished.
- ▶ Turn off the printer with the standby button on the touch panel (see chapter 4.7 on page 26).
- ▶ Turn off the printer at the main switch on the rear of the device (see chapter 3.1.2 on page 14).
- ▶ Remove all MultiCards and MetalliCards from the input magazine and the output magazine.
- ▶ Fold the lifting element upwards.
- ▶ Insert the output magazine.
- ▶ Disconnect all cables from the printer.
- ▶ Secure the ink tank lid with adhesive tape.

After longer downtime:

- ▶ Restore the operational readiness of the printer.
- ▶ Replace the fluid cartridges with ink cartridges.
- ▶ Activate print mode.

### 8.2 Packing and transporting the printer

**ATTENTION**

Due to its weight, the printer must always be transported (carried) by two people.

- ▶ Always hold the printer at the front and rear when transporting it.

- ▶ Only use the original packaging when transporting the printer.
- ▶ If you no longer have the original packaging, request a packaging set from Weidmüller Interface GmbH & Co. KG.

### 8.3 Disposing of the printer

- ▶ Send the printer to your Weidmüller sales agent. Weidmüller will then recycle and dispose of your printer properly in accordance with current laws and regulations. Weidmüller assumes the costs incurred.

#### Disposing of batteries



A CR 2032 lithium battery (3 V) is installed in the printer.

Used batteries do not belong in household waste. Batteries must be disposed of properly. Please observe the country-specific regulations for the disposal of batteries. Please contact your local waste management company or municipal administration for more information.

In connection with the sale of batteries or with the delivery of devices that contain batteries, we are obliged to inform you of the following: As the end user, you are legally obliged to return used batteries.

## 9 Annex

### 9.1 Technical data

Technical data									
Print material	Weidmüller print material: MultiCards and MetalliCards								
Technology	Ink-jet process with heat curing								
Print quality	4 levels (Speed Print, Quality Print Text, Quality Print Graphic, Premium Print)								
Marking software	M-Print® PRO								
System requirements	Microsoft Windows® 8, 8.1, 10, 11								
Feed	Magazine for max. 50 MultiCards (for MultiCards only) Single feed for MetalliCards and MultiCards								
Print speed	Up to 3 MultiCards per minute, depending on the selected parameters								
Interfaces	USB 2.0 and network 10 Base-T / 100 Base-TX, WiFi dual band								
Voltage supply	AC 115/230 V, 8 A, 50/60 Hz								
Fuse	10 ATH 250 VAC								
Operating location	Office conditions								
Ambient temperature	18°C – 30°C 65°F – 86°F								
Relative air humidity	10% - 80%								
Dimensions (L x W x H)	<table border="0"> <tr> <td>Length, including output magazine:</td> <td>1133 mm</td> </tr> <tr> <td>Length, excluding output magazine:</td> <td>930 mm</td> </tr> <tr> <td>Width:</td> <td>590 mm</td> </tr> <tr> <td>Height, including touch panel:</td> <td>454 mm</td> </tr> </table>	Length, including output magazine:	1133 mm	Length, excluding output magazine:	930 mm	Width:	590 mm	Height, including touch panel:	454 mm
Length, including output magazine:	1133 mm								
Length, excluding output magazine:	930 mm								
Width:	590 mm								
Height, including touch panel:	454 mm								
Weight	63 kg (138.60 lbs) with packaging 38 kg (83.60 lbs) without packaging								
Ink system	Color cartridges, 1 x black, 1 x cyan, 1 x magenta, 1 x yellow								

## 9.2 Ordering data

Product / Spare part	Designation and order no.
Ink-jet printer	Print <b>Jet CONNECT</b> 2715590000
Ink cartridge set	PJ CON INK SET 2715600000
Cyan ink cartridge	PJ CON INK C 2715610000
Magenta ink cartridge	PJ CON INK M 2715620000
Yellow ink cartridge	PJ CON INK Y 2715630000
Black ink cartridge	PJ CON INK K 2715640000
Fluid cartridge set	PJ CON FLUID SET 2715650000
Ink collector	PJ CON WASTE PAD 2715660000
Dust cover	PJ ADV TEXTILE COVER 2592960000
Service flap	PJ CON SERVICE FLAP 2715690000
Cleaning unit	PJ CON CLEANING UNIT 2715700000
User manual	<p>The user manual can be downloaded from the Internet:  <a href="https://eshop.weidmueller.com">https://eshop.weidmueller.com</a></p> <p>To do so, enter the article number 2715590000 in the search bar of the online shop. Under the menu item "Software support", you will find download links to current documents and product downloads.</p>

## 9.3 Declaration of Conformity

PrintJet CONNECT complies with the relevant basic health and safety requirements of EU directives:

2014/35/EU Low Voltage Directive  
 2014/30/EU EMC Directive  
 2011/65/EU RoHS

The Declaration of Conformity can be found in the online shop at <https://eshop.weidmueller.com>

To do so, enter the article number 2715590000 in the search bar of the online shop. Under the menu item "Software support", you will find download links to current documents and product downloads.