

Lightning and surge protection

Protect energy systems and installations sustainably
VARITECTOR PU PV for more safety



Weidmüller 



Protect your energy generation against surge and overvoltage

Reliable protection technology maximizes system availability

Photovoltaic energy generation is one of the fastest-growing green energy sources. Hundreds of MW of rooftop systems and utility-scale PV parks are installed every year. Best system availability and minimised OPEX (operational expenses) define the profitability of any size of system.

PV systems are directly exposed to environmental conditions due to the fact that they are always installed in extraordinary locations. Thus, the probability of being impacted by lightning is high. Unprotected PV systems suffer repeated and significant damage to their components. This results in substantial repair and replacement costs, system downtime and loss of revenue. Automation systems, monitoring components and PV inverters must be protected reliably and in line with current standards. IEC and UL standards define precisely the rules to be applied for implementing state-of-the-art PV installations.



Visit our website for more information
www.weidmueller.com/varitector_pv_solutions

VARIRECTOR surge protection for all kind of photovoltaic systems

Lean design and latest technology guarantee best plant protection

Modern photovoltaic energy generation is streamlined to efficiency. Reliable surge protection with future-proof performance is a must to maximise system uptime and profitability. The VARIRECTOR PU PV series is designed for use in PV string combiner boxes for generator voltages up to 1,500 V and complies with latest UL and EN standards for global application.

600 V
1,000 V
1,500 V

Type I and II protection

Type I and II protection is supported for 600V, 1,000V and 1,500V systems fully compliant to latest EN / IEC standards.

I_{scpv}
11 kA

Maximum short-circuit capability

PV plants, which combine many panels in a string, are efficiently protected up to 11 kA of the prospective short-circuit current. Additional fuses for the SPD are not required.

Pluggable inserts



Pluggable arresters

The surge protection devices are easily pluggable and enable a tool-free, fast and cost-effective replacement.

up to
4,000 m

Safe operation up to 4,000 m

PV plants, also such located in high altitude regions, are reliably protected. An additional risk analysis of deratings is not required for extraordinary locations.



Customise your protection with VARIRECTOR PU devices

A full scale portfolio for tailored DC and AC protection solutions

Several aspects need to be covered that are related to the type of system (e.g. rooftop systems or utility-scale open space systems). When selecting overvoltage protection measures, a set of regulations have to be observed.

PV systems with external lightning protection

Type II surge protection can be used, provided the separation distance is maintained (usually > 0.7 m to 1 m). If the separation distance is not maintained, a surge protection Type I for DC cabling is required.

PV systems without external lightning protection

This is a common design for which surge protection Type II must be provided for DC cabling.

The figure on the right shows the general architecture of a PV system. The table below is intended to help you select the correct surge protection products according to the specifications of applicable standards in a PV system.

1 In the main distribution, 2 on or in the inverter (AC side), 3 on or in the inverter (DC side), 4 on the generator field.

L_1 describes the cable length between the main distribution board and PV inverter (AC side) and L_2 describes the line length between PV inverter and PV generator (DC side). With a line length > 10 m, an SPD is required on both sides by the standard.

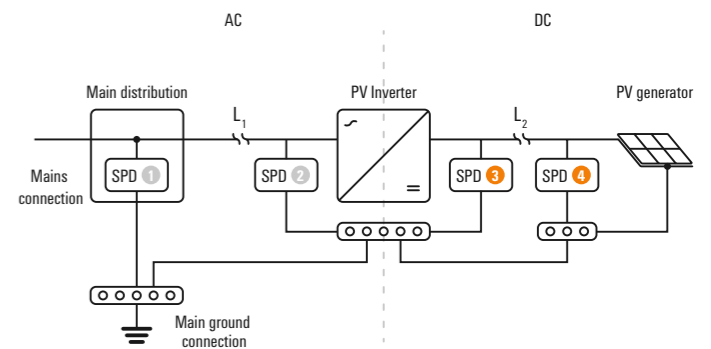

Question 1: Outdoor lightning protection system present?	Question 2: Separation distance observed?	Question 3: Line length L_1 less than 10 m?	Question 4: Line length L_2 less than 10 m?	Installation locations (AC)		Installation locations (DC)	
				SPD 1	SPD 2	SPD 3	SPD 4
no	-	no	no	Type II AC	Type II AC	Type II PV	Type II PV
no	-	no	yes	Type II AC	Type II AC	Type II PV	-
no	-	yes	no	Type II AC	-	Type II PV	Type II PV
no	-	yes	yes	Type II AC	-	Type II PV	-
yes	yes	no	no	Type I AC	Type II AC	Type II PV	Type II PV
yes	yes	no	yes	Type I AC	Type II AC	Type II PV	-
yes	yes	yes	no	Type I AC	-	Type II PV	Type II PV
yes	yes	yes	yes	Type I AC	-	Type II PV	-
yes	no	no	no	Type I AC	Type I AC	Type I PV	Type I PV
yes	no	no	yes	Type I AC	Type I AC	Type I PV	-
yes	no	yes	no	Type I AC	-	Type I PV	Type I PV
yes	no	yes	yes	Type I AC	-	Type I PV	-

*If the inverter and the main distribution board are connected to the same earthing bar with a cable length of less than or equal to 0.5 m each, no SPD is required at installation location "2".

Choose the right one!

VARITECTOR PU PV

AC protection for 230 V grids ^{1 2}

Description	Type	Version	Max. continuous voltage U _c	Discharge current I _{imp} /I _{max}	Order No.
VPU AC I 3+1 275V/25 LCF S 2PE	I + II	Without remote contact	275 V	25 kA/65 kA	2726760000
VPU AC I 3+1 R 275V/25 LCF S 2PE	I + II	With remote contact	275 V	25 kA/65 kA	2726770000
VPU AC I 0 275V/25 LCF 2PE	I + II	Spare arrester	275 V	25 kA/65 kA	2730840000
VPU AC I 3+1 300/12.5 LH	I + II	Without remote contact	300 V	12,5 kA/50 kA	2983580000
VPU AC I 3+1 R 300/12.5 LH	I + II	With remote contact	300 V	12,5 kA/50 kA	2983590000
VPU AC I 0 300/12.5 LH	I + II	Spare arrester	300 V	12,5 kA/50 kA	2983620000
VPU AC I 3+MOV R 950/12.5	I + II	With remote contact	950 V	12,5 kA/50 kA	2845570000
VPU AC I 0 950/12.5	I + II	Spare arrester	950 V	12,5 kA/50 kA	2855240000
VPU AC I 0 MOV 950/12.5	I + II	Spare arrester	950 V	12,5 kA/50 kA	2855250000
VPU AC II 3+1 300/50	II + III	Without remote contact	300 V	- /50 kA	2591080000
VPU AC II 3+1 R 300/50	II + III	With remote contact	300 V	- /50 kA	2591090000
VPU AC II 0 300/50	II + III	Spare arrester	300 V	- /50 kA	2591010000



DC protection in 600 V applications ^{3 4}

Description	Type	Version	Max. continuous voltage U _c	Discharge current I _{imp} /I _{max}	Order No.
VPU PV I+II 3 600 E	I + II	Without remote contact	600 V	6,25 kA/40 kA	2857030000
VPU PV I+II 3 R 600 E	I + II	With remote contact	600 V	6,25 kA/40 kA	2857040000
VPU PV I+II 0 600 E	I + II	Spare arrester	600 V	6,25 kA/40 kA	2857050000
VPU PV II 3 600	II	Without remote contact	600 V	- /50 kA	2857060000
VPU PV II 3 R 600	II	With remote contact	600 V	- /50 kA	2857070000
VPU PV II 0 600	II	Spare arrester	600 V	- /50 kA	2857080000
VPU PV II 3 600 MB (Monobloc)	II	Without remote contact	600 V	- /40 kA	3034780000
VPU PV II 3 R 600 MB (Monobloc)	II	With remote contact	600 V	- /40 kA	3034790000



DC protection in 1,000 V applications ^{3 4}

Description	Type	Version	Max. continuous voltage U _c	Discharge current I _{imp} /I _{max}	Order No.
VPU PV I+II 3 1000	I + II	Without remote contact	1100 V	6,25 kA/40 kA	2530610000
VPU PV I+II 3 R 1000	I + II	With remote contact	1100 V	6,25 kA/40 kA	2530620000
VPU PV I+II 0 1000	I + II	Spare arrester	1100 V	6,25 kA/40 kA	2530600000
VPU PV I+II 0M 1000	I + II	Spare arrester	1100 V	6,25 kA/40 kA	2534300000
VPU PV II 3 1000	II	Without remote contact	1100 V	- /40 kA	2530550000
VPU PV II 3 R 1000	II	With remote contact	1100 V	- /40 kA	2530180000
VPU PV II 0 1000	II	Spare arrester	1100 V	- /40 kA	2530660000
VPU PV II 3 1000 MB (Monobloc)	II	Without remote contact	1.000 V	- /40 kA	3034850000
VPU PV II 3 R 1000 MB (Monobloc)	II	With remote contact	1.000 V	- /40 kA	3035150000



Recommendation

Since PV systems are usually installed in unprotected environments (danger from direct lightning strikes) it is always advisable to install type I+II surge protection. This increases also the service life of the protective components used.

DC protection in 1,000 V applications 5-pole ^{3 4}

Description	Type	Version	Max. continuous voltage U _c	Discharge current I _{imp} /I _{max}	Order No.
VPU PV I+II 5 1000	I + II	Without remote contact	1100 V	5kA/40 kA	2856440000
VPU PV I+II 5 R 1000	I + II	With remote contact	1100 V	5kA/40 kA	2856490000
VPU PV I+II 5 0M 1000	I + II	Spare arrester	1100 V	5kA/40 kA	2856650000
VPU PV I+II 5 0 1000	I + II	Spare arrester	1100 V	5kA/40 kA	2857000000
VPU PV II 5 1000	II	Without remote contact	1100 V	- /40 kA	2856500000
VPU PV II 5 R 1000	II	With remote contact	1100 V	- /40 kA	2857020000
VPU PV II 5 0 1000	II	Spare arrester	1100 V	- /40 kA	2857010000



DC protection in 1,500 V applications ^{3 4}

Description	Type	Version	Max. continuous voltage U _c	Discharge current I _{imp} /I _{max}	Order No.
VPU PV I+II 3 1500	I + II	Without remote contact	1500 V	5 kA /30 kA	2530580000
VPU PV I+II 3 R 1500	I + II	With remote contact	1500 V	5 kA /30 kA	2530590000
VPU PV I+II 0 1500	I + II	Spare arrester	1500 V	5 kA /30 kA	2530570000
VPU PV I+II 0M 1500	I + II	Spare arrester	1500 V	5 kA /30 kA	2534330000
VPU PV II 3 1500	II	Without remote contact	1500 V	- /30 kA	2530640000
VPU PV II 3 R 1500	II	With remote contact	1500 V	- /30 kA	2530650000
VPU PV II 0 1500	II	Spare arrester	1500 V	- /30 kA	2530630000
VPU PV II 3 1500 MB (Monobloc)	II	Without remote contact	1500 V	- /40 kA	3035160000
VPU PV II 3 R 1500 MB (Monobloc)	II	With remote contact	1500 V	- /40 kA	3035170000



DC protection in 1,500 V applications 5-pole ^{3 4}

Description	Type	Version	Max. continuous voltage U _c	Discharge current I _{imp} /I _{max} /I _{total}	Order No.
VPU PV I+II 5 1500	I + II	Without remote contact	1500 V	5kA/40 kA/10 kA	3012980000
VPU PV I+II 5 R 1500	I + II	With remote contact	1500 V	5kA/40 kA/10 kA	3012990000
VPU PV I+II 5 0 1500	I + II	Spare arrester	1500 V	5kA/40 kA/10 kA	3013020000
VPU PV I+II 5 0M 1500	I + II	Spare arrester	1500 V	5kA/40 kA/10 kA	3013010000



VPCB

Description	Type	Version	Max. continuous voltage U _c	Discharge current I _{imp} /I _{max}	Order No.
VPCB PV II R 1000	II	With remote contact	1100 V	- /40 kA	2665690000
VPCB PV I+II 1000	I + II	Without remote contact	1100 V	6,25 kA/40 kA	2665740000
VPCB PV I+II R 1000 E	I + II	With remote contact	1100 V	6,25 kA/40 kA	2665730000
VPCB PV I+II R 1000	I + II	With remote contact	1100 V	6,25 kA/40 kA	2665760000
VPCB PV I+II R M 1000	I + II	With remote contact	1100 V	6,25 kA/40 kA	2665770000
VPCB PV I+II 5 R M 1000	I + II	With remote contact	1100 V	6,25 kA/40 kA	2874710000



Visit our online catalogue for more information

Weidmüller – Your partner in Smart Industrial Connectivity

As experienced experts we support our customers and partners around the world with products, solutions and services in the industrial environment of power, signal and data. We are at home in their industries and markets and know the technological challenges of tomorrow. We are therefore continuously developing innovative, sustainable and useful solutions for their individual needs. Together we set standards in Smart Industrial Connectivity

We cannot guarantee that there are no mistakes in the publications or software provided by us to the customer for the purpose of making orders. We try our best to quickly correct errors in our printed media.

All orders are based on our general terms of delivery, which can be reviewed on the websites of our group companies where you place your order. On demand we can also send the general terms of delivery to you.

Weidmüller Interface GmbH & Co. KG
Klingenbergstraße 26
32758 Detmold, Germany
T +49 5231 14-0
F +49 5231 14-292083
www.weidmueller.com

Personal support can
be found on our website:
www.weidmueller.com/contact

Made in Germany

03/2026/TCDS