

WI-MOD-9-D

Installation Guide

WARNING !
EXPLOSION HAZARD
 DO NOT DISCONNECT WHILE
 CIRCUIT IS LIVE UNLESS
 AREA IS KNOWN TO BE NON
 HAZARDOUS

Statutory Requirements

FCC: Unlicensed operation limits the radio power. High gain aerials may only be used to compensate for cable losses.

THIS EQUIPMENT IS SUITABLE FOR USE IN CLASS 1 DIVISION 2 GROUPS ABC AND D OR NON HAZARDOUS LOCATIONS

Antenna Installation

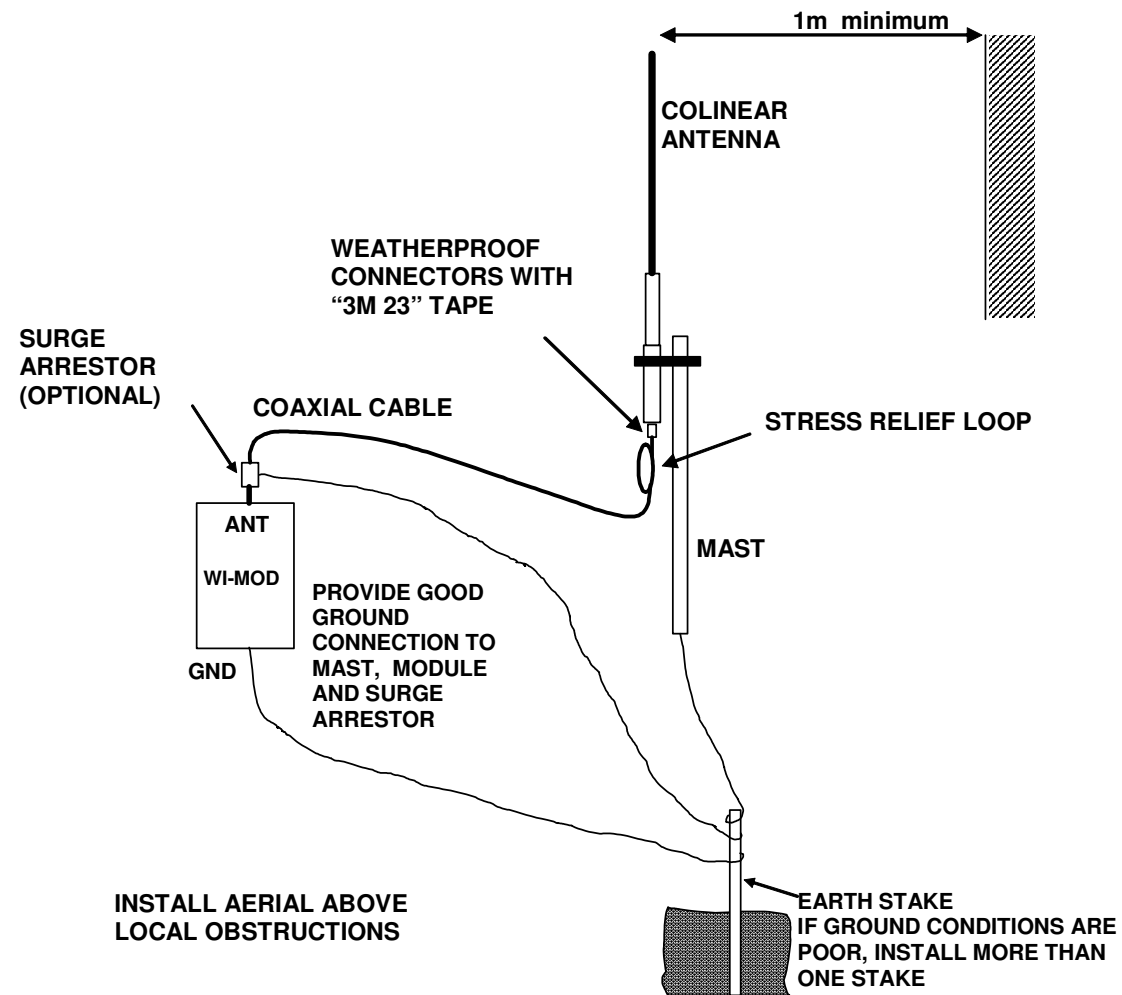

WI-MOD-9-D Wiring

Power Supply 10 – 30 VDC / 10 – 24 VAC 1.0 Amp CSA Certified Class 2

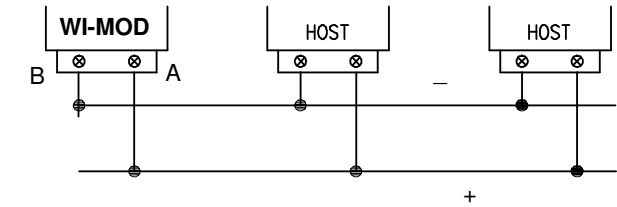
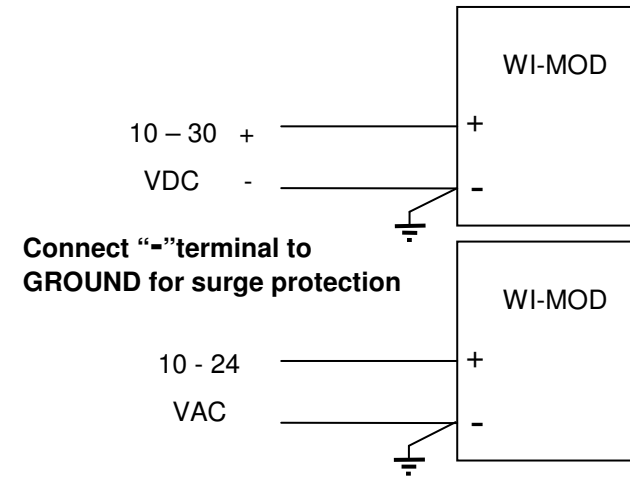

RS485 Connection

All connections to be SELV

CAUTION!

For continued protection against risk of fire, replace the internal module fuse only with the same type and rating

RS232 Connections

PC's

PLC's, Dataloggers

