

de **Sicherheitshinweise**

GEFAHR	
	Zur sicheren Installation und zum sicheren Betrieb des Gerätes ist Folgendes zu beachten: <ul style="list-style-type: none"> Das Gerät darf nur von qualifiziertem Fachpersonal montiert werden. Vor dem Abschluss des festen Einbaus darf am Gerät keine gefährliche Spannung angelegt werden. Bei Anwendungen, in denen gefährliche Spannungen an den Ein-/Ausgängen des Geräts angeschlossen sind, ist auf genügend Abstand bzw. Isolation von Leitungen, Anschlussklemmen und Gehäusen zur Umgebung (inkl. Nebengeräten) zu achten, um den Schutz vor elektrischem Schlag zu gewährleisten. Das Gerät muss von einer SELV-Quelle versorgt werden, gemäß der Niederspannungsrichtlinie 2014/35/EU und 2014/30/EU.
VORSICHT	
	Bei der Handhabung des Geräts sind die entsprechenden Schutzmaßnahmen gegen elektrostatische Entladung (ESD) zu beachten.

en **Safety notices**

DANGER	
	For safe installation and safe operation the following must be observed: <ul style="list-style-type: none"> The equipment may be installed only by qualified experts. Until the device is installed, do not connect hazardous voltages to the device. The device may only be operated in an environment with pollution degree 2 or lower acc. to IEC 60664-1. In applications where hazardous voltage is connected to in-/outputs of the device, sufficient spacing or isolation from wires, terminals and enclosure to surroundings (incl. neighbouring devices), must be ensured to maintain protection against electric shock. The device must be supplied by a SELV source as defined in the Low Voltage Directive 2014/35/EU and 2014/30/EU.
CAUTION	
	Appropriate safety measures against electrostatic discharge (ESD) must be considered when handling the devices.

fr **Consignes de sécurité**

DANGER	
	Afin que l'installation et le fonctionnement de l'appareil soient sécurisés, tenir compte de ce qui suit : <ul style="list-style-type: none"> L'appareil doit être monté exclusivement par un personnel qualifié. Avant de terminer le montage fixe, n'appliquer aucune tension dangereuse sur l'appareil. L'appareil ne doit fonctionner que dans un environnement présentant un degré de pollution de niveau 2 au maximum selon IEC/EN 60664-1. Dans les applications pour lesquelles des tensions dangereuses sont appliquées aux entrées/sorties de l'appareil, il faut veiller à garder une distance ou une isolation suffisante entre les câbles, bornes de connexion et boîtier par rapport à l'environnement (appareils voisins compris) afin de garantir la protection contre les chocs électriques. L'appareil doit être alimenté par une source SELV telle que définie dans la directive basse tension 2014/35/EU et 2014/30/EU.
ATTENTION	
	Lors de la manipulation des appareils, respecter les dispositions adéquates de protection contre les décharges électrostatiques (pointes de tension).

it **Indicazioni di sicurezza**

PERICOLO	
	Per un'installazione e un esercizio sicuri dell'apparecchio occorre attenersi a quanto segue: <ul style="list-style-type: none"> Il dispositivo può essere montato solo da personale tecnico qualificato. Non dare tensione elettrica pericolosa all'apparecchio prima della conclusione dell'installazione fissa. Il dispositivo può essere utilizzato solo in un ambiente che non supera una gravità di inquinamento 2 secondo la norma IEC/EN 60664-1. Per le applicazioni in cui vengono collegate tensioni pericolose agli ingressi/alle uscite dell'apparecchio, occorre mantenere una distanza di assicurare un isolamento sufficienti in relazione ai cavi, ai morsetti di collegamento e alle custodie rispetto all'ambiente circostante (compresi gli apparecchi accessori), al fine di garantire la protezione dalle scosse elettriche. Il dispositivo deve essere alimentato da una sorgente SELV come definito nella direttiva sulla bassa tensione 2014/35/EU e 2014/30/EU.
ATTENZIONE	
	Per la manipolazione degli apparecchi occorre attenersi alle misure di sicurezza in materia di prevenzione delle scariche elettriche (ESD).

es **Indicaciones de seguridad**

PELIGRO	
	Para una instalación y funcionamiento seguros del equipo debe tener presente lo siguiente: <ul style="list-style-type: none"> El dispositivo debe ser instalado exclusivamente por personal cualificado. Antes de finalizar el montaje fijo, el aparato no debe exponerse a tensiones peligrosas. El dispositivo debe utilizarse únicamente en un ambiente que no supere el grado de contaminación 2 según la norma IEC/EN 60664-1. En aplicaciones en las que hay tensiones peligrosas conectadas a las entradas/salidas del aparato, debe procurarse una distancia o aislamiento suficiente entre cables, bornes de conexión y carcasas y el entorno (incluidos aparatos secundarios) para asegurar la protección frente a posibles electrocuciones. El dispositivo debe ser alimentado por una fuente SELV tal y como se define en la Directiva de Baja Tensión 2014/35/EU y 2014/30/EU.
ATENCIÓN	
	Durante la manipulación de los aparatos deben observarse las medidas de protección frente a descarga electrostática correspondientes.

zh **安全规程**

危险	
	为保证安装和操作安全, 请务必遵守下列规程: <ul style="list-style-type: none"> 只允许有资质的专业人员安装设备。 在装置安装前, 切勿将危险电压接通至装置。 只允许在依据 IEC/EN 60664-1 有不超过 2 级污染等级的环境中运行设备。 在应用中, 装置的输入/输出如果要接入危险电压, 必须保证导线、端子和外壳与四周 (包括相邻的装置) 之间有充分的空间间隔或隔离, 以确保防触电保护有效。 设备必须由低电压指令 2014/35/EU 和 2014/30/EU 中定义的 SELV 电源供电。
注意	
	在对装置进行操作时, 必须注意对静电放电(ESD)采取适当的安全措施。

de Bedienungsanleitung
Industrial Security Router

en Operating instructions
Industrial Security Router

Weidmüller
Weidmüller Interface GmbH & Co. KG
Klingenbergstraße 26
32758 Detmold, Germany
T +49 5231 14-0
F +49 5231 14-292083
www.weidmueller.com

3060390000/03/03.2026

IE-SR-4GT-M 2990450000
IE-SR-4GT-LTE/4G-USEMEA-M 2990440000



Technische Daten / Technical Specifications

de	en	fr	it	es	zh	IE-SR-4GT-M 2990450000	IE-SR-4GT-LTE/4G-USEMEA-M 2990440000
Elektrische Daten	Electrical data	Caractéristiques électriques	Dati elettrici	Datos eléctricos	电气数据		
Eingangsspannung	Input voltage	Tension d'entrée	Tensione di ingresso	Tensión de entrada	输入电压	24 V DC (19.2 ~ 28.8 V DC), galvanically isolated	
Max. Leistungsaufnahme bei 24 V DC	Max. power consumption at 24 V DC	Consommation de puissance max. à 24 V DC	Potenza assorbita massima a 24 V CC	Consumo de potencia máx. a 24 V CC	24 伏直流电压下的最大功耗	1.3 A	1.5 A
Verpolungsschutz vorhanden	Reverse polarity protection present	Protection contre les inversions de polarité disponible	Protezione contro l'inversione di polarità presente	Protección contra polarización inversa disponible	有反极性保护		✓
Umgebungsbedingungen	Environmental conditions	Conditions ambiantes	Condizioni ambientali	Condiciones del entorno	环境条件		
Betriebstemperatur	Operating temperature	Température de fonctionnement	Temperatura d'esercizio	Temperatura de servicio	工作温度	-25 °C ... 70 °C	
Lagertemperatur	Storage temperature	Température de stockage	Temperatura di magazzino	Temperatura de almacenamiento	存储温度	-40 °C ... 85 °C	
Feuchtigkeit	Humidity	Humidité	Umidità	Humedad	湿度	5% ... 90%, no condensation	
Max. Einsatzhöhe ohne Derating¹	Max. altitude without derating¹	Hauteur d'utilisation max. sans déclasserment¹	Altezza di impiego massima senza derating¹	Altura máx. de funcionamiento sin derating¹	无降额的最大使用高度¹	2000 m	
Allgemeine Daten	General data	Données générales	Dati generali	Datos generales	常规数据		
Höhe x Breite x Tiefe	Height x Width x Depth	Hauteur x largeur x profondeur	Altezza x Larghezza x Profondità	Altura x anchura x profundidad	高度 x 宽度 x 深度	150 x 35 x 115 mm	
Gewicht	Weight	Poids	Peso	Peso	重量	752 g	
Verschmutzungsgrad	Pollution degree	Degré de pollution	Livello di inquinamento	Grado de polución	污染等级	2	
Schutzart	Protection class	Degré de protection	Classe di protezione	Tipo de protección	防护等级	IP20	
Anschlussdaten Stromversorgung	Connection data power supply	Alimentation des données de connexion	Collegamento alimentazione dati	Alimentación de datos de conexión	连接数据 电源		
Anzahl Anschlussstecker	Number of terminal blocks	Nombre de prises de raccordement	Numero di spine di collegamento	Número de clavijas de conexión	连接插头数量	1	
Leiterquerschnitt	Wire cross-section	Diamètre du câble	Sezione del conduttore	Sección del conductor	导体横截面	0.14 ... 1.5 mm² (AWG 16 ... AWG 26)	
Abisolierlänge	Insulation stripping length	Longueur de dénudage	Lunghezza di spellatura	Longitud de desaislado	剥皮长度	9 mm	
Anschlussdaten	Connection data	Données de connexion	Dati di collegamento	Datos de conexión	联接数据		
Digitale Eingänge	Digital inputs	Entrées numériques	Ingressi digitali	Entradas digitales	数字输入	4 x galvanically isolated Cut: physically disconnects (Link Down) the WAN port (24 V in) Trigger pre-configured packet filter rules (24 V in) VPN-initiate: establishes a pre-configured VPN connection (24 V in)	
Digitale Ausgänge	Digital outputs	Sorties numériques	Uscite digitali	Salidas digitales	数字输出	4 x VPN-active: indicates an active VPN connection (24 V out) Alarm: indicates a configurable network state or fault (24 V out)	
Schnittstellen	Interfaces	Interfaces	Interfacce	Interfaces	接口	4 x RJ45 port (10/100/1000BaseTX, auto negotiation, full-/halfduplex mode, Auto MDI/MDI-X port)	
USB-Schnittstelle	USB interface	Interface USB	Interfaccia USB	Interfaz USB	USB接口	1 x USB 2.0 (only for firmware update or restoration)	
Steckplätze für externe Antennen	External antenna slots	Emplacements pour antennes externes	Slot per antenne esterne	Ranuras para antenas externas	外置天线插槽	-	3
Steckplätze für SIM-Karten	SIM card slots	Emplacements pour cartes SIM	Slot per schede SIM	Ranuras para tarjetas SIM	SIM 卡插槽	-	2
SCM-Karten-Steckplätze	SCM card slots	Emplacements pour cartes SCM	Slot per schede SCM	Ranuras para tarjetas SCM	SCM 卡插槽	1 x Smart Card (ID-000 format)	
Technologie	Technology	Technologie	Tecnologia	Tecnología	技术		
Ethernet Standard	Ethernet standards	Ethernet standard	Standard Ethernet	Estándar Ethernet	标准以太网	IEEE 802.3 for 10Base-T IEEE 802.3u for 100Base-TX IEEE 802.3ab for 1000Base-T	
Normen	Standards	Normes	Norme	Normas	标准		
EMV	EMC	CEM	EMC	EMC	电磁兼容性	EN 61000-6-2 EN 61000-6-4	
Vibrationsfestigkeit	Vibration resistance	Tenue aux vibrations	Resistenza alle vibrazioni	Resistencia a las vibraciones	抗震动性	IEC 60068-2-6	
Schockfestigkeit	Shock resistance	Résistance aux chocs	Resistenza agli urti	Resistencia a choques	抗冲击性	IEC 60068-2-27	

Abmessungen / Dimensions

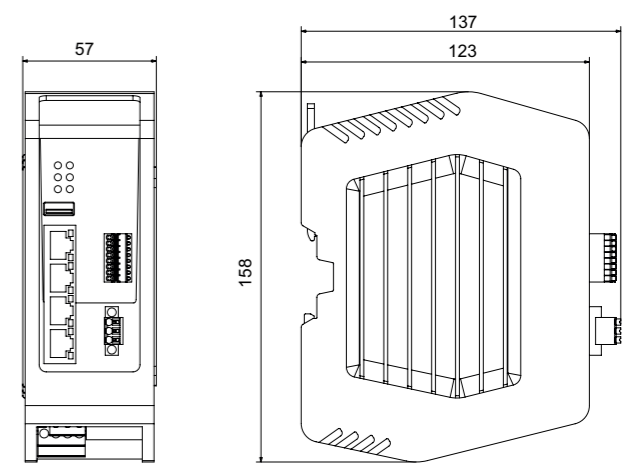

A Montage und Demontage / Mounting and demounting



Abb. / Fig. A1



Abb. / Fig. A2

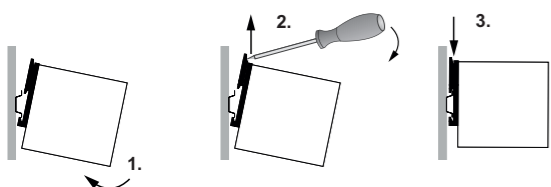

a / b / c
 Höhe / Breite / Tiefe
 Height / Width / Depth

B Anschlüsse / Connections

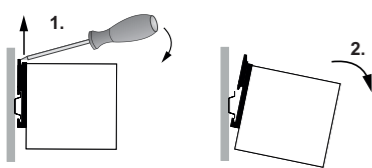
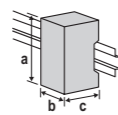
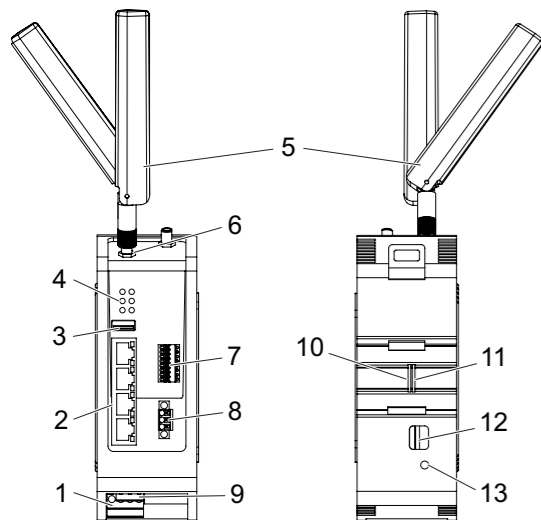

- 4-pin connector for I/O's
- RJ45 ports (10/100/1000Base-TX)
- USB port
- LEDs
- SMA male antenna – only IE-SR-4GT-LTE/4G-USEMEA-M
- 3 x SMA female screw connector for antenna (GNSS connector not in use)
- 8-pin connector for I/O's
- 3-pin connector for power supply
- 3-pin connector for RS485 interface
- Smart card / SIM card slot SIM2
- SIM card slot SIM1
- MicroSD card slot
- Reset button

C Anschlussbelegung / Connection diagram

8-pin connector for I/O's

Label	Function
V+	24 V DC
DI3	Digital input 3
DI4	Digital input 4
DI5	Digital input 5
DO3	Digital output 3
DO4	Digital output 4
DO5	Digital output 5
GND	Reference potential

4-pin connector for I/O's

Label	Function
V+	24 V DC
DI2	Digital input 2
DO2	Digital output 2
GND	Reference potential

3-pin connector for RS485 interface

Label	Function
GND	Reference potential
D-	Inverted data signal
D+	Non-inverted data signal

3-pin connector for power supply

Label	Function
V+	24 V DC
0V	Reference Potential
FE	Functional Earth

D LED Anzeige / LED indicator

PWR	green	Supply voltage OK
	flashing green (1 Hz)	Booting the device
	flashing green (5 Hz)	Processing firmware update
	off	No supply voltage
STAT	red	Error after boot process or recovering an image
	off	No supply voltage or no working firmware
VPN	off	VPN tunnel inactive
	green	VPN tunnel active
AP1	off / red / green	configurable
AP2	off / red / green	configurable
10/100/1000Base-TX Port	Upper LED	
	green	10/100/1000 Mbps link active
	off	10/100/1000 Mbps link inactive
	Lower LED	
	green	Data transmission at 1000 Mbps
	yellow	Data transmission at 100 Mbps
off	Data transmission at 10 Mbps	

Only LTE/4G models		
WWAN	green	Logged in, online
	flashing green	Connected to network provider Router activates connection on data flow (standby)
	yellow	Connected to network provider No activate data connection (offline)
	flashing yellow (1 Hz)	Searching wireless network
	flashing yellow (2 Hz)	Log-in declined
	flashing yellow (5 Hz)	Updating firmware of cellular module
off	4G/LTE connection inactive	

en

Intended use

The device is intended for setting up communication networks within an industrial environment, it is intended to be used in a restricted access location. The device may only be used within the scope of the specified technical data. Observing the documentation is part of the intended use.

The industrial router is equipped with 4 Ethernet ports, to operate in different networks. It features VPN support and firewall protection to ensure secure and efficient data transmission across the network. The model IE-SR-4GT-LTE/4G-USEMEA-M also supports wireless connectivity options for diverse industrial applications. In addition, digital inputs and outputs enable actions such as switching relays or controlling actuators. For example, alarms can be triggered, statuses monitored or processes automated.

For maritime applications applies: The router is a device with IP20 protection. Depending on the installation site, additional protection against salt spray must be ensured through installation in a suitable enclosure (e.g. control cabinet, control box, console or similar). The device may only operate on DC grids.



Assembly and installation may only be carried out by an electrician.



Additional documentation and firmware updates can be downloaded via the online catalogue.

Cyber security



Please observe the Weidmüller Industrial Cyber Security website. Please also observe the following documentation on the website:

- Industrial Product Security Guideline
- Security Data Sheet Router 4TX & 4GT models

Scope of delivery

- 1 x Industrial Security Router
- 1 x 4-pin connector for I/O's
- 1 x 8-pin connector for I/O's
- 1 x 3-pin connector for power supply
- 1 x 3-pin connector for RS485 interface
- 1 x cover for pins
- 1 x Hardware Installation Guide
- 2 x SMA male antenna – only IE-SR-4GT-LTE/4G-USEMEA-M

Mounting the device

WARNING



Dangerous contact voltage!

- Carry out mounting and wiring work only when the power supply is disconnected.
- Make sure that the place of installation (switch cabinet etc.) has been disconnected from the power supply.

- Clip the device on to a 35 mm DIN mounting rail, e.g. Weidmüller TS 35x7.5, see Fig. A1.

Installing the device

NOTICE

Material damage!

- The supply voltage may not be greater than the voltage indicated on the product label.
- Check the voltage of your power source to make sure you are using the correct voltage.



The power supply input is galvanically isolated.

- Connect the device to a 24 V DC power supply with the included 4-pin connector, see Fig. C.

Once the power supply is connected to the device, the PWR LED starts flashing green. If the PWR LED is lit the router is ready to run.

I/O interfaces

Enables additional monitoring and alarming, see Fig. C.



There is no DO1 and DI1 for manufacturing reasons.

RS-485 (EIA-485) interface

The fieldbus node is galvanically isolated from power supply. Its unit load is 1/8, see Fig. C.

Connecting RJ45 Ethernet

The configuration of the device has to be done via web browser. The initial configuration can be done via LAN or WAN interface of the router. For the connection both, a standard or a crossover Ethernet cable can be used. By default, each Ethernet interface is set to autocrossing / autonegotiation.

Smart cards

The Smart card is dedicated for the backup of configuration files.



Only Smart cards in format ID-000 according to ISO 7816 (25 x 15 mm) can be used.

- Insert the Smart card into slot 9 SIM2 at the rear side of the device, see Fig. B.

Devices with cellular modems

For router model IE-SR-4GT-LTE/4G-USEMEA-M the antennas and the SIM card should be used as follows:

- Connect the included or external antenna to the connectors on top of the housing 8, see Fig. B.



Only SIM cards in format ID-000 according to ISO 7816 (25 x 15 mm) can be used.

- Insert the SIM card into slot 9 or 10 SIM2/SIM1 at the rear side of the device, see Fig. B.

Commissioning the device

Before commissioning the device for the first time, we strongly recommend checking the installed firmware version and updating to the latest version, if a newer one is available. Please check and download the newest version from the Weidmüller website.

Configuring via web browser



With factory settings generally, the device can be configured on both Ethernet interfaces (LAN and WAN) if the IP address of the connected port is known. Please note that the IP address of the configuration PC has to be in the same IP address range as the connected router port.

Factory default settings

Language Web interface: English
 Operating mode: IP router

Default IP addresses

ETH2-4 port: 192.168.1.110 (static value)
 Subnet mask: 255.255.255.0
 ETH1 port: DHCP

Configuration of PC network interface

- Configure the PC's network IP address and subnet mask according to the IP address range of the connected router port.

Example for connection PC - Router-ETH2-4-Port:

IP address PC: 192.168.1.99
 Subnet mask: 255.255.255.0

Connecting to the web interface

- Open your web browser and enter the IP address of the connected router port into the browser's address line.

<http://192.168.1.110> (if connected to a ETH2-4 port)

- After the appearance of prompt (login), enter the following login values (factory settings):

User name: admin
 Password: Detmold

- Click **OK** to confirm.

The home page of the router will be displayed.

Resetting to factory settings

- The device can be reset at any time.
- Disconnect the power from the router.
- Press and hold the **Factory Default** button while reconnecting the router and keep the button pressed until the booting process is complete.

The status LED turns on briefly, then all LEDs turn off until the Power LED starts flashing slowly (1 Hz). After the booting process is complete, the Power LED starts flashing fast (10 Hz).

- Release the **Factory Default** button and wait until the Power LED lights permanently green.

The router is reset to factory settings and available again.

LED indicators

LEDs indicating the status and Ethernet connection are placed on the front of the device, see Fig. B. The LED behaviour is described in Fig. D.

Disassembly

- Remove all cables and lines.
- Remove the device from the DIN rail, see Fig. A2.

Disposal



Observe the notes for proper disposal of the product. You can find the notes here: www.weidmuller.com/disposal.

